

FSU NUCLEAR LAB MANUAL

Updated:

May 27, 2016

Contents

1	Help Call List for Evenings, Weekends, Holidays	5
2	Water Cooling System	10
3	Tandem/SNICS Power Failure Procedures	10
4	CryoPump Regeneration Procedure	12
5	Cable Changes for Switching Ion Source	13
6	SNICS Source Operation	14
7	Tuning Beam out of the SNICS Source	14
8	Typical Cathode Behavior	17
9	SNICS Temporary Turn Down	17
10	SNICS Turn Down to Idle Mode	18
11	SNICS Cathode Change Instructions	19
12	Outgassing a New Ionizer	21
13	Ion Source Shutdown and Disassembly	22
14	RF Source Operation	24
	14.1 Operating Principle	24
	14.2 RF Discharge Contaminants	24
	14.3 Summary of Operation	25
15	RF Source Tuning Instructions with the PC	27
	15.1 Focusing and Steering Control	27
	15.2 Optimizing on Source Cup-2	27
16	Hardware/Cable Changes for Switching Target Rooms	28
	16.1 From the Tandem Target Room to the LINAC Target Room	28
	16.2 From LINAC Target Room to Tandem Target Room	29
17	Hardware/Cable Changes for Choosing a BeamLine out of the Switching Magnets	30
	17.1 LINAC Target Room Switching Magnet	30
	17.2 Tandem Target Room Switching Magnet	31
18	Tandem Beamline SF₆ Gas Security Ball Valves	32

19 Tandem Beamline Vacuum Protection System	32
20 Tandem Pelletron Interlock Panel	33
21 Terminal Potential Stabilizer	35
22 Operating Instructions for the Tandem Pelletron	36
22.1 To Turn the Tandem Pelletron On	36
22.2 To TURN OFF the Tandem Pelletron	38
22.3 To Change the Terminal Potential	38
23 Extended Tandem Pelletron Shutdown	39
24 Terminal Stripper Foil Changer	40
25 Terminal Foil Band Changer	41
26 Letting the Accelerator Tubes Up to Dry Nitrogen	42
27 Pumping Down the Accelerator Tubes	43
28 Tandem Pressure Vessel Sulfur Hex Alarm Circuit Description	45
29 Voltage Conditioning the Tandem	46
30 Worthington Compressor	47
31 Emergency Valve Closures	48
32 Equalizing the SF₆ Gas to the Outside Storage Vessel	49
33 Compressing the SF₆ to the Storage Vessel	50
34 Vacuum Pump Boosting for the Compressor	51
35 Shutoff Procedure	52
36 Venting the Tandem to Air	52
37 Removing Air from the Tandem	53
38 Equalizing SF₆ into the Tandem	54
39 Compressing SF₆ into the Tandem	54

40 Adding SF₆ to the Inventory from Cylinder	56
40.1 Adding SF ₆ directly to the Tandem From Cylinders	56
40.2 Removing the SF ₆ remaining in the cylinders at Tandem pressure	56
41 SF₆ Gas Drying	58
42 SF₆ Leak Checking Gun	59
43 LINAC Operating Instructions	65
43.1 Power Outage Procedure	65
43.2 Restart Procedure	65
43.3 Troubleshooting Linac out of Lock Problems	67
43.3.1 Troubleshooting Loss of Beam Phase Lock	67
43.3.2 Resonator Lock Status	73
43.4 The Linac Energy/Timing Chamber	78
43.4.1 Background	78
43.4.2 Insertion of Target into Beam	78
43.4.3 Measuring the Beam Energy	79
43.4.4 Measuring the Time Spectrum of the Beam from the Tandem	79
43.5 Instructions for setting Superconducting Linac Solenoids	80
43.6 Workhorse-Resonator Calibration Procedures	81
43.7 Memorandum: February 22, 1991	83
43.8 Memorandum: July 27, 1987	85

1 Help Call List for Evenings, Weekends, Holidays

Situations arise out of normal staff working hours that require attention by staff personnel. Due to the limited time available to visiting outside user groups and their unfamiliarity with the laboratory equipment the staff is more than willing to concede their personal time to ensure the acquisition of data by these groups. Out of consideration to staff members and their families it is necessary to assess the situation and determine whether or not a call to a staff member's home is warranted. In-house users should not expect the staff to come into the lab outside of normal hours unless extenuating circumstances are deemed acceptable by more than the currently stalled experimental group. Please use the following as a guide when considering calling the staff at home. For a general layout of the lab, the ground floor of NRB building, and the Tandem vault, see Figures 1, 2, and 3 respectively.

O.K. to Call:

Failure of equipment that could create a potentially dangerous situation to lab personnel and experimenters or that may result in extended down time for the accelerators. Examples of these types of failures might concern compressed air service, SF₆ leaks, cryostat vacuum integrity, cryogenic fluid spills/leaks, Helium liquefier failures, cooling water interruptions, power outage, electrical failures, mechanical or structural failures. Abnormal behavior by equipment that suggest failure is imminent unless someone intervenes should also be considered - especially potentially expensive failures that can be avoided if they are quickly rectified.

Not O.K. to Call

These problems are typically due to an inability to take data. Data acquisition problems may be due to Ion Sources, Tandem, Linac or computers. In-house users are expected to familiarize themselves with the equipment so that they can diagnose and rectify the more common problems such as resonators out of lock, cryopump regeneration, ion source adjustment, stripper foil fatigue, etc. The staff is dedicated to ensuring the facility's ability to produce data for the experimental groups and often a quick phone call can enable the experiment to resume; however, consider the time of day and the complexity of the fault before picking up the phone.

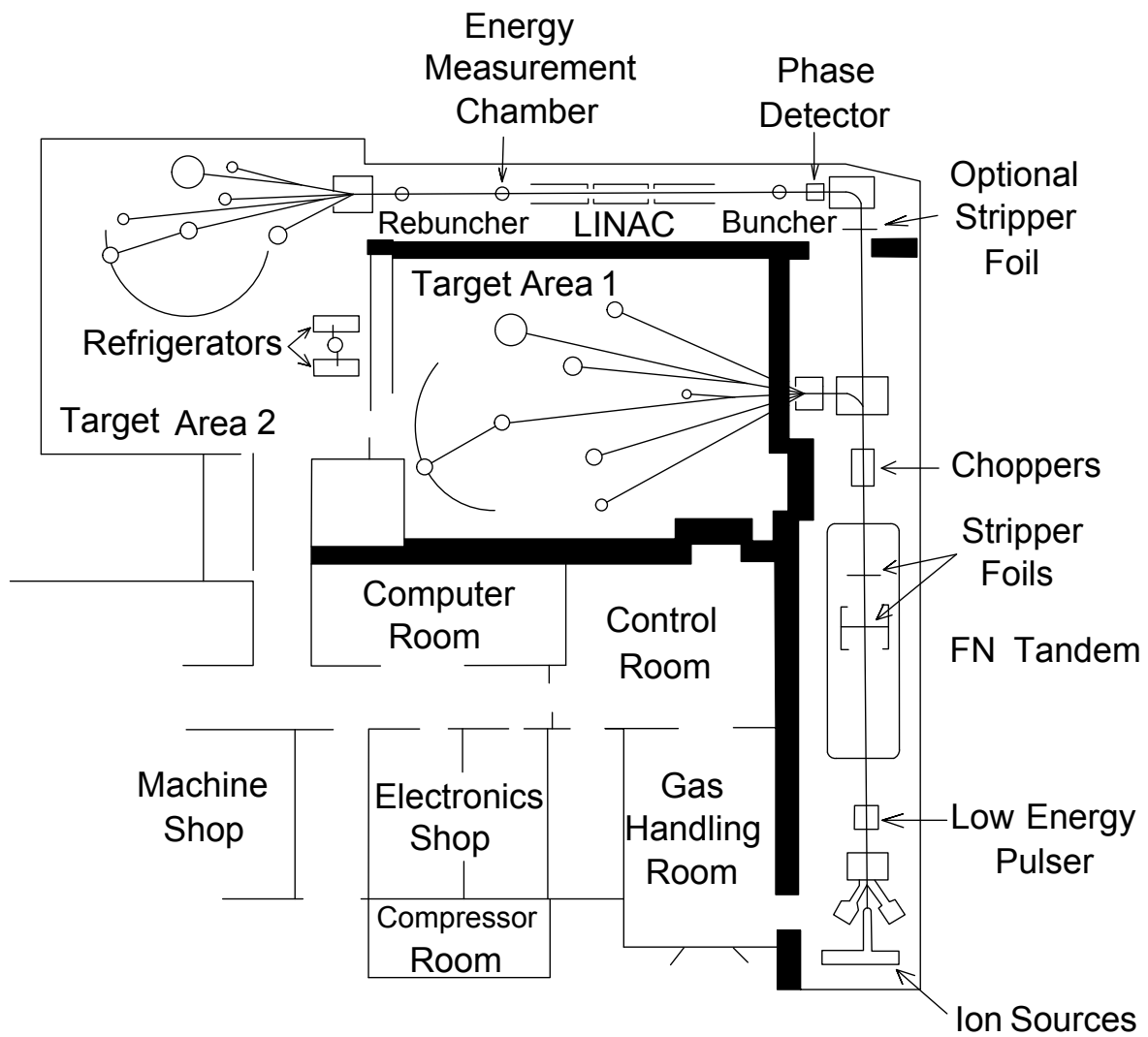

General layout of F.S.U. heavy ion accelerator laboratory

Figure 1: Lab Layout

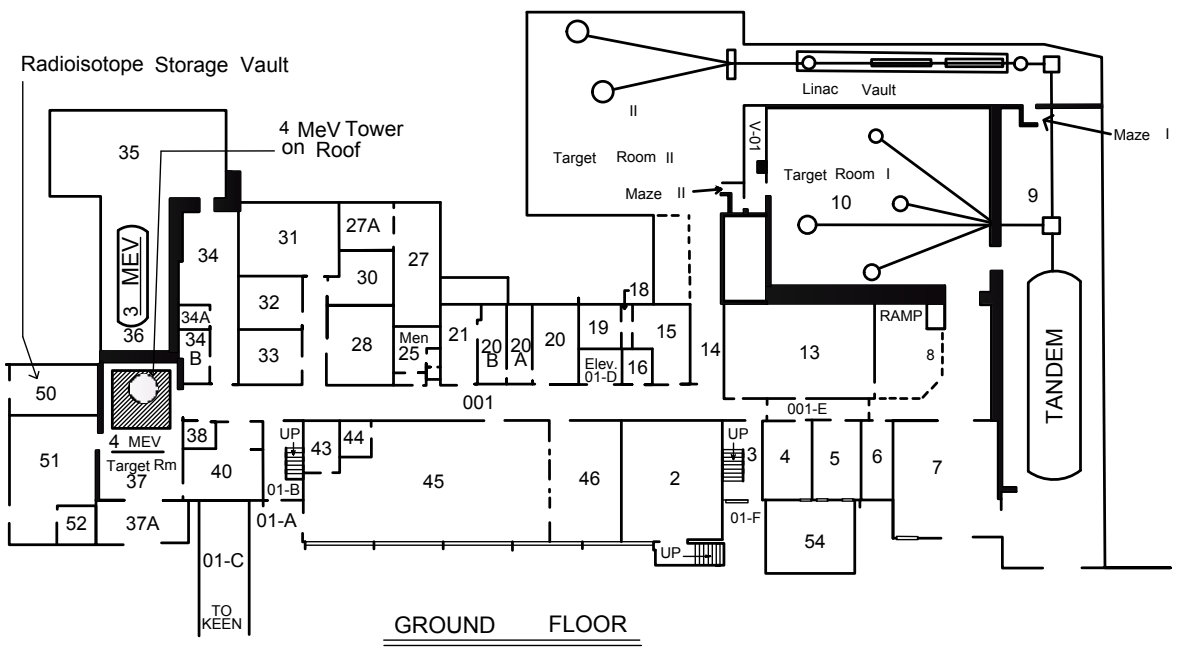

Figure 2: Ground Floor

Tandem Vault Locator Map

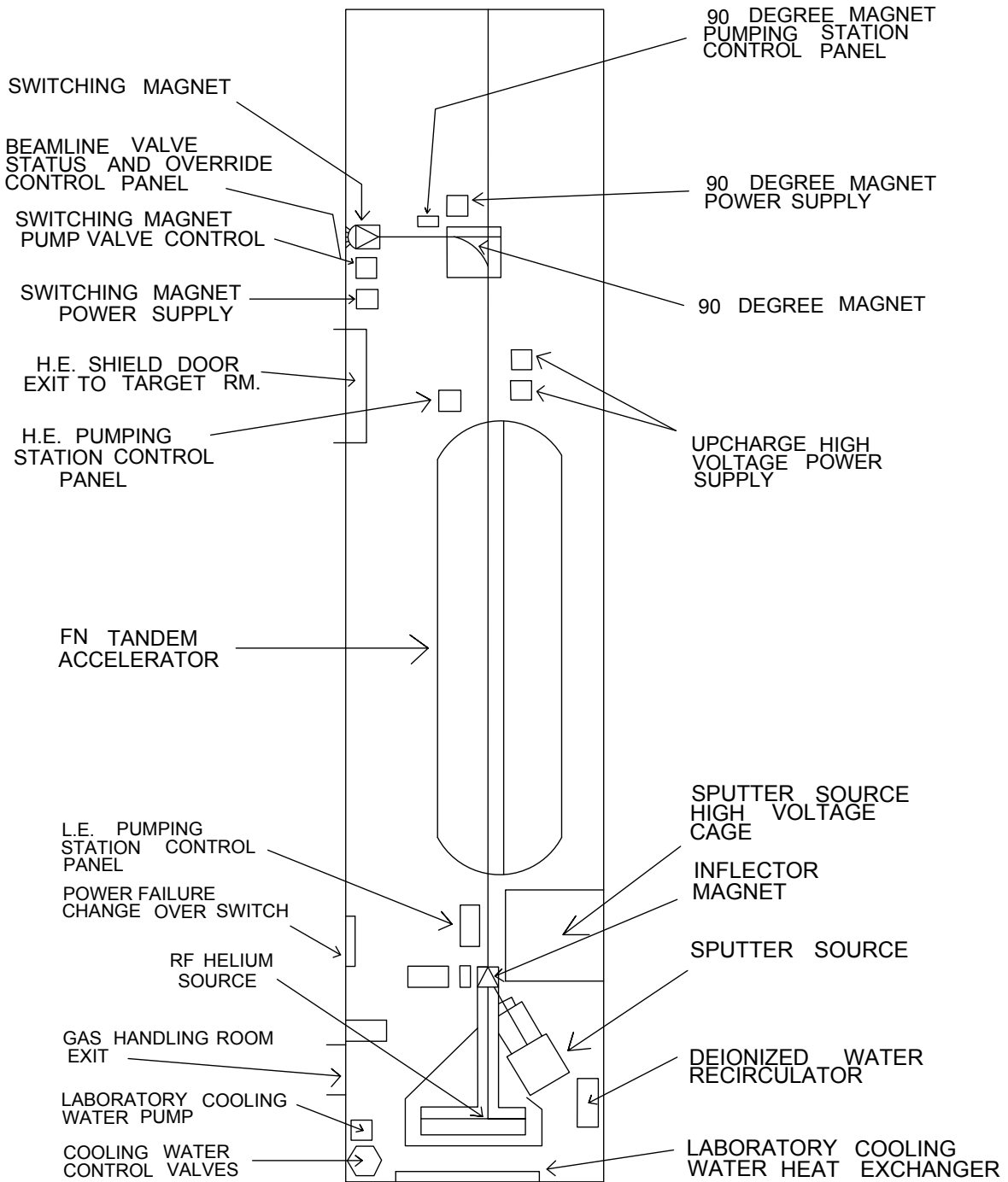

Figure 3: Tandem Vault

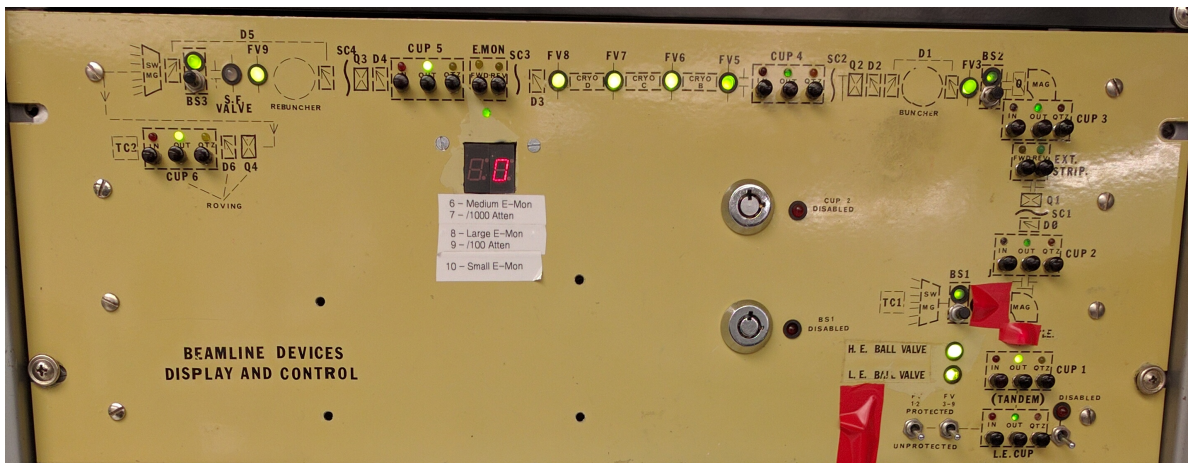

Figure 4: Beamline Devices Panel for Cup Reference

2 Water Cooling System

The recirculating cooling water in the lab employs a heat exchanger, temperature controlled valve, filter and pump to provide cold water service to equipment. Bending magnets, PIN Diode Pulsars, Sputter Source (SNICS), Tandem are some of the equipment that require cooling to remain in operation. The recirculating loop is automatically topped off by city or chilled water depending on availability. Should there be an interruption of water service to the building the following instructions apply. The valves are located in the Southeast corner of the Tandem Vault.

When Chilled Water Service is Interrupted:

Open the two valves labeled “city water” and close the two valves labeled “chilled water”. This changes the heat exchanger over to city water in for cooling the recirculating loop and then out to a drain. Change the recirculating water top off valve to the position labeled “city”.

When Chilled Water Service Returns:

Open the two valves labeled “chilled water” and close the two valves labeled “city water”. This changes the heat exchanger back to chilled water for cooling the recirculating loop.

Recirculator Pump Goes Off and Will Not Restart:

The recirculating loop can be fed directly by city water in an emergency situation. The valves C1 and D1 are located in the Southeast corner of the Tandem Vault. The valves C2, D2 and D3 are located in the Gas Handling Room (see figure 5). C2 and D3 are located by the L.E. vault entrance and D2 is located near the floor at the middle of the East wall. To bypass the recirculating loops water pump first ensure its power switch, positioned on the wall over the pump, is turned off. Close the valves C1 and C2. Open valve D1 and D2 first and then open D3. When the recirculator pump is operational again it should be placed back into service. Close valve D3 first and the close D1 and D2. Open valves C1 and C2. Now turn the recirculating pump back on. The system should now be providing cool water via the heat exchanger.

3 Tandem/SNICS Power Failure Procedures

When the mains fail the emergency generator should start automatically. If the emergency lights come on, the generator is running correctly. The changeover breaker should switch automatically and restore power to all pump circuits. If this does not occur, the change over breaker, located on the West wall of the accelerator vault between the L.E. door and the sink, should be assisted with a 2-by-4. Note: In the emergency power

General location of valves in the Gas Handling Room

Valves shown: 2, 4, 5, 6, 13, 20, 21, 29, 35, 36,
37, 38, 39, 40, 41, 43, 44, 46, 47, X-3

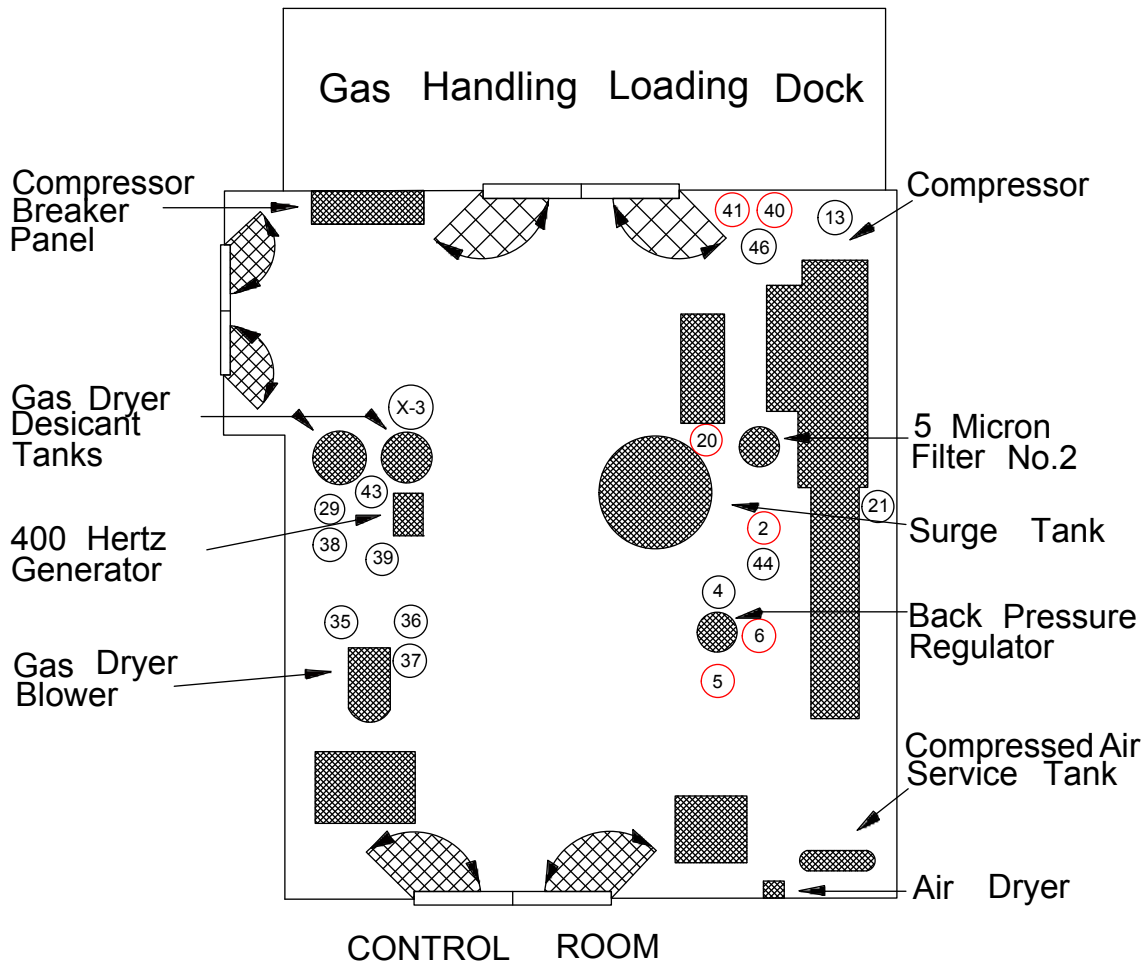

Figure 5: Gas Handling Room

position the central arm should be down.

When emergency power is available at the pumping stations a number of things should be checked:

1. Check that the recirculating pump, located just to the South of the L.E. door in the accelerator vault, is running. Restart if necessary. See water cooling system section in this lab guide 2.
2. Check that source pumping stations are operating normally. Restart pumps and reopen valves as necessary.
3. Check the turbo pump at the H.E. end, it may have tripped and be coasting down. It should be restarted.
4. Check cryopumps. If the supply was only interrupted for a few seconds the compressors will restart automatically, but the input and output pressures will remain the same for approximately one minute; then the unit will switch and normal pressures will be reestablished. When this occurs the coldhead will restart and the vibration of this motion will be felt at the cold head. If the power is off long enough for the pump to start to warn and outgas, it will have to be started again. See the section 4 for cryopump head regeneration.
5. The pumps in the target room should be checked to ensure that they are running normally. Restart or close off as necessary.

When mains voltage is restored the changeover breaker will wait a short time, to ensure that the supply will probably remain on, and then will automatically change over and the emergency generator will shutdown. If the breaker hangs up it can be assisted up with the 2-by-4. When the mains supply has been restored to the pumping stations the previous checks should be repeated. When all vacuums are normal the beamline valves should be checked and reopened as necessary. Make sure that the vacuum is good on both sides before opening any valve.

4 CryoPump Regeneration Procedure

A cryopump is a capture pump and requires regeneration when capacity is reached. Indications of the pump having reached capacity include a loss of pumping speed and a warming of the 22 Kelvin cryopanel. To regenerate the cold head:

1. Isolate the pump from the vacuum chamber; usually, a gate valve is used. Ensure that the valve control is in protected mode if there is an interlock system in use.
2. Turn off cold head power. If a portable compressor is used, this should be turned off as well. CTI systems have separate switches for the compressor and cold head, while APD has only a single switch. In target room 2, the coldheads are powered with a homemade box.

3. Obtain a source of dry Nitrogen. For example, at the low energy end of the Tandem, there is a 1/4" nylon tube with a rubber stopper available. Nitrogen for the 90° magnet and switching magnet cryopumps can be obtained from a similar tube located directly between the quadrupoles at the high energy end of the Tandem. In target room 2, you are on your own; however, bottled nitrogen is available.
4. Purge the pump with nitrogen by inserting the stopper into the roughing port and opening the roughing valve. Allow the nitrogen to flow through the pump and out the relief valve. Allow the pump to purge for about 30 minutes.
5. Obtain and install a heat tape around the pump. Start the heat tape when the purge is started.
6. Allow the pump's internal cryopanel to reach ambient temperature. This should take at least 2 hours. If time is not critical, allow 4 to 6 hours for warm up.
7. After warm up is complete, purge the pump with nitrogen for a few minutes to remove any evolved gases that may still be in the pump.
8. Using an *oil free* roughing system, rough out the cryopump. Best performance is observed when a good rough vacuum is obtained. Pumping should continue for at least 20 minutes and until the following criteria are met:
 - (a) The cryopump reaches a minimum pressure and holds there for at least 10 minutes.
 - (b) A rate of rise test of the cryopump vacuum chamber indicates $dp/dt < 10$ milliTorr/min.
9. With the roughing port and gate valve both shut, restart the cryopump (cold head and compressor, if used). The first indication of a successful regeneration will be a reduction in pressure in the cryopump. Allow the cold head to operate until the temperature gauge indicates that the cryopanel is less than 20 Kelvin. Keep a log of time and temperature. Record entries at least every half hour. The cryopump should get cold within three hours.
10. If the regeneration is successful, open the gate valve. Observe the vacuum on the nearest penning gauge. Verify that the vacuum in the chamber improves, or at a minimum, does not rise.
11. If the regeneration is not successful, call Powell Barber at 644-6477.

5 Cable Changes for Switching Ion Source

Ensure all appropriate supplies are off!

1. Turn off the Preaccelerator H.V. Supply Panel in the Control Room.
2. Run the Inflector Magnet current to zero.
3. Flip the sign for designating which source is in use on the Preaccelerator H.V. Supply Panel.
4. Exchange the H.V. lead for the appropriate source at the supply in the Tandem Vault. Be wary of the lead; some voltage may still be present.
5. Change the knife switch position located in the gray box at the Switching Magnet in the Tandem Vault to the position for the desired ion source.
6. Flip the switch located on the back of the Preaccelerator H.V. Supply Panel in the Control Room for the interlock circuit for the ion source required.
7. Inspect the slits after the Inflector Magnet for the appropriate setting (0.100”).

6 SNICS Source Operation

(See figures 6 and 7)

The Source of Negative Ions by Cesium Sputtering (SNICS) produces a negative ion beam. A reservoir of cesium metal is heated so that cesium vapor is formed. This cesium vapor comes from the cesium oven into an enclosed area between the cooled cathode and the heated ionizing surface. Some cesium condenses onto the cool surface of the cathode and some of the cesium is ionized by the hot surface. The positively charged ionized cesium accelerates towards the cathode, sputtering material from the cathode at impact. Some materials will preferentially sputter neutral or positive particles which pick up electrons as they pass through the condensed cesium layer on the surface of the cathode, producing the negatively charged beam.

7 Tuning Beam out of the SNICS Source

These instructions assume the correct cathode is installed and the necessary hardware/cable changes for selecting an ion source has been made. Also assumed is that the source has been turned down after a previous run but not necessarily to the idle mode. **Do not inject more than 10 microamperes of beam into the accelerator under any circumstances.**

1. Open the source exit valve in the Tandem Vault.
2. Insert the L.E. faraday cup and depress the corresponding push button on the integrator panel. Select the most sensitive scale on the integrator initially and then adjust the scale if and when the beam current pegs the meter.
3. In the Control Room, turn the ion source deflectors to zero.

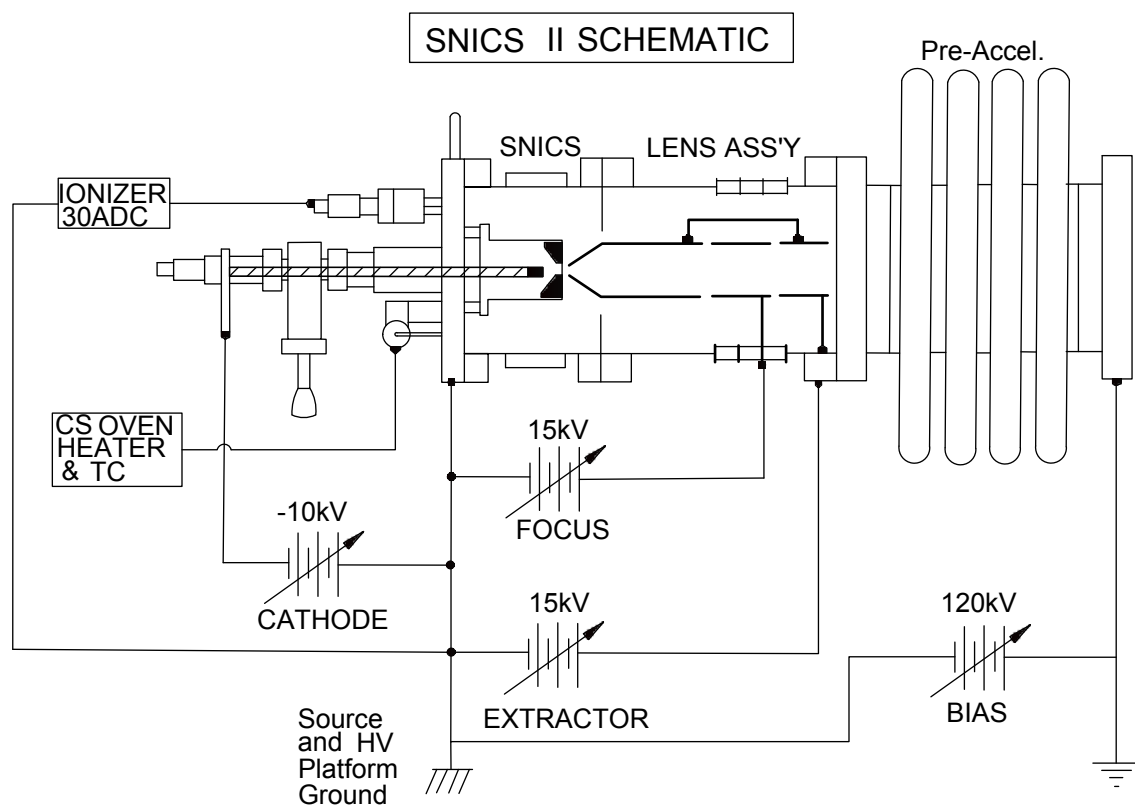

Figure 6: SNICS Schematic

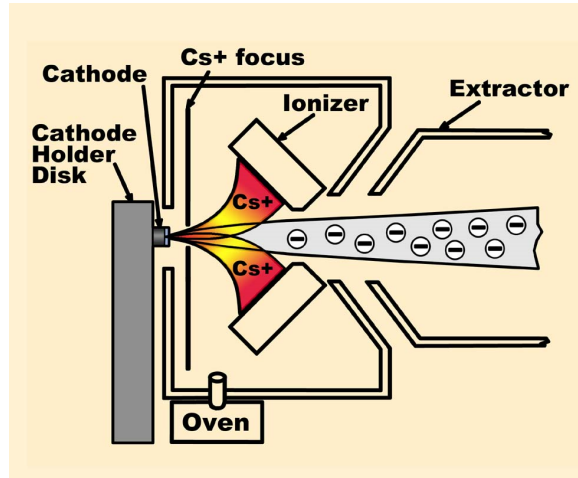

Figure 7: SNICS Source Diagram

4. Turn on and bring up the Preaccelerator High Voltage Supply to 120 KV.
5. Adjust the inflector magnet supply to indicate the predicted setting for the negative ion that is to be injected into the Tandem. A table is provided on the inflector control panel.
6. If the beam has been run before and the source parameters are known, adjust the SNICS Cathode and Extractor supplies to those values at the High Voltage Cage out in the Tandem Vault. If the Ionizer heater is to be adjusted do it in 4 ampere steps separated by 4 minute intervals.
7. If no parameters have been recorded or cannot be found set the SNICS Cathode and Extractor supplies to 7.5 KV.
8. Beam should be present on the L.E. cup; if not, adjust the inflector magnet slightly and attempt to find and maximize beam current. The inflector magnet should not be more than 0.15 units off of the predicted setting.
9. An iterative approach is used to maximize beam on the L.E. cup. After the magnet is fine tuned, adjust the SNICS Cathode and Extractor supplies in the Tandem Vault to maximize beam current. When satisfied, again adjust the inflector magnet in the Control Room and then the source H.V. supplies again. After this second round of tuning use the source deflectors in the Control Room to increase beam current on the L.E. cup. More rounds of adjustments should be attempted; however, maximum beam transmission through the Tandem does not occur at the same settings as those for maximum L.E. faraday cup beam current. Mostly the source deflectors and the inflector magnet require slight readjustment when tuning through the Tandem.

10. Assuming all the focusing and deflector elements are maximized for beam current, one can only adjust the Ionizer heater and the boiler temperature to attain more beam from the source. First increase the Ionizer heater current to increase the beam current; do not exceed 290 watts or premature failure of the heater will occur. If there is still insufficient beam current, increase the cesium boiler temperature in 100° steps separated by 45 minute intervals. Do not exceed 490° or the cesium vapor will cause internal arcing in the source. If there is too much beam, reduce the boiler temperature and monitor the beam current. If less beam is still desired reduce the Ionizer heater current in one ampere steps until the desired current is reached. The beam is ready for injection.
11. Should one not have success with tuning the desired beam, reducing the ion source deflectors to 50% of the optimum for a couple of iterations of source voltages and inflector magnet adjustments might be a useful approach. Ultimately, the deflectors should be adjusted to give the maximum beam on target.

8 Typical Cathode Behavior

Most often the material packed into the SNICS cathodes is either a solid or powder. In general new, unused cathodes are often found to require more time to reach the output level of cathodes that have seen previous use. The nature of the material and how it was stored, particularly if it is a hygroscopic or deliquescent, can be of paramount importance when investigating a low negative ion output. Most powdered cathodes are pressed here in the lab and are inherently “gassy” due to voids in the pressed material. The solid material cathodes are the preferred cathode whenever possible. To reduce “damage” to the cathodes while they are not in use it is imperative that the cathodes be wrapped tightly in aluminum foil and placed in a tightly capped bottle that has been back filled with argon.

Solid cathodes when initially inserted into the source, assuming it is suitable material (ice cubes don’t work well), will outgas in a very short period of time. Beam from the ion source can typically be had in sufficient quantity in the time it takes the ionizer and boiler temperatures to be brought to the typical operating values.

Powder cathodes work best when they are pressed with dry powder and stored in a dry environment. These cathodes will take longer to outgas than their solid counterparts and the ion source extractor and cathode voltages will often suffer stability problems. Previously used cathodes, especially depending on the nature of the material, can sometimes take up to half a day to behave in a stable fashion and produce the desired beam current.

9 SNICS Temporary Turn Down

When a break or interruption occurs during the process of data collection and the use of the negative ion source will not be required by the experimental group for four or

more hours it is desirable to turn down the source to prolong its operational life time.

1. Turn down and off the preaccelerator high voltage supply in the Control Room.
2. In the Tandem Vault, close the source exit valve.
3. Reduce the Cesium Boiler Heater to zero on the variac scale by turning the control rod located at the high voltage cage.
4. Reduce the ionizer heater current in four ampere steps separated by two minute intervals to fifteen amperes by turning the control rod attached to the ionizer power supply located at the high voltage cage.
5. Note in the Tandem Log Book, located in the Control Room, the time the source was turned down to the idle mode.

10 SNICS Turn Down to Idle Mode

When the use of the negative ion source is no longer required by the experimental group it is desirable to leave the source in a state to prolong its operational life time: idle mode.

1. Turn down and off the preaccelerator high voltage supply in the Control Room.
2. Turn down and off the source deflectors in the Control Room.
3. Turn the inflector magnet supply completely down.
4. In the Tandem Vault, close the source exit valve.
5. Reduce the Cesium Boiler Heater to zero on the variac scale by turning the control rod located at the high voltage cage.
6. Reduce the ionizer heater current in four ampere steps separated by two minute intervals to fifteen amperes by turning the control rod attached to the ionizer power supply located at the high voltage cage.
7. Turn the Lens, Extractor and Cathode H.V. supplies to zero with the control rod extending from the H.V. cage.
8. Note in the Tandem Log Book, located in the Control Room, the time the source was turned down to the idle mode.

11 SNICS Cathode Change Instructions

Before beginning the cathode change procedure ensure the current settings for the source parameters are recorded in the Cathode Utilization Log hanging on the Source H.V. Cage. This procedure assumes the SNICS (Source of Negative Ions by Cesium Sputtering) is in operation. The cage surrounding the SNICS source is referred to as the “Source H.V. cage” and the cage surrounding the power supplies as simply the “H.V. cage”.

1. In the Control Room, turn down the Preaccelerator H.V. supply and then turn the power off.
2. In the Tandem Vault source area, close the source exit valve; observe that the H.V. warning beacon is not rotating.
3. Reduce the ionizer heater current in four ampere steps separated by intervals of two minutes until fifteen amperes is reached. This can be accomplished by turning the supply control rod sticking through the H.V. cage door; heater current is indicated by the supply. Also, turn down the extractor voltage and cathode voltage supplies by turning the appropriate control rods at the cage door; output voltages are indicated by the supplies.
4. At the source vacuum control panel are two toggle switches that must be placed in the “unprot” position; this is to prevent the isolation transformer from shutting off supplies due to a vacuum excursion in the source. Note the current vacuum indication at the backing line thermocouple controller on the source vacuum panel. Depress the red push button next to the baffle switch while making the change.
5. Open the source H.V. cage by releasing the two latches located at the right edge of the door: pull on the latch handle until it rotates 90 degrees towards you and then turn the latch handle until it clears the fixed cage frame. The cage door is a bifold type and should be opened by pushing it to the left.
6. Investigate the H.V. cage to ensure the ionizer heater supply and the Cesium feed line, indicated by a lit power switch, have not been interrupted.
7. Using the shorting rod that is hanging on the cage at the stainless steel U-bolt, touch the source on each side of the endmost ceramic insulator to reference the stainless steel (stainless steel) elements to ground. Hang the shorting rod between the air lock VAT valve and the HPS vacuum fitting clamp. * BE WARY OF THE WHITE IONIZER HEATER LEADS AND THE BOILER FEED TUBE AS THEY ARE LIVE *
8. Remove the H.V. cathode lead from the stop clamp (aluminum bar) attached to the cathode stainless steel coolant tube.

9. Ensure the compression fitting sealing the cathode assembly is only finger tight and then withdraw the assembly slowly and carefully. At 5 3/4" of travel a scribed line on the stainless steel tubing will emerge from the compression fitting. At 1/4" later a second scribed line will emerge indicating that clearance has been afforded the VAT air lock valve and it can be closed. To close the valve rotate the black handle clockwise (up and to the right) until it comes to a stop.
10. The green knob on the Nupro valve can now be opened to let the cathode air lock region up to atmospheric pressure.
11. Use one hand to withdraw the probe assembly (cooling lines still attached) until it is free from the source. With a glove on the other hand remove (unscrew) the old cathode and replace it with the new one.
12. Install the cathode assembly back into the compression fitting; loosen the fitting if necessary to get the probe started and then tighten it finger tight again. Slide the assembly in until the first scribed line is even with the compression fitting.
13. A nylon roughing line with a stainless steel tube fitted to its end should be at the source bottom cage grating, ensure its free of debris and insert it into the Nupro valves compression fitting. Snug the fitting on the tube and ensure the valve is still open.
14. At the source vacuum control panel, shut the backing valve by putting its toggle switch in the manual close position.
15. On the backing line of the source diffusion pump is a right angle, 1/4" brass valve with a black toggle handle, open this valve to allow the cathode air lock region to be roughed out. The vacuum can be monitored at the backing line thermocouple controller on the source vacuum panel. When the vacuum has reached the reading previously noted (about 10 microns) close the green handled Nupro valve and then the brass valve on the backing line.
16. Vacuum permitting, open the backing line valve with the toggle switch at the source vacuum control panel and place the two toggle switches in step 4 back to the "prot" position. Depress the red push button next to the baffle switch while making the change.
17. Remove the nylon roughing line from the Nupro valve and place it back at the bottom cage grating.
18. While watching the sputter source penning gauge, open the VAT air lock valve by rotating the black handle counter clockwise (up and to the left) until it comes to a stop. A temporary degradation of the vacuum should be indicated by the penning gauge. If the vacuum does not show signs of recovering in 10 seconds close the air lock valve and determine the source of the gas load. Outgassing of the cathode is

not uncommon and is indicated by a vacuum that quickly recovers but not to the level previous to the air lock valve being opened. The vacuum will slowly improve and attain the expected base vacuum of about 1×10^{-7} torr.)

19. Carefully slide the cathode assembly into the source until the aluminum stop clamp on the assembly is flush with the compression fitting. There may be an premature stop encountered before the stop clamp is flush with the compression fitting, if so, slightly wiggle the cathode assembly until it is free to be fully installed. Ensure the compression fitting is snug when the installation is complete.
20. Reconnect the clear lead for the cathode H.V. supply back to the stop clamp.
21. Remove the shorting rod from the source and hang it back on the cage at the stainless steel U-bolt. Close the cage door and remake the latches.
22. Inspect the H.V. cage to ensure the extractor and lens supplies are again energized. The cathode supply must be reset by inserting a nonconducting rod (PVC or nylon) through the cage and depressing the green square button near the left edge of the supply front panel.
23. Increase the Ionizer current in four ampere steps separated by intervals of five minutes until the desired operating current is achieved (normally 23 amps).
24. The cathode change is now completed. The source exit valve can be reopened and the preaccelerator brought back to voltage after the source vacuum has recovered to $\sim 1 \times 10^{-6}$ torr. The inflector magnet and source supplies can now be tuned for the desired ion and beam current on the L.E. cup.

12 Outgassing a New Ionizer

*****DO NOT RUN THE IONIZER OVER 290 WATTS*****

1. Since the source has just been rebuilt it will need to be pumped on for at least three hours. After this time the vacuum should be in the low 10^{-6} torr range if there is no leak. Note in the logbook the source vacuum indication previous to outgassing the ionizer filament. If the vacuum has not reached this level in five hours a leak may be present and it will have to be corrected prior to heating the ion source filament.
2. The ionizer is typically left with a small current flowing through the ionizer after the rebuild just to ensure continuity. Assuming the vacuum has recovered, increase the ionizer current in three ampere steps every thirty minutes. If the vacuum has degraded to over 5×10^{-6} torr due to a previous current increase, hold off on subsequent increases. When the vacuum has returned to 5×10^{-6} torr or less begin the three ampere increases again.

3. When the Ionizer filament power is up to 290 watts for 30 minutes and the vacuum has improved to better than 5×10^{-6} , begin looking for beam on the L.E. cup. Go to Sec. 7 for instructions for tuning beam out of the source. Instabilities in the Cathode and Extractor high voltage elements will cause the beam current to be erratic and can be an indication of poor vacuum in the ionizer region. The voltage instability also appears on the high voltage supply meter indications in the source high voltage cage. Patience or a reduction in the filament power level, if beam current requirements allow, should correct this problem. Regardless, reduce the ionizer temperature if possible to prolong its operational lifetime.

13 Ion Source Shutdown and Disassembly

1. In the Control Room, ensure the L.E. Faraday Cup is in and the preaccelerator is switched off. Turn down and off the Source Deflectors.
2. In the Tandem Vault, close the source exit valve.
3. Reduce the Cesium Boiler Heater to zero on the variac scale by turning the control rod located at the high voltage cage.
4. Reduce the Ionizer Heater current to zero amperes in four ampere steps separated by two minute intervals by turning the control rod attached to the Ionizer Heater power supply located at the High Voltage Cage.
5. Leave the source to cool for an hour and thirty minutes then turn the cooling water off.
6. Turn off the Cesium Feed Line Heater by depressing the illuminated power button with an insulated rod.
7. Turn down the Extractor and Cathode H.V. supplies by turning the control rods attached to each power supply at the High Voltage Cage.
8. Reduce the einzel lens voltage to zero by depressing the labeled rocker switch at the H.V. cage control panel. Turn the key switch at the panel to turned off the isolation transformer providing platform power to the H.V. cage. Both the Source and H.V. Cages may now be opened.
9. Using the shorting rod that is hanging on the cage at the stainless steel U-bolt, touch the source on each side of the endmost ceramic insulator to reference the stainless steel elements to ground. Hang the shorting rod between the air lock VAT valve and the HPS vacuum fitting clamp.
10. Access to the external source body is now possible. If breaking vacuum is necessary for work to proceed then continue with this list. If the source is to be let up to Argon, proceed.

11. Turn off the cold cathode vacuum gauge. Verify that the source exit valve is closed.
12. Close the diffusion pump gate valve. The source may now be back filled to atmospheric pressure with argon: open the cylinder valve and adjust the regulator for 10 psi, open the flow gauge valve several turns, open the valve attached to the source vacuum box, adjust the flow to 10 L/min. Allow the gas to flow into the source box until the pressure relief valve on top of the source vacuum box indicates excess flow. Close the valves associated with letting up the source.
13. After five minutes feel the end flange of the source to see if it is warm. If it is warm allow the source to sit until it is cool to the touch.
14. The cesium boiler assembly may now be dismantled so that the cesium reservoir can be removed. Be very careful when removing the reservoir because some Cesium vapor may have condensed around the VCR gaskets. The NEC “Cesium Saver” may be used to protect the cesium from contamination; if needed, its use is described in the NEC Instruction manual.
15. Remove the H.V. cathode lead from the stop clamp aluminum bar attached to the cathode assembly.
16. Ensure the compression fitting sealing the cathode assembly is only finger tight and then withdraw the assembly.
17. Access to the source inner components is obtained by removal of the electrical connections, the cathode air lock valves and quick connect seals and the end most 12 hole flange. Be careful on removing the flange so that damage is not done to the parts mounted on the inside surface.
18. When the source work is finished and it has been reassembled, the source can be roughed out by turning on the roughing pump at the fuse box mounted beneath the H.V. cage by the mechanical pump which connects to the source vacuum box by PVC piping. Open the ball valve between the source box and the pump. Close it at a source vacuum of 300 millitorr. Shut down the roughing pump and let the roughing line up to air with the valve mounted on the PVC near the pump.
19. Place the backing and baffle valves in the “unprot” mode and open the baffle valve. When the vacuums are below the set points for the respective controllers, place the backing and baffle valves back to the “protect” mode.
20. Reconnect the electrical leads removed from the source, install a cathode and close the source cage.
21. Vacuum permitting, the source is ready to be brought back to operating voltage, current and temperature.

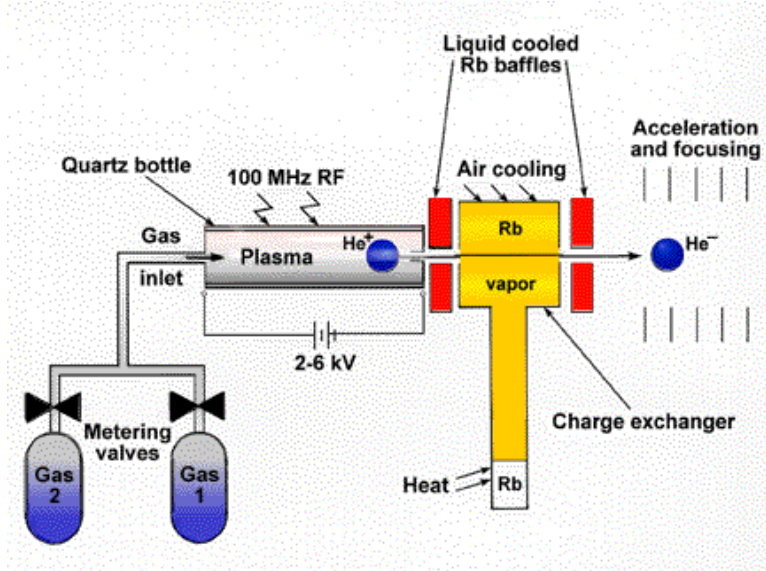

Figure 8: RF Source Diagram

14 RF Source Operation

(See figure 8).

14.1 Operating Principle

Helium is admitted into a quartz tube at a few mtorr where it is ionized to He^+ in an RF discharge. The ions are extracted through a tantalum exit canal by applying a 4 kV positive bias to the anode at the other end of the tube. Most of the anode bias potential is dropped across a small region near the exit canal and the field lines have the effect of focusing and accelerating the ions through the canal. The ions emerge with an energy close to the anode potential. A large coil around the quartz tube produces a magnetic field which improves the coupling of RF power into the discharge. The He^+ ion beam from the exit canal is focused by a gridded einzel lens (see figure 9) working in accel-decel mode with a bias of about -4.5kV to form a waist at the Rubidium vapor charge exchange cell. About 1% of the He^+ entering the REC should get converted to He^- in the $1s2s2p\ ^4P_{5/2}$ metastable state. The negative ion lifetime of approximately 0.5ms is sufficient to reach the Tandem terminal stripper foil.

14.2 RF Discharge Contaminants

Because oxygen and other species form negative ions with efficiencies much higher than helium the He^+ beam is only a fraction of the total positive beam, hence the He^- beam is a small fraction of the negative beam. The admitted helium and desorbed gases from the RF source bottle and boron nitride exit canal insulator are some sources of the contaminant beams. For optimum performance it is essential that the RF source bottle

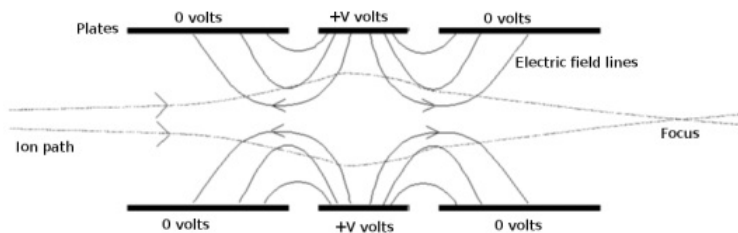

Figure 9: Einzel Lens Diagram

assembly be leak tight, that the helium used be greater than 99.99% pure, and that all He tube and fittings be clean. In addition, it is also important to operate the RF discharge with the helium flowing for 1 or more days prior to the accelerator beam time to allow some of the contaminants to dissipate.

14.3 Summary of Operation

1. Check that the setup procedures have been properly carried out. In particular ensure that the anode HV supply (OPPLIS PMT supply) has been disconnected from the PMT and has been set to the positive polarity.
2. Turn on the ENI blue RF amplifier and power supply for the 114 MHz oscillator. Set the attenuator between the oscillator and amplifier to 10db; the output will be more than 30W.
3. Open the valve on the red helium bottle. Open the helium leak until the discharge starts. Close it until the discharge is no longer pink and has become blue. The spherical deflector denoted Penning gauge should only read a few 10^{-6} torr.
4. Turn on the anode high voltage and set to +4 kV. (To use the program set the remote/manual switch at the back to remote).
5. Turn on the einzel lens supply. Set to 4.5 kV using the program.
6. Insert cup-1 em (use the control program) and optimize the positive current by varying the gas pressure.
7. Turn on the magnet supply (HP power supply). Optimize the positive current with respect to magnet current. Note: There are strange “hysteresis” type effects in the discharge. The magnet current which was previously “optimum” is often not the optimum on a subsequent optimization attempt.
8. Focus the positive beam onto cup-2 using the einzel lens “focus”, Q1 and the deflectors.
9. Analyze for He^+ using the Wien filter:

- (a) Set WF electrostatic to 160V.
- (b) Step the WF magnet current up from zero and monitor cup-2 current. He^+ should occur at about 265 mA. If the source has not been run recently 300 nA of analyzed He^+ on cup-2 is typical.
- (c) Continue scanning to 1000 mA and look for other strong peaks.

It has been found that better transmission can be obtained by operating at reduced Wien voltage, and correspondingly reduced Wien magnetic field.

10. To allow some of the contaminants to dissipate operate the RF discharge with the helium flowing for 1 or more days prior to the accelerator beam time. After this purge period the analyzed He^+ beam on cup-2, after optimizing the focusing, should be more than +5 microamperes. If it is not, try adjusting the gas leak and magnet current. Adjustment of the gas, however, may be frustrating: increasing the flow usually increases He^+ output temporarily, followed by a decrease and vice versa.
11. Increase the cesium charge exchange canal middle tube section temperature setting to 150 C.
12. Monitor the temperature rise. At about 100 C the positive current reading on cup-2 should start to fall; at about 135 C the current should pass through zero. The beam collected will consist of contaminant species and ions rendered neutral by the charge exchange canal some of which will pass undeterred by the Wien filter to cup-2. The beam current indication therefore is not due to helium alone and can be misleading as demonstrated by the reading becoming positive when the source platform is raised to high voltage. At 150 C you should see on the order of - 50nA at cup-2.
13. Close the source cage, and follow the instructions for Changing Ion Sources in Sec. 5 of this lab guide. Check for isolation of the platform from ground and nearby objects.
14. Raise the preaccelerator voltage to 80kV.
15. Look for beam on the LE-cup and the source scanner. There should be a beam on the scanner which does not respond to the inflector magnet or the deflectors, and superimposed, a beam which does. The non-responsive beam is the neutral helium and contaminants, the responsive beam is the negative He and contaminants.
16. Inject the beam into the tandem and analyze on BS-1 or BS-2. Carefully check the NMR reading and terminal voltage (allowing for the offset in the GVM reading) to ensure that it is He^{++} which is being analyzed. $^{16}\text{O}^{6+}$ can be transmitted with the same NMR setting for He if the terminal potential is roughly 200kV over the required setting.

17. Using the program and other controls, optimize the He current on the beam stop. A current of 50 to 100 nA on the beam stop should be expected.

Another set of instructions is contained in the file helisop.hlp. To obtain a printout, exit the OPPLIS control software, hook up a printer and type: print helisop.hlp (return).

15 RF Source Tuning Instructions with the PC

15.1 Focusing and Steering Control

Use the arrow keys to move the highlighted rectangle to the “device” column and then to the specific element in that column you wish to adjust. After the particular lens or deflector is highlighted use the right arrow key to move to the “setnow” column and press the “F” key. Tuning of the chosen device is done by pressing the up and down arrow keys to arrive at the optimum setting. Using the left arrow to return the highlighted rectangle to the “device” column will set the devices operating parameters.

15.2 Optimizing on Source Cup-2

Press the “N” key to allow beam current to be measured at cup-2; the current is displayed at the lower center of the control screen. If the output is less than 100 nanoamperes of negative beam follow the “A” set of instructions below. If the current is 100 nanoamperes of negative beam or greater the source is operating well and one should follow the “B” instructions.

A) Press the “P” key and observe the beam current on cup-1. It should be 40 to 80 microamperes of positive beam. If the reading is less, adjustment of the discharge gas pressure is necessary. Due to the location for gas adjustment it is not physically possible to monitor the effect of the pressure change at the computer screen so a digital volt meter must be connected to the coax cable labeled “cup-1” near the flow control valve to measure changes in beam current. Open the Helium gas flow control valve at the RF discharge tube inlet in steps no greater than a 12 degree turn of the control rod; the effect should be noticeable within seconds. If the beam output doesn’t reach 40 microamperes seek assistance from Brian Schmidt.

When the cup-1 beam current has reached 40 to 80 microamperes remove the cup from the beam path and adjust the Wein Filter electrostatic voltage while monitoring current at source cup-2. If the current still is not -100 nanoamperes check the status of the light blue vacuum protection panel located in the source cage: if the red light is on simultaneously press the two reset buttons on the panel. If the vacuum protection panel has not tripped and beam output hasn’t reach 100 nanoamperes of negative beam at cup-2 seek assistance from Brian Schmidt. When adequate beam is attained at cup-2 follow instructions “B”.

B) The current on the LE cup should be 50-100% of source cup-2. If it is less than this, the source needs some additional tuning. Press the “E” key and then try to small adjustments of the Wein filter electrostatic voltage while observing beam either at the LE cup or the HE tandem cup-1. Increases in beam transmission may also be found by fine tuning the source exit deflectors (rack mounted in the control room above the PC screen), quadrupole-2 (adjusted with the computer software) and the inflector zero supply (located in the control room above rack “G”).

Typical Beam Currents:

Source Cup-1 = 40-80 microamperes positive

Source Cup-2, With the Preaccelerator Off = 100-150 nanoampers negative

Tandem L.E. Cup = 100 nanoamperes negative

Tandem H.E. Cup = 50-100 nanoamperes positive

16 Hardware/Cable Changes for Switching Target Rooms

16.1 From the Tandem Target Room to the LINAC Target Room

Ensure all appropriate supplies are off!

1. The Slit Stabilization Amplifier is shared between the Tandem and LINAC 90° magnets. Unplug the 110 volt power cord and disconnect the output signal cable D-type connector from the amplifier and terminate it at the LINAC Slits Connector Box. Detach the two coax cables from the image slits and move the amplifier to the LINAC 90° magnet image slits. Connect the coax cables to the image slits; ensure that the H.E. and L.E. slits are coupled to the correct amplifier inputs. Connect the Cannon connector to the slit amplifier; it should be laying in the vicinity of the image slits. Plug the 110 volt power cord into a receptacle.
2. Check the external second stripper in the LINAC hall for the presence of a foil in the beam path and the condition of the foil if stripping to a higher charge state is required.
3. Open each Tandem 90° magnet object slit to 0.2” on both the horizontal and vertical pairs.

4. The switching magnet in the Tandem Target Room uses the same power supply as the magnet which serves the LINAC Target Room. Ensure the supply is turned off in the Control Room. The power supply and the enclosure housing the beam routing knife switches are located in the Tandem Vault, in the rack to the North of the H.E. entrance. The output of the supply is switched to the Tandem Target Room switching magnet with the top knife switch and the polarity for the correct beam deflection with the bottom.
5. Ensure both the LINAC 90° and switching magnets have cooling water (cooling lines should be cool to the touch).
6. Close the Tandem Target Room switching magnet beamline valve. Ensure the vacuum in the Tandem 90° magnet, H.E. beam line and LINAC line are below 1×10^{-5} torr. If this is so, open the hand valve before the 90° magnet and the LINAC line pneumatic valve.
7. To degauss the old 90° magnet rundown the current at the control panel, change the deflection for the reverse mode, increase the magnet current a few amps, then back down and return to the normal deflection mode.
8. In the Control Room, exchange the input connector for the Gauss Meter from the one for the Tandem to that labeled for the LINAC.
9. Control of deflectors D-1, D-2, QIII-A and QIII-B is obtained by dropping the switch at the bottom of rack F to the position labeled LINAC. Ensure the appropriate supplies are off before making the switch.
10. The beam chopper for the LINAC should have the amplifier turned on in the Tandem Vault, Southwest of the Tandem Target Room 90° magnet. Ensure the drive signal for the amplifier in the Control Room LINAC electronics rack is unplugged when first tuning beam.
11. Turn around the sign on the LINAC Hall entrance door to indicate the presence of beam and then secure the door so that entry can only be made via the control room. Close the gate separating the Tandem target room from the LINAC Target Room.

16.2 From LINAC Target Room to Tandem Target Room

Ensure all appropriate supplies are off!

1. The Slit Stabilization Amplifier is shared between the Tandem and LINAC 90° magnets. Unplug the 110 volt power cord. Remove the amplifier output signal cable multi-pin Cannon connector and lay it down in the cable tray. Detach the two coax cables from the image slits and move the amplifier to the Tandem 90° magnet image slits. Connect the coax cables to the image slits; ensure that the

H.E. and L.E. slits are coupled to the correct amplifier inputs. Remove the Cannon connector from the LINAC Slits Connector Box and connect it to the slit amplifier box. Plug the 110 volt power cord into a receptacle.

2. Close each horizontal object slit to 0.115" on the Tandem 90° magnet. Open the vertical object slits all the way.
3. The beam chopper for the LINAC should have the amplifier turned off in the Tandem Vault, Southwest of the Tandem Target Room 90° magnet.
4. The switching magnet in the Tandem Target Room uses the same power supply as the magnet which serves the LINAC Target Room. Ensure the supply is turned off in the Control Room. The power supply and the enclosure housing the beam routing knife switches are located in the Tandem Vault, in the rack to the North of the H.E. entrance. The output of the supply is switched to the Tandem Target Room switching magnet with the top knife switch and the polarity for the correct beam deflection with the bottom.
5. Ensure that both Tandem 90° and switching magnets have cooling water (cooling lines should be cool to the touch).
6. Close the LINAC beam line pneumatic valve. Ensure the vacuum in the Tandem 90° magnet, H.E. beamline and switching magnet are below 1×10^{-5} torr. If this is so, open the hand valve before the 90° magnet and the switching magnet pneumatic valve.
7. In the Control Room, exchange the input connector for the gauss meter from that for the LINAC to that labeled for the Tandem. Ensure the Tandem 90° magnet is in the correct deflection mode. If not turn supply down before making the switch.
8. Control of deflectors D-1, D-2, QIII-A and QIII-B is obtained by raising the switch at the bottom of panel F to the position labeled Tandem. Ensure the appropriate supplies are off.
9. Close the gate between the two Target Rooms. Rope off the passage between the Tandem Vault and the LINAC Hall.

17 Hardware/Cable Changes for Choosing a Beam-Line out of the Switching Magnets

17.1 LINAC Target Room Switching Magnet

Ensure all appropriate supplies are off!

1. The switching magnet in the Tandem Target Room uses the same power supply as the magnet which serves the LINAC Target Room. Ensure the supply is turned down in the Control Room. The power supply and the enclosure housing the beam routing knife switches are located in the Tandem Vault, in the rack to the North of the H.E. entrance. The output of the supply is switched to the Tandem Target Room switching magnet with the top knife switch and the polarity for the correct beam deflection with the bottom.
2. Move the power cable for Q-4 to the appropriate experimenter's quadrupole in the LINAC Target Room.
3. Control of the deflector D6 and measurement of beam current by Faraday Cup no.6 on the experimenter's beam line is enabled by making the correct connections at the labeled patch panel on the LINAC switching magnet support stand. Beam current measurements provided for in the experimenter's chamber can be made by making the correct connection to TC-2 at the switching magnet patch panel; this panel faces West below the magnet.
4. Move the roving Faraday cup controller to the experimenter's beamline and connect the controller cable at the cup.

17.2 Tandem Target Room Switching Magnet

Ensure all appropriate supplies are off!

1. The switching magnet in the Tandem Target Room uses the same power supply as the magnet which serves the LINAC Target Room. Ensure the supply is turned down in the Control Room. The power supply and the enclosure housing the beam routing knife switches are located in the Tandem Vault, in the rack to the North of the H.E. entrance. The output of the supply is switched to the Tandem Target Room switching magnet with the top knife switch and the polarity for the correct beam deflection with the bottom.
2. The beam current is measured on beam dumps for each individual beam line. Connection to the current integrator in the Control Room is made locally with a coax cable terminated with an alligator clip.
3. The beamline deflector, as of this writing, is physically dedicated to a beam line and must be moved to a new beam line with the help of a few hand tools.
4. The Quadrupole power supply is located in the Tandem Target Room next to the Tandem Vault shield door. The out put of the supply is switched to the new beam line at the quadrupole. Move the lead to the new quadrupole and plug it in.

18 Tandem Beamline SF₆ Gas Security Ball Valves

Each beam line exiting the Tandem has a large diameter, pneumatically actuated Worcester Controls ball valve that will automatically close under normal operating conditions if a pressure rise on the order of in. of Hg is detected on the Tandem side of the valve. Because the Tandem is filled with SF₆ at 85 psi and the accelerator tubes and beamline are under vacuum a failure of an O-ring seal, accelerator tube metal to glass bond or any major compromise of vacuum integrity within the machine could have catastrophic results. The intention of the valves are two fold. One is to contain the gas to prevent its loss, a \$70,000 investment. The other is to prevent damage to the equipment on the beam line that is designed to withstand the implosive forces of vacuum and not the explosive 85 psi tank pressure.

An Edwards High Vacuum Ltd. pressure switch is located on the L.E. end of the Tandem beam line to sense the fault condition along with a 30 in. Hg to 60 psi compound gauge to monitor the tube vacuum/pressure in the range where penning gauges and thermocouples are not usable. The control panel is in the vault L.E. electronics rack below the beamline, and the key switch for disabling control of the ball valves is kept in the red case underneath the Control Room console. When the vault control panel is in the unprotected key switch position the ball valves can be opened and closed at will. In the protect position the ball valves can only be opened when the beamline pressure switch is closed. An LED on the control panel, labeled sensor contact, will illuminate when the switch is closed.

The Gas Security Ball valve controller is integrated with the Tandem Pelletron interlock circuit. A closure of the ball valve either manually or due to a failure of the vacuum integrity is sensed by the Ball valve controller and results in the Pelletron charging supplies being interrupted via the interlock panel.

Because they are pneumatically controlled, a loss in compressed air service will result in the valves closing. There will be no electric circuit indication such as the sensor contact LED being off or the Pelletron H.V. supplies being tripped off. If beam transmission through the machine is nil, investigating the ball valves themselves will allow ascertaining the valves' state. On top of the pneumatic actuators are square posts that turn with the ball valve, the valves are open if the small silver stud on one of the flats is facing West.

19 Tandem Beamline Vacuum Protection System

The logic and status chassis for the Tandem Vault beam lines is above the switching magnet power supply, North of the H.E. vault shield door. There is a status panel also in the Control Room above the beamline devices panel (figure 4). The L.E., H.E., Sputter Source and Polarized Source vacuum indications are displayed in the Control Room also.

Each Tandem beamline fast valve has a dedicated control box and penning gauge except for the 90° magnet which has a penning gauge but no fast valve to control. Each

controller has a “good vacuum” output signal that is “anded” together in the logic chassis with the other controllers. If any of the five penning gauge controllers detect a vacuum incident, all four of the fast valves will close and the Tandem Pelletron charging H.V. supplies will be disabled.

The Tank Gas Security Ball Valve Controller is also “anded” with the beamline penning gauge controllers in the logic chassis and an LED indication for the ball valves status is provided. If either the L.E. or H.E. Gas Security ball valve is closed, the Pelletron H.V. charging supplies are disabled. If the ball valves have closed on their own something could be severely wrong and a staff member familiar with this system should be consulted before they are reopened. More information about the Gas Security ball valves can be found in Sec. 18.

The source penning gauge is not included in the “anded” logic to close the beamline valves. The source penning gauge will close the source exit valve and turn off the preaccelerator H.V. supply if the ion source vacuum sufficiently degrades. The valve control boxes for the two sources are different, so, arbitrary interchanging of the boxes cannot be done.

The fast valve control box/penning gauge controllers themselves do have many common features. The valve control boxes can be used to open and close a valve at will in the *unprotected* mode (no vacuum consideration). In the protected mode, the valve can only be opened if the vacuum at the associated gauge head is better than the chosen set point, approximately 5×10^{-6} . A controller that has sensed a vacuum excursion will have a flashing LED; to rearm the protection circuit and open the valve(s) that has tripped close, depress the push button reset switch on the front panel of that controller, the LED should stop flashing. Be cautious with the beamline valves: if all the controllers sense a good vacuum and all valve switches are in the *open* position, all four fast valves will open simultaneously. If this is not desired, place the valve control box switches to *close*, reset the tripped penning gauge controller, and then open the valves individually.

If a penning gauge controller is out of service or it is desirable to prevent a controller from closing the beam line valves, it can be overridden at the logic panel by placing the switch indicated for that controller in the *override* position. The Ball valves should only be overridden after a staff member familiar with this system has been consulted.

20 Tandem Pelletron Interlock Panel

To prevent dangerous operation of or damage to the accelerator an interlock circuit is employed. The status of the various interlock switches is displayed at the interlock panel. The switches and their status are in a serial configuration therefore should one interlock not be closed all others “down stream” will also indicate an open situation and the LEDs will be extinguished. The panel layout is natural in that all the LEDs to the right of the offending switch will be out; once that interlock is satisfied its LED will illuminate and the rest to its right should also shine if the switches are closed. The interlock circuit, depending upon which switch opens up, will either turn off the charging supplies or both the charging supplies and the chain drive motors. All the interlocks up

to and including the tank pressure switch will disable both the chain drives and power supplies, the remaining only affect the charging supplies.

There are nine LEDs on the Tandem Pelletron Interlock Panel, see figure 10. A brief description of each interlock or LED indication in the order that they appear on the panel follows.

Status Power: This lamp will be lit if the power switch key is turned to on and the 12V dc supply used for the series circuit is present.

Control Power: This lamp indicates AC power is present within the chassis when the switch key is turned to on.

HE Tank Door: A push button switch is mounted on the Tandem High Energy Tank Door to sense when the door is fully rotated closed.

LE Tank Door: A push button switch is mounted on the Tandem Low Energy Tank Door to sense when the door is fully rotated closed.

LE Pendulum: A push button switch is mounted to the LE drive sheave assembly to sense excessive Pelletron chain stretch or failure.

HE Pendulum: A push button switch is mounted to the HE drive sheave assembly to sense excessive Pelletron chain stretch or failure.

Tank Pressure: A pressure switch is mounted to the Tandem pressure vessel to ensure a minimum pressure of 35 psi is established before the Pelletron chain is started.

Vac Ball Valves: This interlock is closed when the Tandem Beam Line Valve Protection System detects no tripped penning gauge controller or beamline SF₆ protection ball valve closure. A separate status panel is present in the Control Room for this beamline protection system and an override/status panel is located in the Tandem Vault to the North of the HE door. A more detailed description of that circuit can be located through the Table of Contents.

TPS OV/UV: The Terminal Potential Stabilizer supplies a relay that relaxes whenever the terminal voltage varies beyond a set percent of the value displayed at the terminal voltage reference potentiometer. This TPS feature must be enabled to trip the interlock panel for an out of range voltage excursion.

Should a condition arise where disabling the Tandem Pelletron Interlock Panel is desired, such as a tank opening, an override switch is located in the back of the panel chassis. It is accessible from behind the electronics racks.

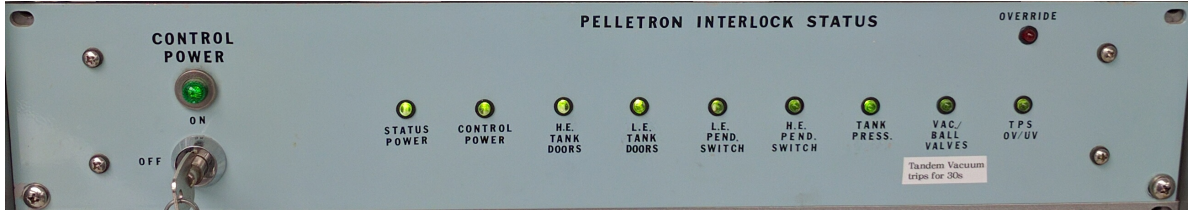

Figure 10: Pelletron Interlock Panel

21 Terminal Potential Stabilizer

The Terminal Potential Stabilizer (TPS) consists of five main components: Controller Unit, Generating Voltmeter (GVM), Analyzing Slits, Capacitive Pick-Off Plates (CPO) and the Corona Probe.

- The Controller as is suggested, controls the terminal voltage by comparing signals from the GVM, slits and the CPO to produce a correction signal that modulates the current flowing to the terminal from the corona probe.
- The GVM is mounted on the tank wall of the Tandem opposite the terminal. A four bladed rotor spins at 3450 rpm over a surface divided into eight segments each the size of one blade. As the rotor spins it uncovers some segments and exposes them to the terminal voltage which results the segment charging to a voltage proportional to the terminal voltage. When the segment is again shielded by the rotor, charge will drain away. The signal produced by the GVM is conditioned locally by an amplifier and routed to the controller.
- The analyzing slits are in the typical configuration, downstream of the 90° analyzing magnet, parallel to the pole face plane and opposite each other on the exiting beamline. They are adjustable with micrometer style knobs for each and are electrically isolated. Beam being bent around the 90° magnet impinges upon the slits creating a signal proportional to the beam it senses. The signals from the slits are conditioned locally by an amplifier and routed to the controller.
- There are two CPO plates in the Tandem that are mounted on the tank wall opposite the terminal. These plates are electrically isolated and sense fluctuations of terminal voltage at frequencies above those detectable by either the slits or the GVM. Two plates are used to cancel out physical movement of the column that would be detected as a voltage fluctuation by a single plate as the separation between the terminal and plate changes. The signal from the CPO plates is conditioned locally by an amplifier and routed to the controller.
- The corona probe is also mounted on the tank wall opposite the terminal. The probe is mounted on a shaft that can be driven to different distances to the terminal depending on the terminal operating voltage. The end of the probe consists of a shell with 12 needle points extending slightly beyond the polished shell surface.

The voltage on the needle points determines the flow of electrons to the positively charged terminal. Modulating this flow of electrons is done by the Controller based on the information provided by the GVM, slits and the CPO.

The typical operation of the system is described to assist the operator in understanding how the system maintains terminal stability. The description is not intended to be used for bringing up the terminal voltage as it excludes the Charging Controllers and positioning of the corona probe. Feedback or modulation of the probe current will take place only when the TPS Control Gain is turned up. The Controller has three possible modes of operation namely GVM, Slit or Auto. The Auto mode allows the TPS to switch into one of the other two modes depending whether the terminal voltage is approximately 50 KV off of the controller Terminal Voltage Reference Potentiometer setting and/or beam current above 10 nanoamperes is sensed by the analyzing slits. Typically the Controller is in the Auto mode.

With less than 10 nanoamperes of beam on the analyzing slits, the Tandem will be in GVM mode. The correction signal in this mode is derived by comparing the front panel Terminal Voltage Reference Potentiometer setting to the GVM measurement of actual terminal voltage. The CPO signal is added to this to produce the error signal that ultimately modulates the corona probe voltage. The operating voltage of the probe needles is proportional the Grid Bias indicated on the Controller chassis. In this mode the terminal voltage will track the Reference Potentiometer setting and allows one to scan the terminal voltage until beam strikes the analyzing slits.

With beam on the slits and the GVM and Terminal Voltage Reference Potentiometer in relative agreement the TPS Controller will switch to Slit mode. The controller compares the current striking one slit to the other to create an error signal that attempts to keep the measured current balanced. The slit on the inside of the analyzing magnet bend is the Low Energy (LE) slit and the one on the outside is the High Energy (HE) slit. If an excess of beam is detected by the LE slit an error signal is produced by the TPS that will reduce the probe electron current flowing to the terminal causing the terminal voltage to rise which will bring more beam current to bear on the HE slit until a balanced situation is again reached. Like the GVM mode, the CPO signal is added to modulate the probe current. In this control mode adjusting the Terminal Voltage Reference Potentiometer has no effect until the disagreement with the GVM causes the TPS to revert to GVM mode. When the TPS is in Slit mode the Reference Potentiometer should be adjusted to agree with the GVM indication.

22 Operating Instructions for the Tandem Pelletron

22.1 To Turn the Tandem Pelletron On

- Set the TERMINAL POTENTIAL STABILIZER CONTROL MODE to AUTO and turn the CONTROL GAIN and CPO GAIN to zero.
- Turn on the LOW ENERGY CHARGING CONTROLLER AND THE HIGH

ENERGY CHARGING CONTROLLER by turning their key switches CW to the ON position. To start the charging chains lift the momentary CHAIN switch to the ON position for each CONTROLLER. After approximately ten seconds the lamp below the switch will illuminate indicating the chain is up to speed.

- Set the corona probe BIAS CURRENT to 35 microamps on the TPS
- Set the corona probe to the approximate position indicated in the table for the desired terminal potential.
- Set the GVM REFERENCE VOLTAGE knob to the correct voltage (e.g. 8 MV would be “0800”).
- Ensure the TERMINAL CHARGE POTENTIOMETER on the LOW ENERGY CHARGING CONTROLLER is turned down to zero, CCW.
- Turn both POWER SUPPLY switches to ON on the CHARGING CONTROLLERS. Their indicator lamps should glow.
- While watching the corona probe GRID voltage, carefully increase the charge carried by the chains by turning the TERMINAL CHARGE POTENTIOMETER CW. Turn the TERMINAL CHARGE POTENTIOMETER until the GVM/TV Balance indicates approximately zero or the GRID voltage has reached -9V. If at any time the GRID voltage reading goes beyond -10V, run the corona probe out to reduce it. Fine tune the corona probe position and the up-charge so that the GRID voltage reads approximately -9V when the desired terminal voltage is reached.
- Enable the OVER/UNDER VOLTAGE PROTECTION and set both the CONTROL GAIN and CPO GAIN to 5.
- Readjust the corona probe if necessary to attain -9V; do not exceed this voltage on the GRID.
- Set the 90° magnet to the appropriate field and put beam through the Tandem. If the TPS does not switch to the SLIT CONTROL MODE and lockup on a beam the GVM REFERENCE VOLTAGE knob can be adjusted slightly to scan for the beam; only a slight adjustment should be necessary.
- With beam on the slits, and the TPS in SLIT CONTROL MODE adjust the TERMINAL CHARGE POTENTIOMETER so that the Slit Balance meter reads zero, and retrim the corona probe position, if necessary, to get -9V on the GRID.
- Adjust the GVM REFERENCE VOLTAGE knob so that the GVM/TV Balance meter indicates approximately zero.

IF THERE IS A SPARK

The OVER/UNDER VOLTAGE PROTECTION interlock on the TERMINAL POTENTIAL STABILIZER panel will be tripped and the red LED should be lit. The CHARGE CONTROLLER POWER SUPPLIES are disabled by this protection circuit, however, the chains will continue to run.

- Turn the CONTROL GAIN and CPO GAIN to zero
- On the LOW ENERGY CHARGING CONTROLLER turn the TERMINAL CHARGE POTENTIOMETER back to zero.
- Reset the TPS OVER/UNDER VOLTAGE PROTECTION interlock by depressing the momentary switch.
- Turn up the TERMINAL CHARGE POTENTIOMETER until the previous terminal potential is reached; watch for signs of conditioning.
- Check that the GRID voltage reads approximately -9V .
- Set the CONTROL GAIN and CPO GAIN to 5.
- Put beam through the Tandem Pelletron and adjust the TERMINAL CHARGE POTENTIOMETER to center the Slit Balance meter.
- Enable the OVER/UNDER VOLTAGE PROTECTION circuit.

22.2 To TURN OFF the Tandem Pelletron

- Disable the TPS OVER/UNDER VOLTAGE PROTECTION and turn the CONTROL GAIN and CPO GAIN to zero.
- Turn the CHARGE CONTROLLER TERMINAL CHARGE POTENTIOMETER back to zero and turn off the CHARGING POWER SUPPLIES at the toggle switch. Depress the momentary switch for the chains to turn them off and then turn the panel key switch to off.

22.3 To Change the Terminal Potential

- Disable the TPS OVER/UNDER VOLTAGE PROTECTION and turn the CONTROL GAIN and CPO GAIN to zero.
- If the terminal potential is to be decreased, reduce the CHARGE CONTROLLER TERMINAL CHARGE POTENTIOMETER until the TPS displays the TERMINAL VOLTAGE desired. Typically the terminal voltage will drop as the corona probe is run in requiring increases of chain current. Adjust the corona probe position and the TERMINAL CHARGE POTENTIOMETER to get approximately -9V on the GRID.

- If the terminal potential is to be increased, run the corona probe out to the approximate position indicated in the table for the desired terminal potential. While watching the corona probe GRID voltage, carefully increase the CHARGE CONTROLLER TERMINAL CHARGE POTENTIOMETER. Increase the TERMINAL CHARGE POTENTIOMETER until the TPS displays the TERMINAL VOLTAGE desired or the GRID voltage has reached -9V. If at any time the GRID voltage reading goes beyond -10V, run the corona probe out to reduce it. Readjust the corona probe position and the TERMINAL CHARGE POTENTIOMETER so that the GRID voltage reads approximately -9V at the desired terminal voltage.
- Adjust the GVM REFERENCE VOLTAGE knob so that the GVM/TV Balance Meter indicates zero.
- Enable the TPS OVER/UNDER VOLTAGE PROTECTION and turn the CONTROL GAIN and CPO GAIN to five.
- Readjust the corona probe if necessary to attain approximately -9V on the GRID; do not to exceed this voltage.
- Set the 90° magnet to the appropriate field and put beam through the Tandem Pelletron.
- If the TPS does not switch to the SLIT CONTROL MODE and lockup on a beam the GVM REFERENCE VOLTAGE knob can be adjusted slightly to scan for the beam; only a slight adjustment should be necessary.
- With beam on the slits, and the TPS in SLIT CONTROL MODE adjust the TERMINAL CHARGE POTENTIOMETER so that the Slit Balance meter reads zero; retrim the corona probe position, if necessary, to get approximately -9V on the GRID.
- Adjust the GVM REFERENCE VOLTAGE knob so that the GVM/TV Balance meter indicates approximately zero while the TPS is in SLIT CONTROL MODE.

23 Extended Tandem Pelletron Shutdown

If the current experiment has concluded and machine downtime is expected, the following list should be followed. Ensure a log sheet has been filled out that includes all the beamline devices (figure 4) settings, Faraday cup currents, Tandem parameters,...etc.

1. Return beam to the L.E. Faraday cup.
2. Turn the Terminal Potential Stabilizer Control and CPO Gain to zero, Disable the over/under voltage protection.
3. Turn the Terminal Charge Potentiometer on the Low Energy Charging Controller down to zero, CCW.

4. Turn both power supply switches to off on the Charging controllers.
5. Stop the charging chains by depressing the momentary chain switch to the off position for each Controller.
6. Turn off the Low Energy Charging Controller and the High Energy Charging Controllers by turning their key switches CW to the off position.
7. Turn down the supplies for these devices:
 - (a) switching magnet
 - (b) 90° magnet
 - (c) Target room quadrupoles and deflectors
 - (d) accelerator quadrupoles and deflectors
 - (e) L.E. beamline lens 2.
8. Close the hand valve before the Tandem 90° magnet.
9. Follow the source turn down instructions (Sec. ??).
10. Remove control power key if a tank opening is required.

24 Terminal Stripper Foil Changer

A change in terminal stripper foil is indicated by a decrease in beam transmission through the Tandem. To change the foil one of the two rocker switches on the foil changer panel in the Control Room should be depressed. The direction of movement, either forward (increment) or reverse (decrement) should be that which would bring a fresh foil into the beam path, consult the logbook for used foil information. Motion of the foil band will continue while a switch is pressed. When the direction of the foil change is reversed a considerable amount of backlash, inherent with magnetic couplings, will result in a longer period than for the initial foil change. Use the rocker switches to maximize beam transmission through the Tandem.

The foil changer can be placed in an automatic change mode that allows the foil to be incremented or decremented to a preset number. On the foil changer panel is a thumb wheel numeric display that should be adjusted to indicate the desired foil number. A small toggle switch is located at the left corner of the display should be switched to the “ena.” (enable) mode. The preset push button should be depressed, the labeled LED below the display should light. Now depress the rocker switch that will allow the foil changer to either increment or decrement to the chosen value. Fine tuning of the foil will be required after the preset is reached. When finished with the preset function put the toggle switch back to the “dis.” (disable) position.

The equipment employed in the changing of the foils consist of the control panel in the Control Room, a slosyn motor, a shaft encoder, control rod with coupling hardware to span the L.E. column and a magnetic coupling to transfer motion to the stripper foil band which resides in vacuum. Within the stripper foil housing are two bands of foils, 300 foils per band for a total complement of 600 foils. A description of the band changer can be found in Sec. 25. The foils are rotated into the beam path by the slosyn motor via a control rod spanning the L.E. column and terminating in the terminal. The 110 Vac slosyn motor is bidirectional and receives power from the Control Room via the L.E. bulkhead feedthrough BU 9, pins No. 5,6 and 7 (Increment, decrement and AC neutral respectively). The 3000 count shaft encoder is used for record keeping of the foil inventory. The encoder is coupled to the motor by a timing chain and a 10 to 1 reducing gear. The encoder signal is transmitted to a four digit counter LED display on the foil control panel via the L.E. bulkhead feedthrough BU 7, pins No. 4,5,6,7,8 and 9.

25 Terminal Foil Band Changer

The terminal band changer is actuated in the Control Room at the foil changer panel. A momentary three position switch is used along with a keyed enable switch in hopes of removing the uncertainty of knowing which band is in use and which band, if any, is exhausted. To adjust or change bands insert the key into the “Band Change Enable” slot and turn the key clockwise. The key is kept in the red box below the console. Ensure you are aware of what band is being used before making a change. Press and hold the appropriate toggle switch until beam on the HE cup drops off and then returns. Continue holding the switch and note the maximum beam current observed before the beam begins to fade again. Release the switch when the beam current begins to drop. Now fine tune the stripper foil by pressing the switch to move back towards the previous band position; release the switch when the previously observed maximum beam current returns to the HE cup. When satisfied with the band position, ensure the correct LED band indication is lit for the correct band by a short flip of the band changer switch. Turn the key counter clockwise to disable the band changer mechanism.

This paragraph describes the details of the band changer mechanism. The Foil/Band changer electrical leads run out to the L.E. Tandem base plate and then internally via the bulk head feedthrough BU 9 on pins #2, 3 and 4. Inside the machine, behind the L.E. base plate aluminum cover, is the slosyn motor that drives the control rod whenever the enable key and momentary switch in the Control Room is closed. The control rod spans the length of the L.E. column and terminates in the terminal; the control rod is on the West side of the column and is above the accelerator tube. The control rod rotates a cam/microswitch assembly in the terminal that is capable of sensing the direction of rotation of the control rod. The microswitches energize a timer/relay once per revolution of the control rod (~ 3 seconds) which in turn powers the motor that either lifts or lowers the end to the stripper foil housing for a preset interval. Movement of the stripper foils is achieved by a gimbaled pivot point on the housing allowing positioning

of the foils at the beam end of the housing. The travel or pivot arc of the housing is limited by another set of microswitches that interrupts the band changer motor power when at the end of the adjustment range.

26 Letting the Accelerator Tubes Up to Dry Nitrogen

These instructions are specifically written for letting up the minimum beamline volume to gain access to the accelerator tubes and anything between the HE fast valve and the LE Gas Security Ball Valve – typically for a foil change. Puffs of gas or excessive gas flows must be avoided to protect the fragile stripper foils in the terminal of the Tandem. If access to additional beamline length is necessary more pumps may need to be isolated and different valves closed.

1. In the Control Room turn down the lens and deflectors on the L.E. beam line.
2. Turn off the L.E. Buncher amplifier in the vault.
3. Turn power off to the L.E. and Cup 1 controllers before letting up the beam line to dry Nitrogen. Remove the lead from the L.E. cup that connects to the 300 V dc suppression battery.
4. Turn off the Low Energy and High Energy Penning gauge controllers.
5. Pump the beamline through the sputter source. Put the SNICS source in the Idle mode (consult Sec. 9 and place the exit, baffle and backing valves in the unprotected mode. Ensure the source exit valve and the others are open.
6. Close the Low Energy cryopump gate valve.
7. Close the Low Energy Gas Security Ball Valve. With the key kept under the console in the Control Room, switch the valves at the vault control panel to the unprotected position to prevent the High Energy Ball Valve from automatically closing when letting up the tubes. Additional information on the Ball Valves can be located in Sec. ??.
8. Close the H.E. fast valve to maintain a vacuum in the down stream beamline. Ensure the hand valve before the 90° magnet is open.
9. Close the High Energy cryopump valve.
10. Close the LINAC entrance valve to the North of the Tandem 90° magnet.
11. The valves and gauges necessary for letting up the tubes are at the H.E. end where the beamline exits the Tandem. A manifold with copper tubing is on the East side of the beam line. Slowly open the 1/4" ball valve exiting the manifold and in series

with the 0-50 L/min Air flow gauge so that the tubes can be let up to Nitrogen. Ensure the needle valve at the Nitrogen flow gauge is closed. The compound gauge should indicate vacuum when the valve is opened.

12. Adjust the flow gauge needle valve so that the gauge at the inlet is at 29 in. of Hg and note the flow rate; it should be about 25 L/min. Periodically adjust the flow rate to maintain that which was previously noted. The gas will need to flow for ~ 1 hour to fill the void.
13. When the tubes are at atmosphere or slightly above, close the flow gauge valve and, if necessary, slowly bleed off the excess pressure by slowly opening the pump out port 1 1/4" ball valve that is attached to the copper manifold.
14. Depending on the circumstances it may be preferable to allow a small flow of Nitrogen to reduce the quantity of air that will migrate into the tubes while they are open. Open the flow gauge slightly after the beamline vacuum seal is broken.

27 Pumping Down the Accelerator Tubes

After all the broken seals are remade the tubes are ready to be pumped out. *An oil free vacuum pumping system **must** be employed when pumping down the tubes. Do not use an oil sealed mechanical pump as they can allow oil mist to back flow into the accelerator tubes.* A Carbon Vane pump followed by a Sorption pump is sufficient. To protect the fragile foils, puffs of gas or excessive gas flows **must be avoided** so use care. Open valves slowly to begin the pumping.

1. The port for pumping down the tubes is in series with the 1 1/4" ball valve attached to the manifold at the HE beamline. Attach the pumping station to the end of the 1" copper pipe port and evacuate the pipe up to the closed 1 1/4" ball valve. Slowly begin opening this ball valve and stop as soon as either the pumping station vacuum gauge indicates a pressure rise or the vacuum pump audibly responds to a gas load. Slowly open the ball valve more as the vacuum continues to improve in the tubes. The valve should be completely open at ~ 25 in. of Hg.
2. Experience has shown that the vacuum in the trapped volume of the closed L.E. ball valve will degrade during the period the valve is closed. When the tube/beamline vacuum is at 100 millitorr open the ball valve and allow the gas load to be pumped by the Sputter Source diffusion pump.
3. Switch the gas security ball valves at the vault control panel to the protected position with the key switch. Put the key back in the red box under the console in the Control Room.
4. After the tube vacuum has dropped to 50 millitorr close the 1 1/4" manifold ball valve and open the both cryopump gate valves. Remove the pumping station and return it to where it was found.

5. Turn on the Low Energy and High Energy Penning gauge controllers.
6. Turn the L.E. and Cup 1 controllers back on and reconnect the 300 V dc suppression battery coax cable to the L.E. cup.
7. Open the HE fast valve and close the hand valve before the 90° magnet.
8. Place the SNICS source exit, baffle and backing valves back in the protected mode and close the exit valve.

TUBE VOLUME DATA

L.E. valve and H.E. Fast Valve no. 1 closed along with the associate beamline cryopump valves.

Volume for Pressure Rise Test:

Accel.Tubes:

6" inside dia., 50' long

$$(\pi 3^2) * (50 * 12) = 28.26 * 600 = 16980 \text{ cubic inches}$$

L.E. Ext.:

8" dia. and 39" long

$$50.27 * 39 = 1960 \text{ cubic inches}$$

4" dia. and 62" long

$$12.57 * 62 = 780 \text{ cubic inches}$$

H.E. Ext.:

2" dia. and 39" long

$$6.28 * 39 = 240 \text{ cubic inches}$$

6" dia. and 32" long

$$28.27 * 32 = 900 \text{ cubic inches}$$

TOTAL: 20.86 x 10³ cubic inches

Pressure Rise Data From '92:

Pressure Rise = $2 \cdot 10^{-4}$ = 0.2 microns, Time = 52 mins. = 3120 secs.

Conversion Factors: 1 cubic inch = 16.39 cc.

Volume = 339.93×10^3 -- > 340 Litres

Leak Rate = Volume * Δ Pressure/ Δ t $\sim 0.021\mu s$

28 Tandem Pressure Vessel Sulfur Hex Alarm Circuit Description

The alarm has been set to trip at 75 PSIG and is intended to safeguard the gas inventory while in the Tandem. Should a substantial (not just cold gas) change in the pressure be noted or if the panel alarm begins to annunciate immediately call a member of the staff. Not only is the SF₆ inventory expensive (\$70,000) but also is very heavy and will displace air which could possibly lead to asphyxiation. Do not linger in enclosed areas common to the gas leak. Sulfur Hexafluoride, SF₆, is, however, nontoxic.

The alarm can be muted at the front panel, but the visual LED will continue to flash as long as the pressure is below the set point value. For extended tank openings the power switch can be turned off.

The pressure and temperature transducers are mounted to the flange on the southernmost top tank port. The circuit box adjacent to the flange should be turned on and plugged into a source of 110Vac. The transducers' output is directed to the Control Room panel for display. Pressures below atmospheric are indicated by a negative sign with -14.8 psi being the lower limit of the transducers' operating range.

The tank pressure is also indicated by two Bourdon tube, mechanical pressure gauges and a Varian 501 Thermocouple gauge located at the H.E., West side of the pressure vessel. These gauges are independent of the alarm circuit. The error between the pressure indications in the Control Room with some of the others can be as high as 11%.

To reset the trip point to some other value, follow this procedure:

1. At the back of the Pressure Vessel panel is a circuit board with a toggle switch position labeled *calset*; move the switch to that position. While observing the front panel pressure indication, adjust the *cal* potentiometer until the desired pressure at which to trip is displayed.
2. Also on the circuit board is a potentiometer labeled *trip*; adjust this potentiometer until alarm sounds and the front panel LED is flashing.
3. Place the toggle switch in "1." back to the *normal* position. The panel pressure display should again indicate the current tank pressure.

29 Voltage Conditioning the Tandem

After the machine has been opened for an extended period it is often noted that the machine will not return to the previously reached voltages and run stability. Letting up the accelerator tubes to atmospheric pressure for installation of new equipment, replacement of the stripper foil supply or other work also contributes to the degradation of the voltage holding capability of the machine. Preferably, the required terminal voltage for the experiment subsequent to a tank opening will be somewhat less than those reached previous to the opening. Regardless of the voltage requested, it should be assumed that some conditioning will take place and some care should be taken when first bringing up the terminal voltage. Also, the conditioning should be carried out until a voltage of at least 250KV over the experimenter's requested voltage is attained. As the machine conditions, the required charging current to attain a specific voltage will typically decrease as corona sites on the column and other high voltage surfaces begin to dissipate allowing more current to flow through the resistance grading.

The machine should be set up to condition by first withdrawing the corona probe to the tank wall. The H.E. faraday cup should be inserted and the beam current integrator set to measure picoamperes of cup current. The integrator upper limit alarm should be adjusted to mid scale so that meter excursions will sound the alarm. The Capacitive Pick Off (CPO) trace should be displayed on an oscilloscope as well as recorded by the chart recorder. Since the machine is being conditioned the Terminal Potential Stabilizer (TPS) feedback is not necessary when charging the terminal so the Control and CPO Gains should be kept at zero. The TPS is, however, used for monitoring the Terminal Voltage and the chain charging trip feature it allows should be employed. By zeroing out the GVM error with the Terminal Reference Potentiometer, the increase in terminal potential for a fixed upcharge setting can be displayed as the "error" grows, but keep in mind the under/over protection circuit set point may be reached.

Evidence of conditioning below 6MV is not common and voltage stability problems at this potential (sparking) are indicative of greater problems and a tank opening may be necessary. In general, any voltage instabilities associated with the terminal can be considered signs of conditioning; whether or not the voltage stability improves or persists, short of a mechanical/electrical failure, determines the length of the conditioning period and its success. At higher voltages the instabilities associated with conditioning become more evident. Since the capacitive energy residing in the charged terminal and column is strongly dependent on the voltage ($CV^2/2$), more caution should be used when conditioning at higher voltages as the discharges become more destructive. When heavy conditioning begins to occur, maintain the current voltage until the conditioning events begin to subside. Voltage increases in steps of 200KV is suggested. If concern that damage is being done to the accelerator while attempting to condition (excessive sparking for example), please err on the side of caution and consult the staff.

Indications of Conditioning:

1. Voltage instabilities indicated by the CPO either at the oscilloscope or the chart recorder.
2. Current indications by the beam current integrator.
3. Fluctuations of the terminal voltage indication by the TPS that are fast and greater than 20KV.
4. Sparking of the machine, may or may not be audible, but will usually trip the under/over protection circuit. There are in general three types of sparks. Tank and Column sparks both occur in the SF₆ gas. The first is a discharge between the column and the tank wall and the other is along the column structure. Tube sparks occur within the evacuated space of the accelerator tubes and across tube electrode/insulators gaps.
5. Vacuum fluctuations at either the H.E. or L.E. end of the machine as indicated by the control room penning gauge meters.
6. Radiation emissions from the machine as indicated by the control room gamma/x-ray meter. Should these be in short bursts separated by even longer intervals and appear to be subsiding, then maintaining that voltage and waiting for improved stability is the suggested course of action. However, should the radiation persist at levels greater than 10 mREM and be steady, the machine should be turned off and the staff notified.

30 Worthington Compressor

The Worthington compressor was installed in the early '70s. It is a two stage oilless compressor with teflon piston rings and metallic reed valve assemblies. In 1995 the Dresser Rand was the current spare parts supplier (tel.1-800-634-5565). The compressor model no. is 12 1/2 X 5 X 13 HB B-2 and the serial no. is L89186. The compressor is driven by a 125 HP 3-phase motor coupled by belt and pulley. The internal connecting rod and crank do require lubrication and the recommended lubricant is ISO-VG-150; AGMA Grade 4.

The compressor is cooled with well water which is circulated through the water jacket surrounding the compressor cylinders and the heat exchanger. If the well water supply should fail the supply automatically changes over to the city water supply. The discharge from the compressor is sent to the dump well unless a valve change is made to route the water to the storm drain. The two labeled valves in the Gas Handling Room near the compressor need to be changed to allow the rerouting. After conditions return to normal and the well supply becomes available again, changes should be made to reroute the well water from dumping down the storm drain; the aforementioned valves will need to be put back in the original state. The switch from city water to well water supply is again automatic.

31 Emergency Valve Closures

If during a gas transfer the compressor should stop, a seal fail or some type of major leak of SF₆ start, it is important to safeguard the gas inventory. Also, at any time should a SF₆ loss due to a failure on the Tandem pressure vessel or the storage tank and any of the directly attached valves occur a transfer of the SF₆ inventory is suggested immediately. This, however, should not take precedent over safety as large quantities of SF₆ can displace life sustaining air. Depending on where one is in the gas transfer the compressor may or may not be running; the response depends on whether the compressor is running.

Below are the responses to three sets of circumstances that may confront the operator; some valves may or may not already be closed. The valves affected in the Gas Handling Rm. are shaded red in the preceding room layout (figure 5). After the crisis has passed and the transfer piping schematic (figure 11) is consulted a more sensible arrangement of valves may be preferred.

1. COMPRESSOR IS OFF (EQUALIZING GAS) AND A LARGE LEAK IS DETECTED

Valve (close in order)	Location
LE Tank Valve	Tandem Vault
HE Tank Valve	Tandem Vault
Valve 45	Outside atop the bottom white storage tank

2. COMPRESSOR HAS FAILED DURING THE GAS TRANSFER AND IS OFF THERE IS NO LEAK DETECTED

Valve (close in order)	Location
Valves 5 & 6	Gas handling room, orange piping on the W. floor between the back pressure regulator and compressor
Valve 20	Gas handling room, yellow piping exiting the surge tank
Valve 2	Gas handling room, orange piping on the W. floor between the back pressure regulator and compressor
LE Tank Valve	Tandem Vault, south end
Pump Pit Pneumatic Valve	Tandem Vault pump pit
HE Tank Valve	Tandem Vault, north end
Valve 40	Gas Handling Rm., south wall
Valve 41	Gas Handling Rm., south wall

3. COMPRESSOR IS ON AND A LARGE LEAK IS DETECTED

Valve (close in order)	Location
Valves 5 & 6	Gas handling room, orange piping on the W. floor between the back pressure regulator and compressor
Valve 20	Gas handling room, yellow piping exiting the surge tank
Turn the compressor off at the control panel	...
Valve 2	Gas handling room, orange piping on the W. floor between the back pressure regulator and compressor
LE Tank Valve	Tandem Vault, south end
Pump Pit Pneumatic Valve	Tandem Vault pump pit
HE Tank Valve	Tandem Vault, north end
Valve 45	Outside atop the bottom white storage tank

32 Equalizing the SF₆ Gas to the Outside Storage Vessel

(See figure 14) Time: ~ 25 minutes. Change in Pressure: 80 to 50 lbs/in².

Ensure these valves are closed before beginning the gas transfer. Refer to the locator map (figure 5) for their approximate location: 38, 39, 43, 47, 35, 36, 4, 6, 13, 46, 40

1. In the Control Room, turn off the power to the Terminal Potential Stabilizer panel and withdraw the Corona Probe.
2. In the Tandem Vault, open the H.E. Tandem gas valve at the bottom of the North end of the tank. Ensure the tank lights are turned off.
3. Open the L.E. Tandem gas ball valve at the bottom of the tank South end.
4. Open valve 41, located at the south wall of the gas handling room, to allow the gas to equalize into the Storage Vessel.
5. Open valve 29 to collect the gas left in the piping from last gas transfer. The valve will probably be open already. If gas is not heard flowing it may be that valve 3, on the East side of the Tandem is closed, open it.
6. In the Control Room, remove the control power key and place it on top of the electronic rack.

7. Switch the Gas Pressure Alarm panel to the mute mode.
8. When gas is no longer heard flowing through the piping, go to the next step.

33 Compressing the SF₆ to the Storage Vessel

(See figure 12)

Time: ~ 90 minutes. Change in Pressure: 50 lbs/in² to 23" Hg.

1. Close the two brass Hygrometer shutoff valves. One is behind the green panel at the H.E. beamline support and the other is on the H.E. Tandem end plate.
2. Close valve 41, south wall of Gas Handling Room, to route the gas from the Tandem through the compressor to the Storage Vessel.
3. Open valve 40 to allow the gas from the compressor to fill the Storage Vessel.
4. Turn on the compressor breaker switch at south-east wall in the Gas Handling Room and ensure cooling water flows through the compressor at the flow gauges located at the north end of the compressor.
5. Quickly open valve 2, orange piping on the floor by the back pressure regulator, as soon as the compressor is started. Press the start button on the breaker panel; the compressor will make quite a bit of noise when just starting. The compressor will not start with a positive input pressure. The input pressure to the compressor is indicated by the pressure gauge at the No.2 five micron filter, painted orange and West of the yellow surge tank.
6. Open valve 4 and then 5 slowly, the back pressure regulator should ensure the input pressure to the compressor does not go positive. Should a failure occur and the input pressure become positive the compressor will shut down.
7. SF₆ is fed back into a shaft isolation chamber to prevent air creeping along the shaft into the gas inventory. A pressure gauge located on the compressor, West of the No.2 filter, should indicate a slightly positive pressure (< 3 lbs/in²). Ensure this is the case.
8. After ~ 30 minutes the back pressure regulator can be bypassed to increase the compressor throughput. Don't allow the input to the compressor at the 5 micron filter to rise above 8" Hg or the heat exchanger between the two pumping stages to go over 45 lbs/in² (top gauge on compressor). The bypass is allowed by slightly opening valve 6 in steps to maintain the 8" Hg input pressure; eventually the valve will be completely opened.

9. Run the compressor until the Tandem's pressure gauge at the H.E. end registers 23" Hg (approximately -10.8 psig on the Control Room SF₆ parameter panel display). The ball valve to the right of the gauge may need to be opened. Proceed to the next section.

34 Vacuum Pump Boosting for the Compressor

1. At the H.E. end of the Tandem, connect the Varian 501 gauge controller to the thermocouple. Next to the controller, reset the Rootes Blower run time meter to zero.
2. Close the H.E. Tandem gas valve.
3. In the Gas Handling Room (figure 5), close valves 4, 5 and 6.
4. Open valve 20 slightly and ensure the surge tank pressure begins to drop. The input to the compressor must remain less than atmospheric or the compressor will shut down.
5. The procedure for starting the vacuum pumps follows; they are located below the Tandem in the pit.
 - (a) Ensure valve X2, a 1/2" ball valve between the Rootes blower and the Kinney, is closed.
 - (b) Open valve X1, located on the pit wall in the Southwest corner, to vent the stagnant air left in the piping and Rootes Blower.
 - (c) Start the mechanical pump by depressing the push button located on the panel to the left of the pumps. Hold the button down for at least 3 seconds to ensure the cooling water flow switch latches the pump run contactor. Allow the mechanical pump to run for 30 seconds then continue to the next step.
 - (d) There are two switches associated with the Rootes Blower. The upper most switch of the two is a wall type light switch that allows power to the second switch that is a three position switch. The wall light switch must be flipped up to enable the Rootes to come on. Slide the three position switch to the bottom position, manual mode; the Rootes will come on. Allow it to run for 30 seconds and then slide the three position switch to the top, SF₆ automatic mode. The Rootes will come on when the Varian 501 controller set point one is reached.
 - (e) Wait for the blower shaft to slow and then close valve X1.
 - (f) Open V10 which directs the discharge of the vacuum pumps to the compressor input.
6. Open the Tandem's pneumatic valve by turning the key at the control panel and flipping the switch located near the valve on the flexible wire conduit.

7. In the Gas Handling Room, open valve 20 the rest of the way, *yet maintain a pressure below 8" Hg at the 5 micron filter.*
8. When the Tandem pressure reaches 4.6 torr, the set point, the thermocouple controller will automatically activate the Rootes blower. If the Tandem pressure is too high the Rootes will trip its circuit breaker and must be reset behind the control panel.
9. At ~ 200 microns begin the shutoff procedure. The Control Room SF₆ parameter panel display range of sensitivity will end at approximately -14.2 psig.

35 Shutoff Procedure

1. Close the Tandem pneumatic valve in the vault pit. Use both the toggle switch and the key.
2. Turn off the Rootes Blower wall light switch and slide the 3-position switch to the manual mode, the bottom position. Allow the blower to slow.
3. Close V10 which isolates the input to the compressor.
4. Open the 1/2" yellow ball valve labeled X2 between the Rootes blower and the Kinney pump.
5. Turn off the mechanical pump by depressing the stop button.
6. Close valve X2 when air no longer flows.
7. In the Gas Handling Room (figure 5), close V20 yellow piping.
8. Quickly close V2 orange piping, after the compressor is turned off by depressing the push button. Turn the breaker to off after the valve is closed.
9. Close V40, south wall in the Gas Handling Room.
10. Disconnect the thermocouple controller from the gauge head at H.E. end of the Tandem.

36 Venting the Tandem to Air

Time: ~ 30 minutes. Change in Pressure: 150 millitorr to 1 atmosphere.

1. Turn the Tandem ports to the open position. The vacuum will keep the ports sealed shut.
2. Partially open valve 43, red piping in gas handling room (figure 5). As the flow is heard slowing, open valve 43 more. Continue until completely open.

3. After the ports are open close valve 43.
4. Place the fan in the Tandem L.E. port and turn on so that air is pulled out through the L.E. port.
5. Turn on tank lights. The Tandem is ready for floor boards and/or working inside.

37 Removing Air from the Tandem

Time: ~ 14 hours (overnight). Change in Pressure: 1 atmosphere to 25 millitorr.

1. Remove all items brought into the Tandem, wipe the terminal off with alcohol and paper towels, remove the floor boards and sweep the bottom of the tank clean. Ensure no debris is left on the Tandem pneumatic valve flapper surface inside the tank; use the ShopVac vacuum cleaner. Turn the Tandem tank lights off.
2. Shut the Tandem port doors and turn them partially closed. It will be difficult to completely close them until a vacuum is established. Make an attempt to close them at 14" Hg; typically, the lower the vacuum reached the easier it is to turn close the port doors.
3. Ensure that valves 2 and 43 in the Gas Handling Room and 10 and 11 in the Tandem pump pit are closed (See figure 5).
4. Ensure that valve X2, a 1/2" ball valve between the Rootes blower and the Kinney pump, is closed.
5. Open valve X1 to allow pumped air to exit the building.
6. Start the mechanical pump by depressing the push button located on the panel to the left of the pumps. Hold the button down for at least 3 seconds to ensure the cooling water flow switch latches the pump run contactor.
7. There are two switches associated with the Rootes Blower. The upper most switch of the two is a wall type light switch that allows power to the second switch that is a three position switch. The wall light switch must be flipped up to enable the Rootes to come on. Slide the three position switch to the middle position, air automatic mode. The Rootes will come on when the Varian 501 controller set point two is reached.
8. Open the Tandem pneumatic valve by turning the key at the control panel and flipping the switch located near the valve on the flexible wire conduit.
9. Connect the Thermocouple controller to the gauge head at the H.E. end of the Tandem.

10. Allow the Tandem to be pumped on over night to remove absorbed gases and water vapor.
11. In the morning the Tandem vacuum should be at ~ 25 millitorr. Close the pneumatic valve with the key and toggle switch. Turn off the Rootes Blower wall light switch and return the three position switch to the manual mode, slide to the bottom position. Allow the blower to slow.
12. Close X1 which allows the pumps to exhaust outside the building.
13. Open the 1/2" yellow ball valve labeled X2 between the Rootes blower and the Kinney pump.
14. Turn off the mechanical pump by depressing the stop button.
15. Close valve X2 when air no longer flows.
16. Check and top off if necessary the Rootes blower and Kinney pump oil.

38 Equalizing SF₆ into the Tandem

Time: ~ 60 min. Change in Pressure: 25 millitorr to 50 lbs/in².

1. Close the ball valve before the +30 psi -30" Hg gauge at the H.E. end of the Tandem.
2. Disconnect the Thermocouple controller lead from the gauge head.
3. Ensure valve 41, in the Gas Handling Room (figure 5) behind the yellow paint cabinet, is closed.
4. Open valve 39, red piping to the left of the grey drier/desiccant tanks.
5. Open valve 40 (next to 41) partially, especially on cold mornings to prevent thermal shock to the accelerator column. As the flow rate is heard slowing, rotate the ball valve open more.

39 Compressing SF₆ into the Tandem

~ 4 hours, 50 to 90 lbs/in².

1. Close valve 40, south wall of Gas Handling Room (figure 5).
2. Open valve 41 to route the gas from the Storage Vessel through the compressor to the Tandem.

3. Turn on the compressor breaker switch at south-east wall in the Gas Handling Room and ensure cooling water flows through the compressor at the flow gauges located at the north end of the compressor.
4. Quickly open valve 2, orange piping on the floor by the back pressure regulator, as soon as the compressor is started. Press the start button on the breaker panel; the compressor will make quite a bit of noise when first starting. The compressor will not start with a positive input pressure. The input pressure to the compressor is indicated by the pressure gauge at the No.2 five micron filter, painted orange and West of the yellow surge tank.
5. Open valve 4 and then 5 slowly to ensure the input pressure to the compressor does not go positive; this will result in the shut down of the compressor.
6. SF₆ is fed back into a shaft isolation chamber to prevent air creeping along the shaft into the gas inventory. A pressure gauge located on the compressor, West of the No.2 filter, should indicate a slightly positive pressure (<3 lbs/in²). Ensure this is the case.
7. After ~ 30 minutes the back pressure regulator can be bypassed to increase the compressors throughput capacity. Do not allow the input to the compressor at the 5 micron filter to rise above 8" Hg or the heat exchanger between the two pumping stages to go over 45 lbs/in² (top gauge on compressor). The bypass is allowed by slightly opening valve 6 in steps to maintain the 8" Hg input pressure; eventually the valve will be completely opened.
8. Run the compressor until the input pressure at the 5 micron filter registers ~ 27" Hg
9. Close valve 41.
10. Close valves 4, 5 and 6.
11. Stop the compressor and quickly close valve 2. Ensure the breaker is turned off after the valve is closed.
12. Close valve 39.
13. Close the L.E. Tandem gas valve.
14. Open the two brass Hygrometer shutoff valves. One is attached to the back of the green panel at the beamline support and the other to the H.E. Tandem end plate.
15. Turn the Gas Pressure Alarm panel back to "aural" in the Control Room. The gas transfer is complete.

40 Adding SF₆ to the Inventory from Cylinder

SF₆ is usually delivered in cylinders that come in two sizes: A and B. The cylinders are filled with liquid and their pressure will be the SF₆ vapor pressure for the cylinder temperature. Due to the latent heat of vaporization, it will be necessary to add heat to the cylinder as the liquid changes to the gaseous phase and fills the Tandem. A typical pressure encountered would be ~ 270 lbs/in². At this vapor pressure the majority of the cylinder contents can be added directly to the tandem. When all the liquid has evaporated and the cylinder pressure matches the Tandem's additional effort is necessary to empty the remaining cylinder contents. The last bit of gas can be sent to storage for recovery at the next gas transfer or the SF₆ compressor can be used to add directly to the Tandem inventory.

40.1 Adding SF₆ directly to the Tandem From Cylinders

1. Remove the cylinder caps and the plastic thread protector that often accompanies the valve. Attach the SF₆ cylinders to the flexible lines at the fill manifold in the Gas Handling Room (figure 5); the cylinder threads are left handed. Attach the cylinder heaters to the bottom of the cylinders. If plastic mesh surrounds the bottle, roll it back on itself to ensure it does not melt.
2. Open the cylinder and fill line valves. Open the valve isolating the pressure gauge at the end of the fill manifold.
3. Close valve 45 located outside on top of the storage tank. Inside the Gas Handling Room ensure they're closed or close valves 13, 2, 43, 47, 4 and 6. In the Tandem Vault ensure valve 3, on the East side of the Tandem, is closed.
4. In the Tandem Vault open the L.E. valve. In the gas handling room open valves 41, 40, 39, 29 and 46. The cylinders should now be emptying and will begin cooling down.
5. Turn on the heaters at the breaker panel around the corner from the fill station and leave them on until the cylinders either feel warm approximately 12" up from the heaters or SF₆ no longer flows from the cylinders.
6. When the cylinders' pressure has equalized with the tandem pressure, close valve 40. Continue to the next step to remove the remaining SF₆.

40.2 Removing the SF₆ remaining in the cylinders at Tandem pressure

These two procedures assume the valves are still in the state they were left in when adding the cylinder SF₆ to the Tandem. Part A describes the procedure for transferring the residual cylinder gas with the compressor to the Tandem. Part B describes the

procedure for transferring the residual cylinder gas to storage for addition to the gas inventory at the next gas transfer.

Part A, to the Tandem:

1. Turn on the compressor breaker switch at south-east wall in the Gas Handling Room (figure 5) and ensure cooling water flows through the compressor at the flow gauges located at the north end of the compressor.
2. Quickly open valve 2, orange piping on the floor by the back pressure regulator, as soon as the compressor is started. Press the start button on the breaker panel; the compressor will make quite a bit of noise when just starting. The compressor will not start with a positive input pressure. The input pressure to the compressor is indicated by the pressure gauge at the No.2 five micron filter, painted orange and West of the yellow surge tank.
3. Open valves 4 and 5 while keeping the heat exchanger below 50 lb/in². Valve 6, the regulator bypass, can be utilized yet keep the input to the compressor below atmospheric.
4. Pump on the cylinders until the compressor is at 28" Hg. Often there is a check valve installed on the cylinders that prevent a vacuum being drawn which may cause contamination of the cylinder, close valve 46 to check the cylinder pressure. Ensure the cylinders are left with little pressure by cycling valve 46 until satisfied.
5. Quickly close valve 2 orange piping, after the compressor is turned off by depressing the push button. Turn the breaker to off after the valve is closed.
6. In the Tandem Vault close the L.E. valve and open valve 3. In the Gas Handling Room close valves 4,5, 6, 41, 39, 46, fill line valves, cylinder valves and gauge valve.
7. Open valve 45 on top of the outside storage tank.
8. Return the empty cylinders to outside storage for return. Use the chains provided on the West side of the Gas Handling Room loading dock to secure the cylinders.

Part B, To storage:

1. In the Tandem Vault close the L.E. valve. In the gas handling room close valves 41 and 39.
2. Open valve 45 on top of the storage tank outside.
3. Back in the Gas Handling Room, open valve 41 to allow the SF₆ to flow to the storage tank. Often there is a check valve installed on the cylinders that prevents a vacuum being drawn which may cause contamination of the cylinder, close valve 46 to check the cylinder pressure. Ensure the cylinders are left with little pressure by cycling valve 46 until satisfied with the cylinder residual.

4. After the cylinders are emptied close the individual cylinder and manifold valves. Close valve 41.
5. In the Tandem Vault open valve 3.
6. Return the empty cylinders to outside storage for return. Use the chains provided on the West side of the Gas Handling Room loading dock to secure the cylinders. A call to the supplier of the SF₆ will hasten the cylinder collection.

41 SF₆ Gas Drying

The three major components of the gas drying system are the blower, desiccant tanks and hygrometer. SF₆ from the accelerator is removed at the L.E. valve passed through the dryer circuit and then returned through the H.E. valve via the blower. The desiccant beds will remove water from the gas as it is continuously cycled until a sufficiently low dew point or water vapor content is reached, ~ 10 ppm. The desiccant in the tanks does, however, adsorb a finite amount of water and will require reactivating when it has become saturated. The desiccant is reactivated by passing hot air through the tank evaporating the water that was removed from the SF₆.

Reactivating the Gas Dryer

1. Ensure valves 35, 37 and 47 are closed.
2. Inspect the pressure gauges atop the silver/grey desiccant tanks. If they are pressurized slowly open valve X-3 to release the pressure.
3. After the tank pressure is released, open valve X-4 and turn on the power at the red electronics box to the north of the desiccant tanks. A blower should come on along with the heater elements; the red light atop the electronics box should be illuminated.
4. Allow the reactivation cycle to continue; it will automatically shut off when the desiccant tank temperature reaches the thermostat set point, ~ 3 hours.
5. Close the two valves X -3 and -4, and turn off the switch at the electronics box. Allow the desiccant tanks to cool to room temperature before attempting to dry the SF₆.

Recirculating the Gas

This procedure assumes the Tandem has been secured in the normal fashion after being gassed-up and the dryer has been reactivated.

1. Ensure valves 35 (blue piping Gas Handling Room, figure 5), 29 (red piping Gas Handling Room), 3 (orange piping east side of Tandem), X-3 and X-4 (gray piping gas handling room) are CLOSED.

2. Open valves 36, 37, 47 (blue piping gas handling room), the L.E. Tandem valve and H.E. Tandem valve.
3. The power switch for the blower used to recirculate the SF₆ through the desiccant tanks is located at the fuse box to the left of the entrance to the Tandem Vault L.E. end labeled Recirculator. Three push buttons are located at the bottom of box, also, a grey extension cord should be hanging from the bottom, plug the cord into one of the outlets immediately to the right. Depress the start button to turn on the blower in the blue tank in the north east corner of the Gas Handling Room.
4. Allow the gas to recirculate through the dryer circuit until the hygrometer indicates a dew point or water vapor concentration that is acceptable (below -50°F)
5. Turn off the blower and close valves 36, 37, 47, the L.E. Tandem valve and H.E. Tandem valve.
6. Ensure that valves 3 and 29 are left open.

42 SF₆ Leak Checking Gun

When ever a SF₆ leak is suspected, or when making routine checks after gas transfers the SF₆ leak detector or leak checking gun can be used to localize small, inaudible leaks as small as 0.2 cc/sec. Normally the gun is kept in the gray Tandem Cabinet in the NW corner of the control room. Detailed instructions concerning the gun are included in the black carrying case. A general description for setting the detector up follow and are included in the carrying case.

1. Ensure there is at least 150 lbs. of argon pressure in the cylinder. Open the cylinder valve to check this.
2. On the gun, turn the selector switch to the *check volts* position and squeeze the guns trigger; the meter should indicate between 60-80 divisions unless the batteries need replacing.
3. The Detector will require a purge period of five minutes or so. Press the *check detector* button while simultaneously squeezing the trigger; the meter should indicate 0 before the purge and 40 or more divisions afterwards. It does not some maintenance of the gun is in order.
4. Turn the selector switch to the appropriate sensitivity and adjust the zero. Normally I adjust it to zero while at the highest sensitivity in the Control Room. The zero setting will be altered some as the detector cell cleans up.
5. Check the pressure vessel for leaks by bringing the gun barrel or tip into close proximity to areas suspected of leaking SF₆.

6. Ensure the cylinder is turned off before putting the leak checking gun in the carrying case and back into the gray cabinet.

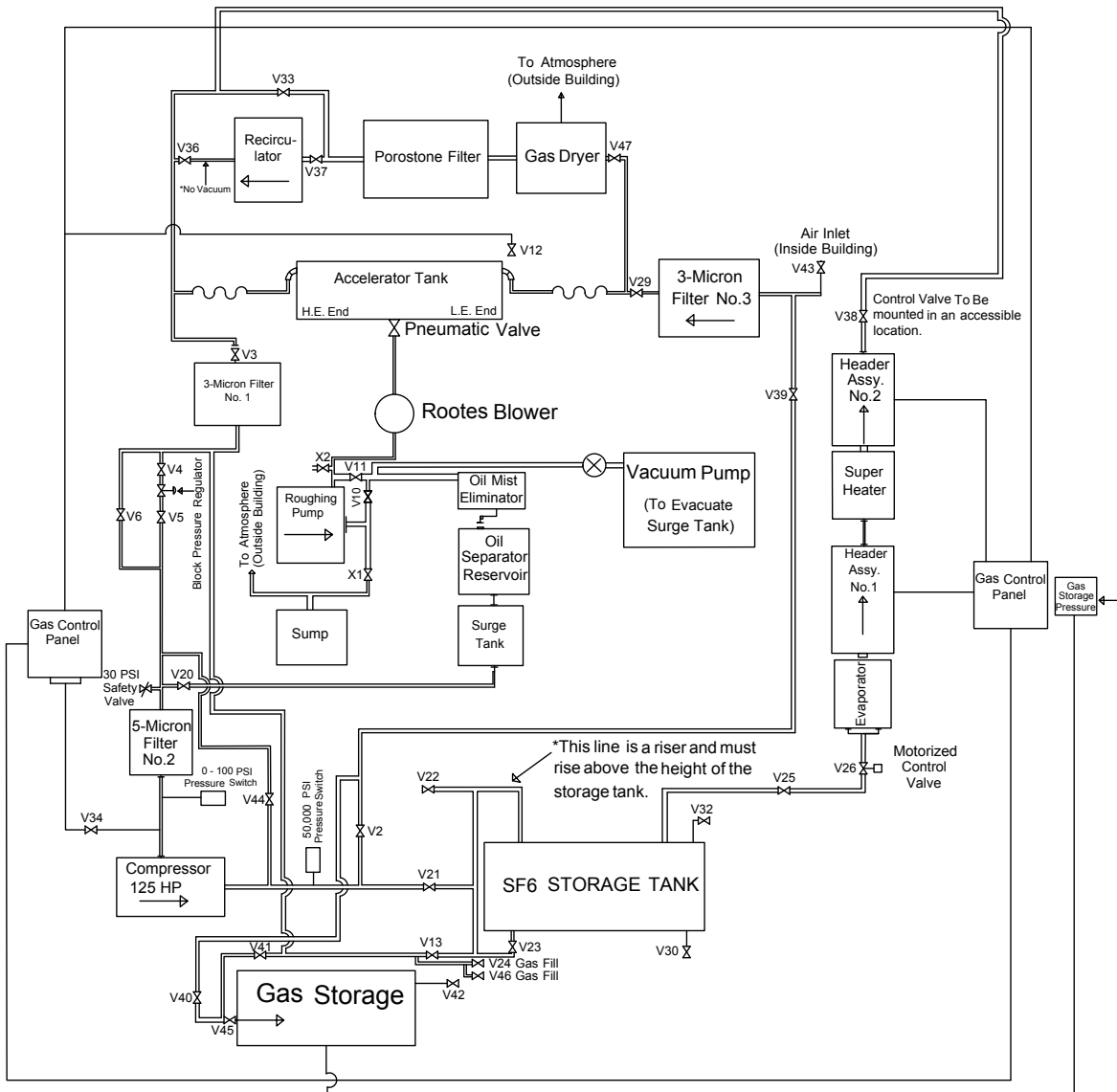
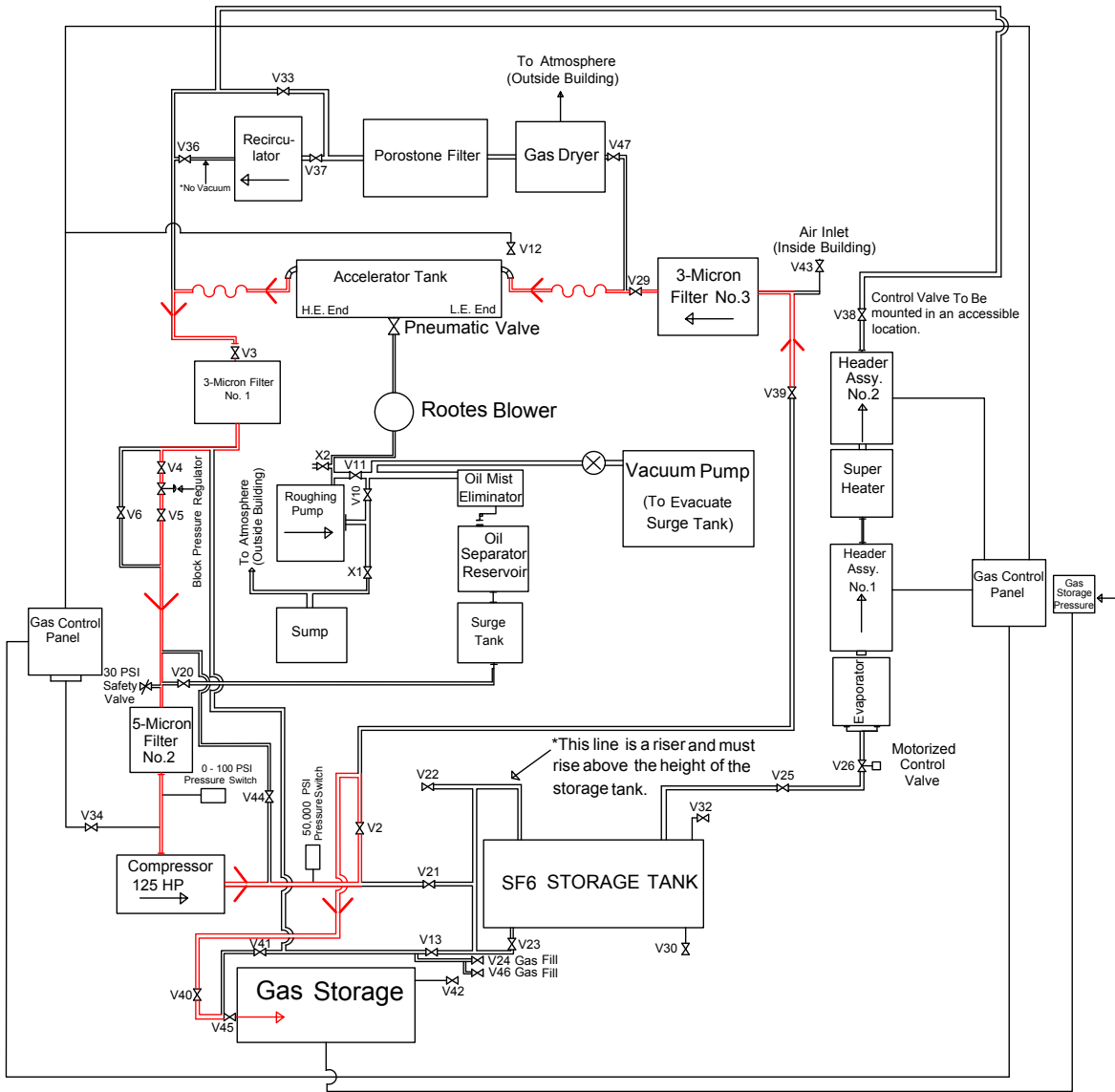
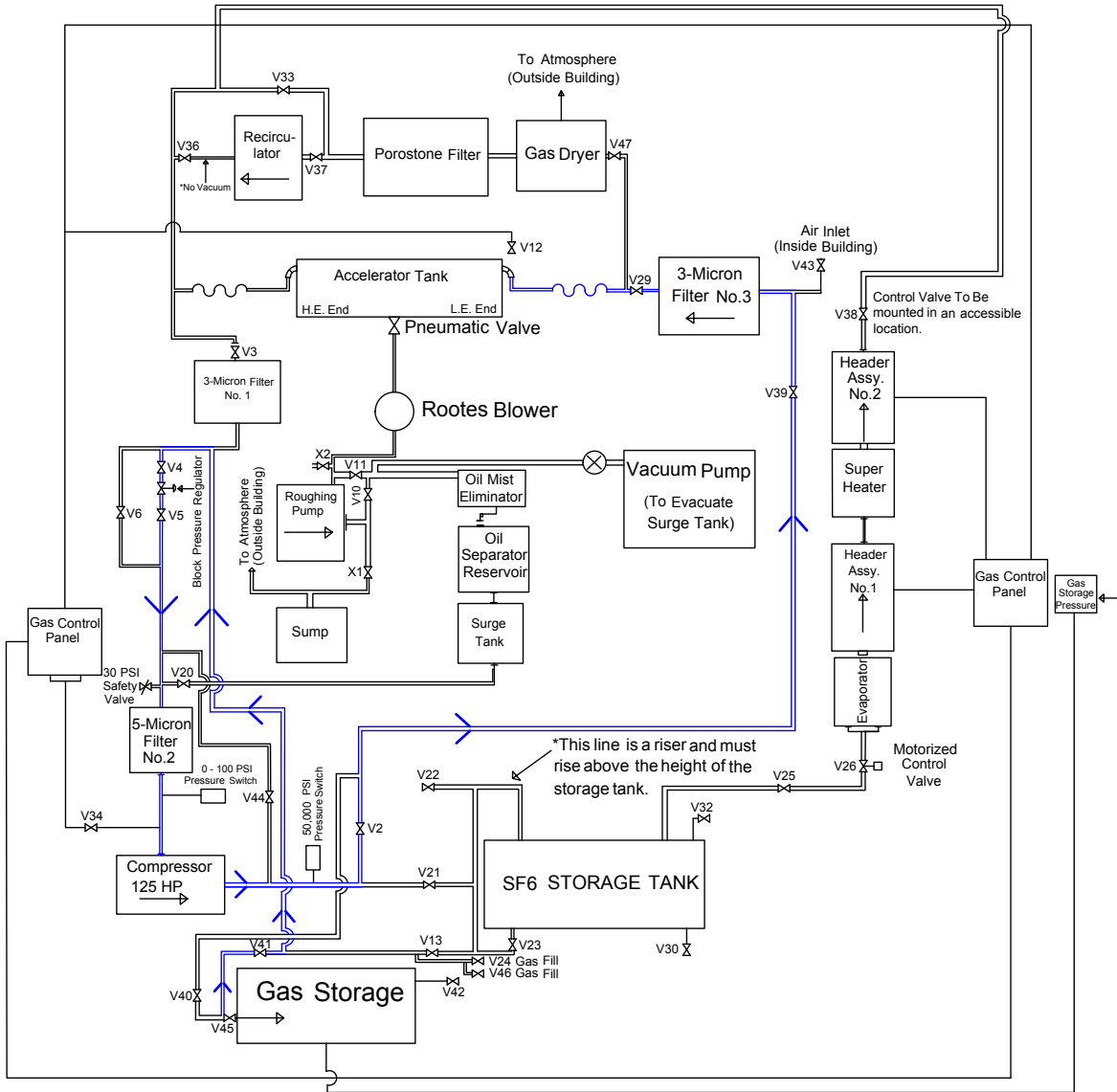

Figure 11: Piping for SF₆ Gas



COMPRESSING SF6 TO STORAGE

Figure 12: SF₆ Compress to Storage



COMPRESSING SF6 FROM STORAGE

Figure 13: SF₆ Compress from Storage

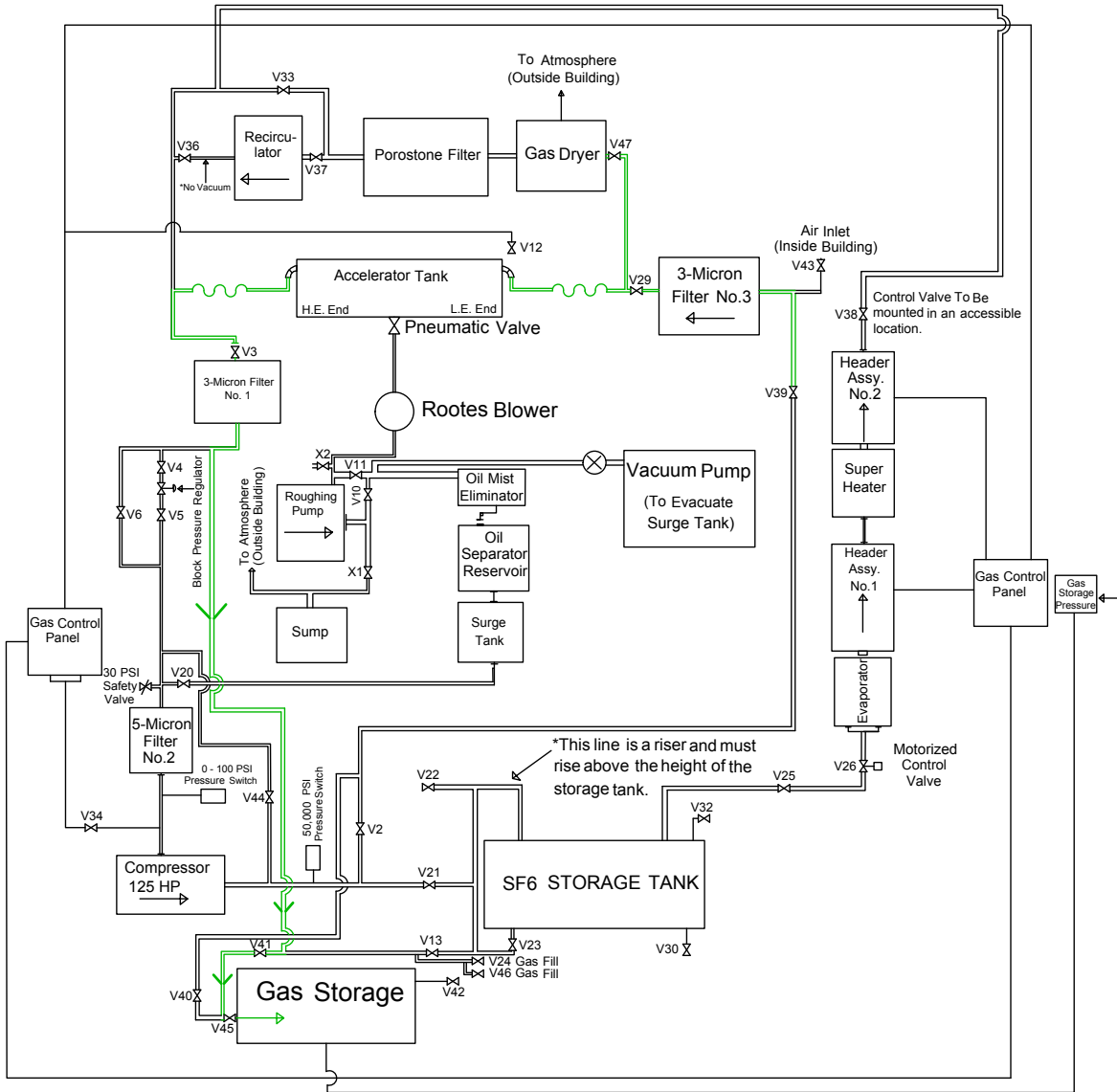

EQUALIZING SF6 TO STORAGE

Figure 14: SF₆ Equalizing to Storage

43 LINAC Operating Instructions

43.1 Power Outage Procedure

When the building power is interrupted the Helium liquefier will stop along with its associated compressors. After this happens the linac boil off will begin to vent through a 1" pressure relief valve located behind the liquefiers. Do not be alarmed by this as it is designed to operate in this manner.

The linac chart recorder auto dialer will activate and someone on the linac list will be "beeped". He will usually call the lab on the 644-6763 line before coming in. If no one calls within 15 minutes, call someone of the call list (see notice by phone in the control room).

Of the following procedure, item 1 should be done immediately after the emergency power comes on. Items 2 and 3 within 30 minutes or so, items 5 and 6 only if necessary.

1. Open vacuum valves between the cryostats by switching the valve controllers FV5 thru FV8 to the manual open position. This allows the entire linac to be pumped by the turbomolecular and rotary pumps which are on emergency power.
2. Make sure the turbo pumps on the buncher, cryostats B, C and D and the re-buncher have restarted. If not follow procedure posted by each pumping stations electronics rack.
3. Close the J. T. valve on the liquefier (this is the micrometer handled valve) a fraction of a turn clockwise until you feel resistance.
4. Now wait and monitor:
 - (a) Pressures: 1K dewar, linac and compressor return.
 - (b) Vacuums in all cryostats.
 - (c) LN₂ and LHe levels in the 1K dewar and cryostats.
 - (d) Resonator and solenoid temperatures.

As each cryostat runs out of LHe and its resonators (and solenoids) start to warm up:

5. Pump the helium out of the slow tuners.
6. Run down the persistent currents in the solenoids.

43.2 Restart Procedure

1. Turn on the load 2 RS compressors (look in the log book for information on which 2 were being used) using compressor start buttons on the liquefier.

2. Defrost o-rings on relief valves as required.
3. Start the appropriate liquefier:
 - (a) Push the liquefier start button.
 - (b) Turn the flywheel c.c.w. until the machine starts to run.
4. Open the J. T. valve to 0.085.
5. Return FV5 thru FV8 to auto position.
6. Restart the turbopumps just upstream from the 90° magnet and on the switching magnet (note: before starting the turbopumps, make sure the foreline pumps are running and the ball valves to the turbos have been re-opened with foreline vacuum < 50 m.)

Super Fast Valve Reset Procedure:

The super fast valve operates with the spark-gap vacuum protection system on the beamlines to the various experimental stations. If vacuum is lost downstream of the switching magnet this valve will quickly close to prevent vacuum loss in the Linac cryostats. Once this valve has fired it must be “rearmed” using the following procedure:

1. Switch the S.F.V. controller (located in the vacuum protection rack) to disarmed.
2. Disconnect the cable from the back panel of the controller labeled to valve.
3. Using a 7/64 allen wrench loosen the two hex head bolts that attach the trigger mechanism to the top of the valve body.
4. Using a pair of vise-grips remove the spent squib from the trigger device and replace it with a new one from the can located on switching magnet.
5. Make sure there is good contact between the pin on the squib and the connector on the cable from the controller.
6. Hook up the air line (nylon tubing with nu-pro valve next to the valve) to the swagelok fitting on the side of the valve body and open the nupro valve. The valve stem should emerge from the hole in the top of the valve body after this occurs, close the nupro valve and remove the air line.
7. Hook up the cable on the controller marked “to valve” again and then switch the control unit to the “Test” position. Push the reset button and then switch the controller to the armed position.

43.3 Troubleshooting Linac out of Lock Problems

If the L.E. Bunching system and the Linac resonators are ‘in-lock’, the % in-lock meter in the control room should read 100%.

If the reading is zero or unsteady, the following should be checked:

1. Is the L.E. buncher phase lock O.K.? see 43.3.1.
2. Are any of the resonators “out of lock”? See 43.3.2.
3. If several resonators are simultaneously out of lock (their LED’s on the resonator display panel are flickering), one or more cryostats are probably filling with the LN₂.

Go to the LINAC Hall and check the status of the “fill” indicator lights on the LN₂ controllers which are located on the instrumentation racks hanging from the blue radiation shield wall. If one or more of these indicator lights is illuminated, you will have to wait for all of them to stop filling before further diagnosis can be made.

43.3.1 Troubleshooting Loss of Beam Phase Lock

Look at the oscilloscope labeled “PHASE LOCK STATUS” in the LINAC electronics rack in the control room. If operating properly there should be a trace – the beam phase error signal – 1 division above ground, at the position marked ‘buncher’ on the scope. If this trace is a straight line at zero, or the top of the screen, or is very jumpy, the beam phase lock is not working properly. Check the following:

- Is there beam going through the phase detector, that is, is there beam on BS-2? See 2.
- Is the L.E. buncher “PHASE LOCK” phase set properly? See 3.
- Is the chopper phase set properly? See 4.

1. Buncher and Chopper Background Information

The d.c. beam from the ion source is bunched into a series of pulses, about 1 ns long and 20.6 ns apart by a gridded buncher at the L.E. end of the tandem, see figures 15 (a) and 1. The residual beam, about 50% of the total, between pulses, is swept away by a parallel plate chopper at the H.E. end of the tandem, see figures 15 (b) and 1. Because the beam pulses entering the LINAC must be precisely synchronized with the R.F. in the LINAC resonators, the L.E. buncher and chopper are both actively phase locked to the LINAC 97 MHz master oscillator.

The chopper R.F. is phase locked to the M.O directly. However, this would be insufficient for the L.E. buncher because the transit time of the beam pulses from the L.E. buncher to the LINAC is sensitive to the ion source pre-acceleration

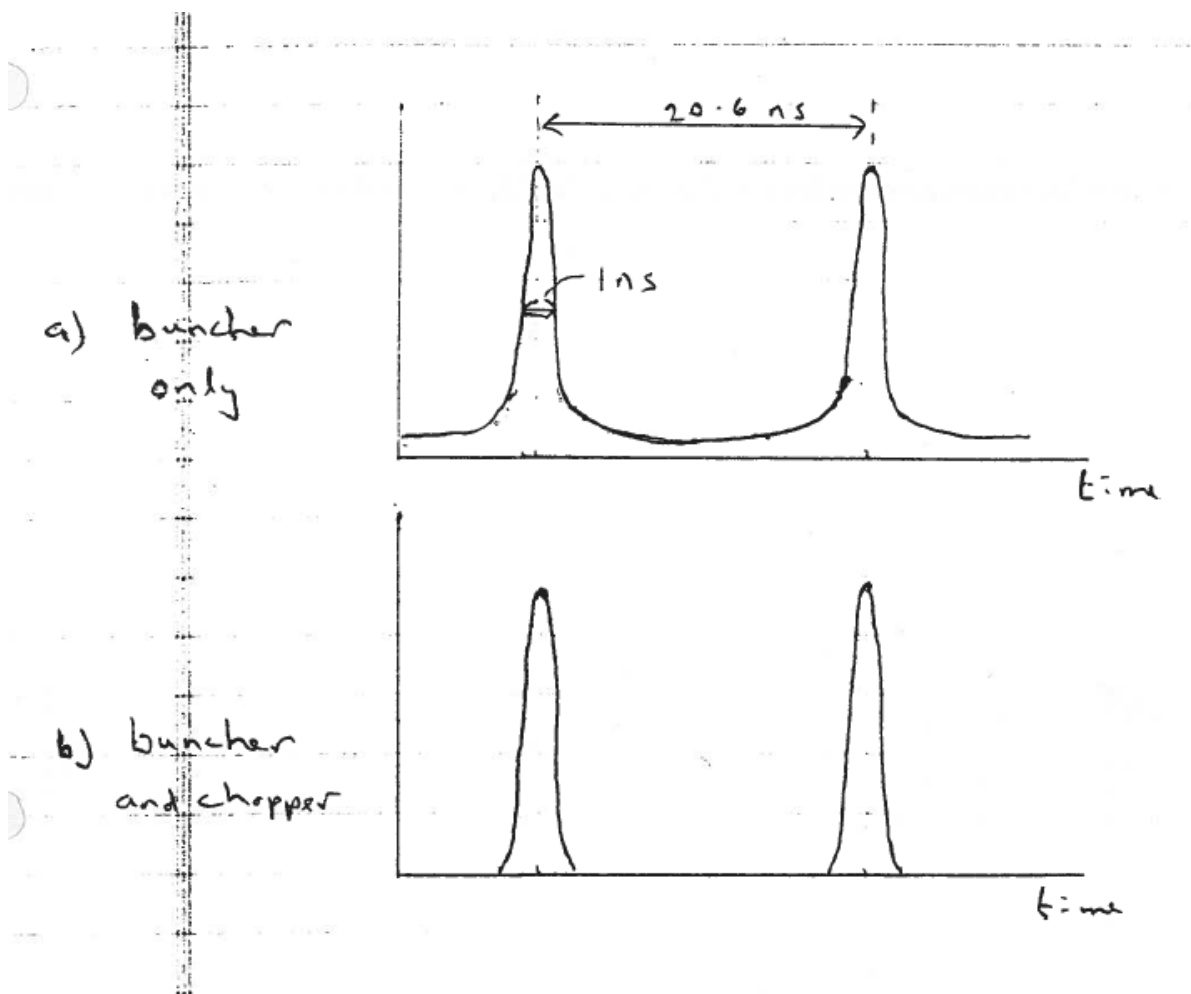

Figure 15: Time structure of the pulsed beam from the Tandem

voltage and to the condition of the tandem. Instead, the phase of the L.E. buncher is continuously varied to keep constant the time of arrival (or phase) of the beam pulses at the beam phase detector – this is located just after the LINAC 90° magnet, see figure 1.

The “beam phase error signal” is generated by mixing the master oscillator and the R.F. signal from the beam phase detector in a double balanced mixer (DBM), see figure 16. This signal is amplified, and (with the proper sign) used to vary the voltage controlled phased shifter which varies the phase of the L.E. buncher. It is, of course, a measure of the beam phase error, and is displayed on a scope. The “beam phase error” signal is also monitored by a unit called the “pulser range alarm” which has upper and lower voltage setpoints. If the phase error signal goes outside these set points, the unit will generate an out of lock signal and zero the % in-lock meter.

The buncher phase lock system, on its own, works quite reliably. Unfortunately, the chopper, being located before the phase detector, makes the overall behavior more complicated. If for any reason, the beam pulses do become mis-phased by more than a ns or so, they are swept-away by the chopper and do not reach the phase detector. In this case, the phase detector still sees “pulses”, but of residual beam, generated by the chopper instead. A spurious phase error signal is generated and the beam phase lock system may hang up.

To overcome this the “pulser range alarm” unit, when it goes into out-of-lock mode, temporarily disables the feedback control of the L.E. buncher phase, and resets the L.E. buncher phase to that corresponding to zero phase error. In most cases this automatically unhangs the system and allows the feedback system to lock up again. The chopper phase lock system uses an R.F. pick-up signal from the chopper itself and is independent of the beam; see figure 17

2. Check beam current on BS-2

Temporarily disconnect the chopper drive cable – the cable from the output of the “chopper stabilizer” unit to the patch panel “To 24 MHz CHOPPER” at the patch panel. Insert BS-2 and check the current. If the beam has fallen off considerably – (you should know what it is supposed to be!) – you must get the current back before proceeding. Investigate:

- Source output: Insert the L.E. cup.
- Transmission through the tandem, has the foil gone bad? Insert C-1.

If the beam on BS-2 is O.K. with the chopper off, but is greatly reduced when the chopper is reconnected, check the phasing of the buncher and chopper, see 3 and 4.

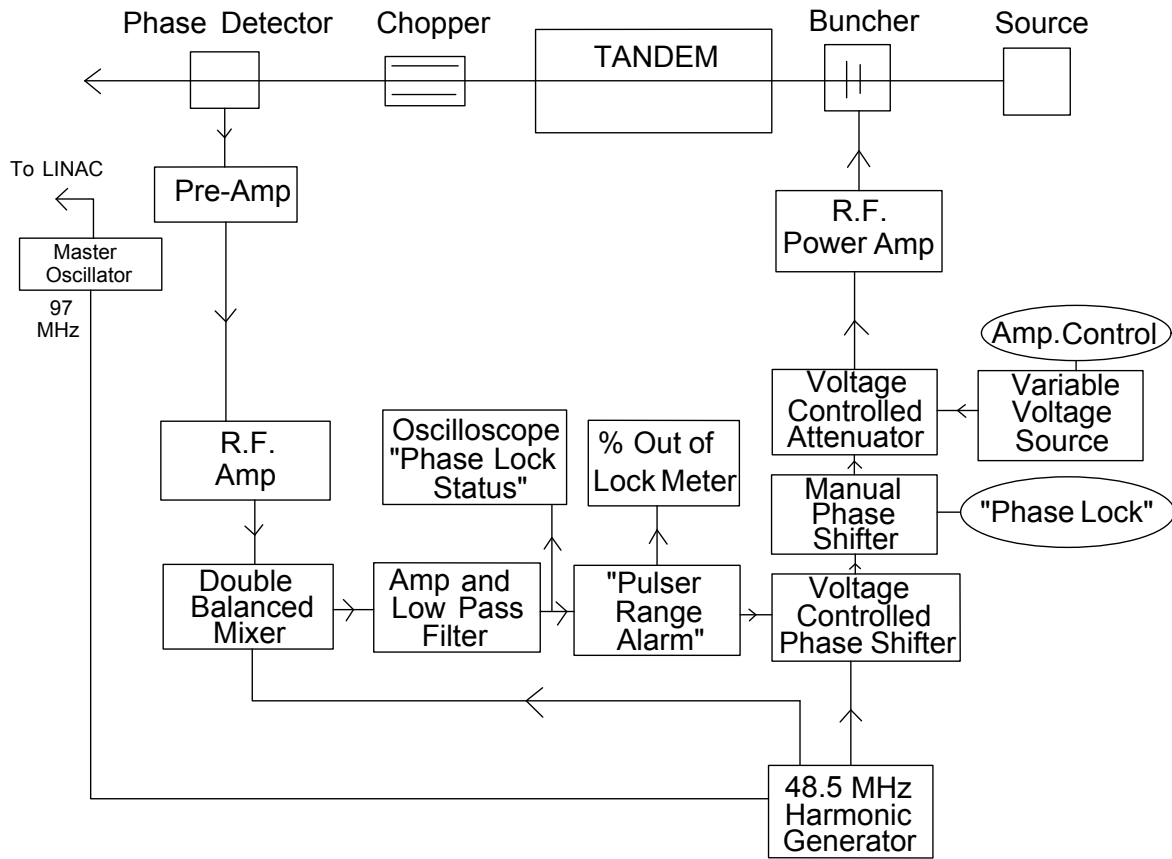

Figure 16: Simplified schematic of beam phase lock system.

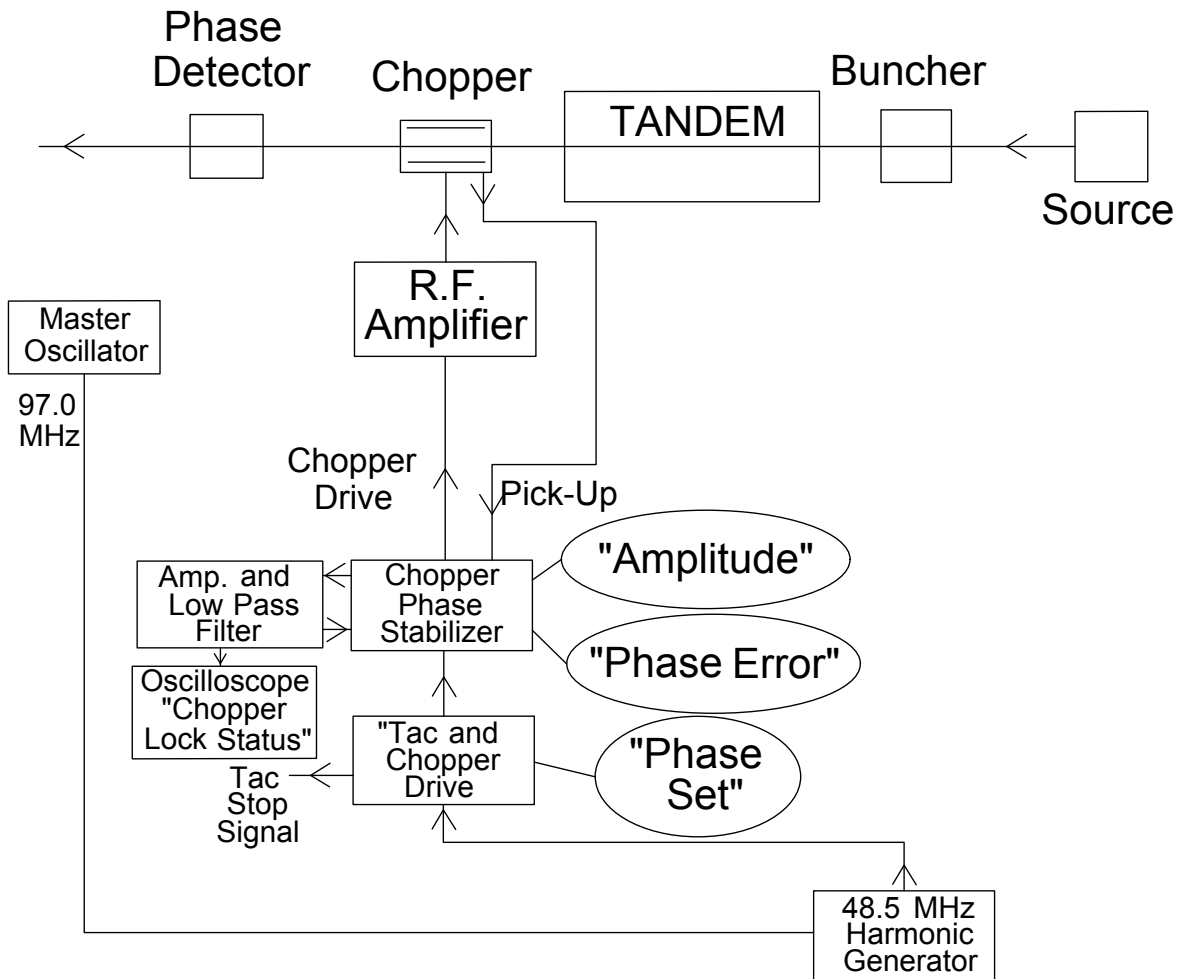

Figure 17: Simplified schematic of chopper phase and amplitude control system.

3. Adjusting the L.E. buncher “PHASE LOCK”

Temporarily disconnect the chopper drive cable to disable the chopper (see 2). The beam phase error signal on the “PHASE LOCK STATUS” scope should be 1 division above ground. If it is not, adjust the “PHASE LOCK” knob on the electronics rack to bring the trace to the correct position. When properly set the trace should move upwards as the knob is rotated clockwise.

If you are unable to get a reasonably steady trace (it should have slight line frequency wiggle on it) then:

- There is something else wrong with the L.E. buncher system. See 5 or get help.
- or, more likely, the tandem and/or ion source are unstable.

If the correct phase error signal is seen, next recheck the chopper phasing, see next section, 4.

4. Setting Chopper PHASE

With the beam on BS-2 and the L.E. buncher properly set (i.e. the beam phase error signal is 1 division above zero), reconnect the chopper drive cable. Ideally the beam on BS-2 should fall by about 50%. If reconnecting the chopper causes the current on BS-2 to fall by more than 50%, adjust the PHASE SET knob on the “TAC AND CHOPPER DRIVE” until the beam on BS-2 is maximized and is nearly 50% of the unchopped beam, and also, the beam phase error signal is properly located 1 division above zero. Note that readjustment of the beam “PHASE LOCK” knob is sometimes required.

If you are unable to achieve a stable beam phase lock with the chopper on, it usually means that the ion source and tandem are too unstable for the phase lock system to keep the beam pulses going through the time window set by the chopper. If time and energy resolution are of no concern, the system can be made more stable by reducing the chopper amplitude, see 7. You should also check the chopper phase lock, see 6.

5. Check the L.E. Buncher Field Level

Use the LINAC oscilloscope, channel 1, 50 Ω , to kook at the “48.5 MHz buncher

pick-up” on the patch panel in the control room. Leave the 20dB attenuator in place. The peak-to-peak voltage should agree with the value recorded in the log book during run set up, as the optimum L.E. buncher setting.

If the pick-up signal is much lower (a few percent is not significant) there is a problem with the L.E. buncher system.

6. Check Chopper Phase Lock

(The chopper is phase locked directly to the master oscillator. The system is independent of the beam, and so in general does not need adjustment.) When the chopper is connected, the “chopper phase lock” trace, the lower trace on the “PHASE LOCK STATUS” scope, should be at 2.5 divisions below zero. If it is way off, the chopper R.F. amplifier is off, or a cable has probably not been connected properly. If the trace is slightly displaced from its set point, adjust the “PHASE ERROR” knob on the “chopper stabilizer” to bring the trace back to 2.5 divisions below zero.

7. Adjustment of Chopper Amplitude

The amplitude of the R.F. electric field in the chopper can be adjusted using the knob on the “chopper stabilizer” unit labeled amplitude. Reducing the amplitude makes the chopping looser. This usually makes the buncher “phase lock” system more stable, but worsens the energy and time resolution of the LIONAC beam.

Make sure you note the old and new chopper amplitude settings.

43.3.2 Resonator Lock Status

If one of the Linac resonators goes ‘out of lock’, its associated light on the resonator status display will illuminate. The control electronics for a resonator will generate an O/L indication if the error signals in the feedback loops used to control the resonator field level or phase are excessive. After identifying the problem resonator go to the Linac hall and check the following:

- Is the cryostat filling with LN₂?
- Is the pin diode pulser (P.D.P.) tripped? See 1 below.
- Is the resonator phase lock and field level correct? See 2 below.
- Does the R.F. amplifier have power?

To check the status of the amplifier do not depend on the indicator light, instead look for meter indication or feel behind the unit for operation of the fan.

1. Checking the Pin Diode Pulsar (P.D.P.) for proper operation.

P.D.P. tripped on overcurrent:

First check the P.D.P. overcurrent indicator (figure 18) for the out-of-lock resonator. If illuminated push and release the red reset button on the front of the unit. This will reset the interlock and should restore the P.D.P. to normal operation. If the P.D.P. will not reset after a few attempts or continues to trip frequently call someone on the Linac call list for assistance.

Checking the P.D.P. for correct operational:

If the P.D.P. is not tripped the current and voltage output can be checked. First turn off the R.F. amplifier then switch the P.D.P. to the 'off' position. 500V should be indicated and 0 current. Next switch to the 'Auto' position. There should be approximately 1A current and 0V indicated. If either of the above readings are not observed call someone on the Linac call list for help. Finally, note the present setting of the VCX gain knob on the S.T.C. then set it to minimum. You should see a clean square wave with a slight sloping top. If not, get help. Reset the VCX gain knob.

2. Checking for proper phase lock and field level

Use the Tektronics 2445A dedicated Linac scope and select the recall 3 program option. The scope should be set up as follows figure 18 A and B. The time base should be set to 20 μ sec. CH.1 is connected to the can mon. (100mV/div./50 Ω) CH.2 is connected to the P.D.P. mon. (500mV/div./1M) CH.3 is connected to the phase error (0.1V/div.) CH.4 is connected to the P.W. clockout (0.1V/div.) trigger the scope on CH.4. For a normally operating resonator the trace illustrated in figure 19 should be observed. After setting up the scope check the following:

- First check that the resonator is operating at the proper field level. The peak-to-peak amplitude of the can mon. signal on the scope should match (± 20 mV) the LEV SET value for that resonator on the Linac control screen. Look at the monitor near the cryostat C. If the can mon. is less than the LEV SET the resonator is 'normal', multipactoring or the self excited loop phase control is misadjusted, see a and b.
- If the field level is O.K. focus on the P.D.P. monitor and phase error signals.
 - If the P.D.P. monitor signal shows no resemblance to a square wave (figure 19) (even a 'smeared' out one), i.e. the trace is a line at 0V or near 1V, the P.D.P. is not switching. See 1.

- If the P.D.P. is switching, but smeared out, and the phase error signal (figure 19) is smeared out, or is jumping over most of the screen, the resonator is totally out of phase lock -i.e. the resonator frequency does not match the master oscillator frequency, see c.
- If the phase error signal and the P.D.P. monitor signal (figure 19) are recognizable as a sawtooth and square wave respectively, but are asymmetric and jittering, the fast tuner system (P.D.P.-VCX) is not operating about the center of the range. If this is the case the slow tuner driver center frequency pot (figure 18 C) has to be adjusted. See (d) below.

(a) Resonator Normal or Multipactoring

If the resonator has gone normal (i.e. no longer superconducting) the can monitor signal which is usually 300 – 600 mV peak-to-peak will be 0 or very small. If this is the case turn off the R.F. amplifier and wait 5 min. then turn it back on. The resonator should re-excite after a few seconds. If it does not, try adjusting the PHASE knob (the self excited loop phase) on the front of the R.F.C. see b. If this fails (and the R.F. amplifier has power) the resonator is probably multipactoring and needs conditioning. Call for assistance.

(b) Resonator self-excited loop phase adjustment for proper field level

If the can mon. signal is 0 or very small it may be due to a misadjustment of the resonator self-excited loop phase. To investigate this possibility first turn off the auto-start circuit (a small toggle switch) located on the back of the S.T.C. and adjust the phase control on the front of the R.F.C. If the resonator excites, carefully adjust the phase to maximize the peak-to-peak amplitude of the can monitor signal. Turn autostart back on at the end.

(c) Resonator operating at the wrong frequency

Use a frequency meter to check the frequency of the master oscillator. This is done by attaching the freq. Meter to the can mon. of a properly operating resonator in the same cryostat. Make a note of this value. Next look at the problem resonator's frequency using its can mon. If this value is not the same note the present setting of the slow tuner driver gain (figure 18 C) then turn it down to its minimum setting. Next adjust the "center frequency" pot until the resonator's frequency is within 20 Hz of the master oscillator. Turn the gain back to its previous value. The resonator should lock up within a minute or two. Finally adjust the slow tuner driver center freq. Pot. For a proper operation as described in (d). If the P.D.P. cannot be centered, or out-of-lock is still indicated, call someone on the Linac call list for help.

(d) Adjustment of the slow tuner center freq. Pot. For proper phase lock

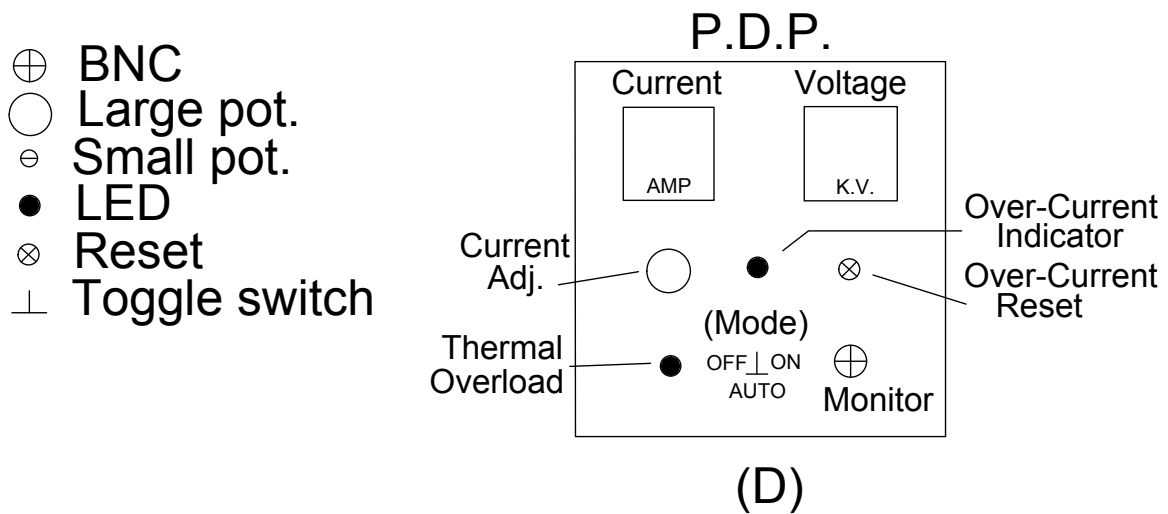
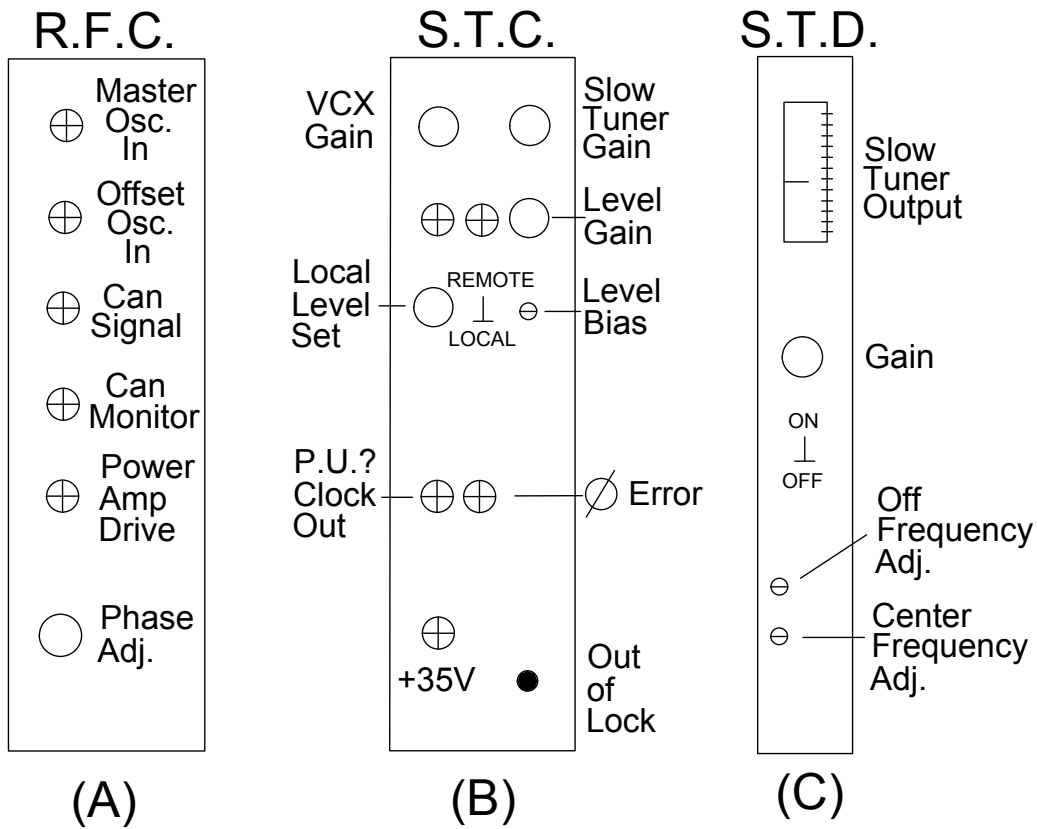

Figure 18: Indicators for Resonator Lock Status

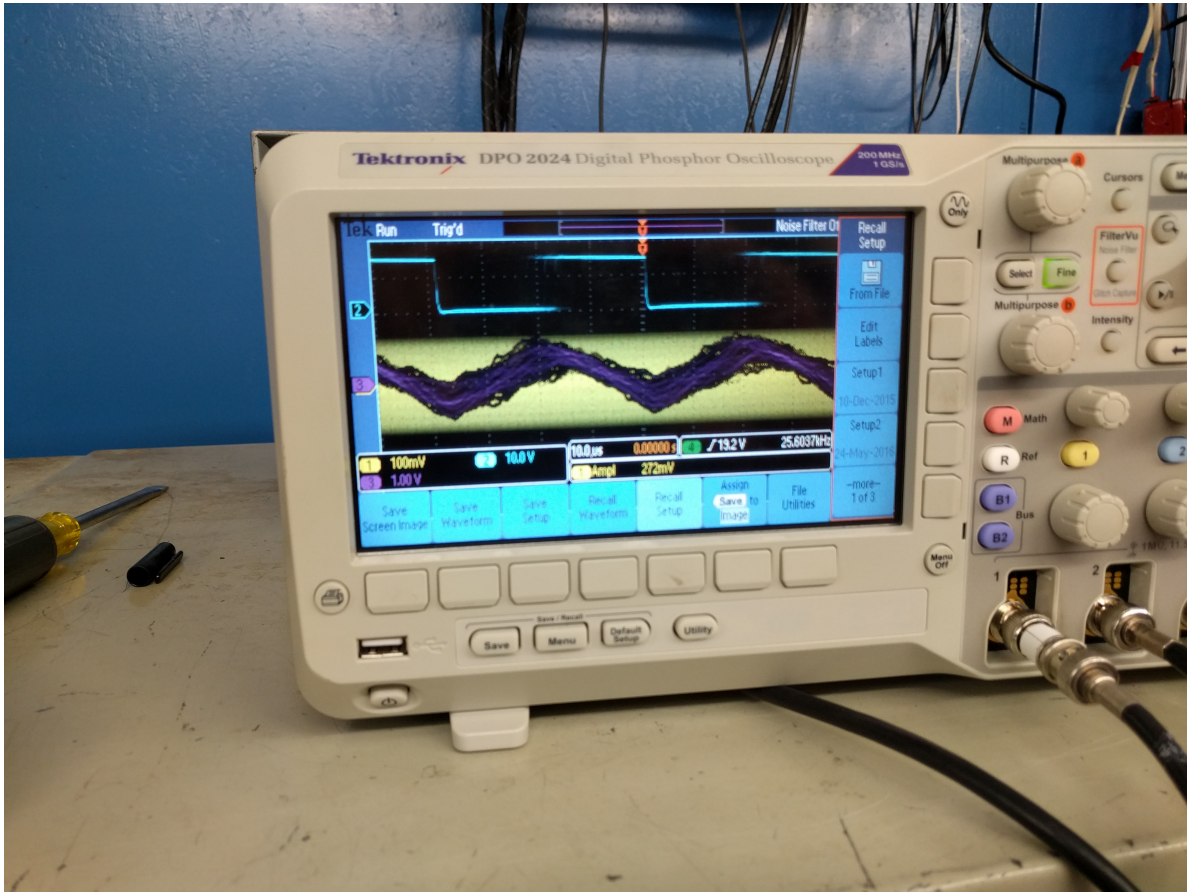

Figure 19: Scope Lock Status for Resonators

The P.D.P. should be operating in the center of its ‘window’ for proper phase lock. If this is off-center the amount of heat to the slow tuner must be adjusted using the ‘Center Frequency’ adjustment pot (figure 18 C) on the front of the slow tuner driver. Use a small screwdriver (do not push!) and slowly tweak the Center Frequency pot. until the P.D.P. monitor signal is an approximate symmetrical square wave.

43.4 The Linac Energy/Timing Chamber

Background see 43.4.1

To insert target into beam see 43.4.2

To measure beam energy see 43.4.3

To measure beam timing see 43.4.4

43.4.1 Background

The so called energy monitor chamber (E. MON) is located downstream of cryostat D and is used to measure the energy of the boosted beam. It is also used (usually with the linac resonators off) to measure the time spectrum of the pulsed beam from the L.E. buncher and chopper. The beam passes through a thin gold foil and a tiny fraction is scattered onto a surface barrier detector placed at about 30° to the beam direction. The detector preamplifier generates separate timing and energy signals which are sent to the control room.

The timing signal is used to start a Time to Amplitude Converter (TAC) which is stopped by 97/8 MHz pulse train derived from the linac master oscillator via the “TAC AND CHOPPER DRIVE” unit. The output of the TAC can be directed to the LINAC MCA to give a spectrum of the time of arrival of the ions at the E. MON detector relative to the master oscillator.

The energy signal is processed by a Spectroscopy Amplifier and can be directed to the LINAC MCA to give an energy spectrum of the beam. An energy calibration is obtained (usually during Linac setup) by determining the channel number of the energy centroid of the tandem only beam. For the second point, we simply assume that channel 0 corresponds to 0 MeV. Figure 17 shows a simplified schematic diagram of the chopper phase and amplitude control system.

43.4.2 Insertion of Target into Beam

The monitor chamber has a collimator and a target wheel, mounted on a common axle. Pressing the forward/reverse control button steps the wheels one position. The wheels have 16 positions but foils and collimators are usually only loaded in 3 positions. The collimators have different sizes, to enable some control of the count rate. The ‘home’ position is a 1 inch hole in both wheels.

Before inserting a foil, first optimize beam current on cup-5 with the monitor in the ‘home’ position. Next insert a foil (and collimator); for most beams the medium collimator is good. To accomplish this, increment the wheel 6 steps forward by pressing the “Energy Monitor” FRWD button on the beam devices display/control panel 6 times. You must wait for the FRWD LED to go out between each step. If it is required to increase or decrease the count rate, select the small or large collimators at positions 8 and 10 steps from ‘home ’ respectively.

After inserting the foil and collimator combination it is usually necessary to use deflector D-3 to steer beam through them, and onto cup-5. A few nA of transmitted beam on cup-5 is good.

Note: The lifetime of the surface barrier detector is finite. Do not allow beam to pass through a target unnecessarily. Insert BS-2 between spectrum acquisitions.

43.4.3 Measuring the Beam Energy

After inserting a foil in the beam, connect the cable from the “TO MCA” connector on the Linac electronics patch panel to the “unipolar output” of the Spectroscopy Amplifier. (If not already connected to the spec. amp., it will be connected to the output of the TAC).

The Linac control computer can perform an energy measurement either in the Control Screen (the screen usually present after set up) or else in the Setup Screen. If you are in the Control Screen, simply hit “M”. A spectrum will be accumulated, its centroid determined, and a value for the centroid energy using the current MCA energy calibration will be displayed.

If the MCA is not initialized, an error message will tell you. In this case you must exit the Control Screen (hit “ESC”) and go to the Linac Setup Menu. After this menu comes up select the “Initialize MCA” option and follow instructions. After initialization the energy can be measured from the Setup Menu, “measure energy centroid”, or else you can return to the Control Screen, and hit “M”.

If the MCA does not seem to be acquiring, check that there is beam on cup-5 and that the Linac is in lock (out-of-lock meter reads 100%) – the MCA is gated to the O/L signal. If a spectrum needs to be acquired with the Linac O/L meter reading 0%, you will need to switch the COINC/ANTI switch on the back of the MCA to ANTI.

To see if the energy of the beam from the Linac has shifted, or if the energy resolution has degraded, compare the spectrum obtained with the print-out of the spectrum recorded after Linac setup. This should be in the Linac logbook.

43.4.4 Measuring the Time Spectrum of the Beam from the Tandem

Because of the location of the ‘energy monitor’ chamber, to measure the time structure of the beam from the tandem (i.e. the input beam into the Linac) it is necessary to turn all the resonators off. Unfortunately, it is not sufficient to do this from the Linac

Control Computer – some resonators will still be slightly excited. Instead, go to the Linac hall and manually turn all the R.F. power amps off.

Next insert the target (see 23.4.2) and then connect the “TO MCA” connector on the Linac Electronics patch panel to the output to the TAC. (If not already connected to the TAC, it will be connected to the output of the Spectroscopy Amp.)

Now to to the Linac Control Computer and select LINAC SETUP MENU from the MAIN MENU. Next select the item MEASURE LE BUNCHER TIMING. A spectrum should then be accumulated on the MCA and displayed on the screen. If the MCA does not accumulate, check that there is beam on cup-5 and that the Linac is in lock (Out-of-lock meter reads 100%) – the MCA is gated to this signal. If a spectrum need to be acquired with the Linac O/L meter reading 0%, you will need to switch the COINC/ANTI switch on the back of the MCA to ANTI.

Compare the spectrum on the screen with the print-out obtained during Linac setup. Check that the channel number of the peak has not shifted by more than 100 ps (~ 2.5 ch) and that the fraction of the beam within ± 0.5 ns of the peak has not degraded significantly.

43.5 Instructions for setting Superconducting Linac Solenoids

1. Determine optimum current settings for the particular beam (A,Q,E) and resonator settings by running TRANSLAC, or looking them up in the Linac log book. Usually it is sufficient to set the solenoids at their “tandem energy only” settings, or leave them as setup for previous run – they run in a persistent current mode.
2. Turn on the 6 solenoid (Hewlett Packard) power supplies in the Linac Hall.
3. Turn on all 6 current programmers in the control room. Unfortunately there are two different types. Cryostat C has a cryomagnetism programmer with built-in current and voltage monitoring. Cryostats B and D have American Magnetics programmers to which current and voltage monitors have been added - one for each cryostat, you select between the solenoids using a push button switch.
4. For one solenoid at a time:
 - (a) Flip current control (ramp control) switch to the “up” position. Watch the current ramp up fairly quickly to the current limit set by the “current limit” pots (pots not calibrated). The “current limit” LED will light.
 - (b) Open the persistence switch by turning on the persistence switch heater: Turn the key switch clockwise. Watch the current and voltage readings. These may glitch but should settle to their previous values within a second. If they do change, this indicates that there is a mismatch between the persistent current in the coil (if any), and the present current limit setting of the power supply. In particular, if the current drops to zero and starts climbing, this indicates that the coil had “quenched” – lost its persistent current by going normal.

- (c) Slowly adjust the current limit, watching the supply current, to bring the solenoid current to the desired value. This requires care - the rate of change of solenoid current is limited by the controller, you have to give the current time to change. Do not let the current exceed 45 A.
- (d) When you have reached the desired current, close the persistence switch by turning off the persistence switch heater: Turn the key counter-clockwise. Count to 30 to let the switch become superconducting. This effectively isolates the current in the solenoid from the current in the power supply.
- (e) Run-down the power supply current using the current control (ramp control) switch. The current should run down quickly. A slow run down (\sim minutes) implies that the persistence switch has not closed, and that the solenoid current is being run down too.
- (f) Check that the supply current has run down to zero and that the current control/ramp control switch is down.

Important note: The time for which the power supply is delivering current, especially high current, should be minimized. Resistance (I^2R) heating occurs in the solenoids leads within the cryostat, leading to excessive helium boil off. On no account must the power supplies be left with the current non-zero.

5. Repeat (a) - (f) for the other solenoids.
6. Turn off current programmers. (Do NOT run down voltage or current limit pots!)
7. Turn off power supplies in Linac Hall.

43.6 Workhorse-Resonator Calibration Procedures

Use Tek 2445A scope and enter conversion coeffs. Screen.

Level Set

- Turn P.D.P. to ON, disconnect M.O. so damping circuits have no effect on amplitude.
- Use CH-1 for CAN MON signal, 50Ω , 100 mV/div., time base at 10 μ s/div. – so wave is smeared out.
- Start voltage -0.2 V, 0.5 V steps, stop at highest field before going normal. Make sure resonator ‘phase’ (loop phase) is properly optimized.
- Use 3 coeffs. for fit.

Level Monitor

- Scope and resonator set up as far level set.

- Start at 0.1 V can monitor, steps of 0.1 V to max field before going normal.
- Use 3 coeffs. for fit.

Phase Set

- Lock resonator up at optimum field, check lock is O.K.
- Trigger scope* with M.O., CH 2, look at CAN MON, CH 1. Expand time base to give 1.04 ns/div. So 10 div. = 360°.
- Use time markers to measure phase 200%=360°.
- Start at 0.25 V, steps of 0.25 V, to just beyond 360°.
- Use 6 coeffs. fit.

* Or else use phase meter.

43.7 Memorandum: February 22, 1991

(Transcript copy of the original.)

TO: Tandem Faculty, Students and Post Docs

FROM: Ed Myers and Kirby Kemper

DATE: February 22, 1991

Linac Operations

1. Phone calls to staff at night.

THERE ARE TWO KINDS OF “LINAC PROBLEMS”:

- (a) Those which if not attended to can result in a serious loss of uptime and possible equipment damage. A power outage, a cryostat vacuum problem and failure of the helium liquefier fall in to this category. and
- (b) Problems which interfere with operation, but have no other consequences, e.g. loss of beam, loss of resonator phase lock, computer problems.

Whereas staff should be immediately notified of “type a” problems so that they can take appropriate action, this does not apply to problems of “type b”. For example, it is unreasonable to disturb a staff member at 5:00 am in the morning for a problem which can be routinely dealt with at 8:00 am.

2. Linac User Training

As a response to the above, and because one of the lab missions of our lab is to provide exposure of graduate students to scientific equipment, all accelerator users should familiarize themselves with certain operational and troubleshooting procedures.

To this end:

- (a) A member of the group whose experiment is being run must be present during all Linac beam tuning.
- (b) A “Linac User Manual” is being produced (Authors D. Spingler, E. Myers). Although inelegant and incomplete (it always will be), it does contain various troubleshooting procedures. Users should read it and use it. Bring necessary changes and suggestions to the attention of the authors. More sections will be added as time permits.
- (c) Dave Spingler and Ed Myers, time permitting, are willing to answer questions and demonstrate procedures.

- (d) A list of procedures and background information which graduate students should know will be produced. Graduate students will not be allowed to run a linac experiment (i.e. their own experiment) unless they satisfy Dave Spingler or Ed Myers that they are familiar with this information.

43.8 Memorandum: July 27, 1987

(Transcript copy of the original.)

TO: All Tandem Personnel

FROM: Ed Myers

DATE: July 27, 1987

SUBJ: Linac Radiation Safety

Now the Linac is approaching routine operation the problem of radiation safety in the Linac area needs to be revisited. The purpose of this memo is to inform tandem personnel. Of the various potential sources of radiation in the Linac area and to state the procedures that should be followed. An informed attitude to radiation is in everyone's interest - please take time to read these notes. Questions and comments are welcome.

Radiation Dose

The statutory limit for "radiation workers" – anyone with a film badge, over 18 and not pregnant, is a dose of 1.25 REM per quarter. This is the dose you would receive, if while you were at work, you were continuously exposed to a radiation level of 2.5 milliREM per hour throughout the 500 working hours of the quarter:

$$2.5 \text{ mREM/h} * 500 \text{ h} = 1.25 \text{ REM}$$

However, there is no reason for anyone in the Tandem-Linac lab to receive even a small fraction of this dose. In fact, except under exceptional circumstances no one should need to receive a dose above the detection threshold of the film badge, namely 20 mRem (the rough equivalent of a chest x-ray) in any month. This dose corresponds to spending 25 minutes, everyday, in a radiation field of 2.5 mREM/h.

Procedure: It is essential to wear your film badge in any area where you may be exposed to radiation (above background levels).

Sources of Ionizing Radiation in the Linac Area

There are three distinct sources of radiation in the Linac area: the resonators, the accelerated ion beam, and any material (slits, etc.) which has been activated by bombardment with the ion beam.

Resonators

The superconducting resonators, which make up the Linac, produce x-rays when operating. The production of x-rays increases sharply with the R.F. field level at which

the resonators are operating. For example, with a portable Geiger counter placed against the cryostat wall, I have found the radiation from resonators running at 2 MV/m or less to be barely detectable (<0.04 mREM/h), while a resonator running at 2.25 MV/m gave 7 mREM/h measured against the cryostat wall. In our first Linac run, only one resonator was running at 2.25 MV/m. Our aim is to continually increase the operating field levels of our resonators, with some probably reaching 3 MV/m. At this field level, radiation levels of 100 mREM/h or more can be expected near the cryostat walls.

In the “shadow” of the blue radiation fields, x-ray radiation is currently barely detectable. However, this is not the case during resonator conditioning, nor will it be the case as operating field levels of 3 MV/m are approached.

Procedure

A series of Geiger counters have been placed under the cryostats to detect x-rays from the resonators. When the resonators are excited and emitting x-rays, these Geiger counters cause red lights mounted on top of the cryostats to illuminate.

1. Whenever these lights are on, the walkway beside the cryostats, the tunnel under the cryostats and the tops and ends of the cryostats are out of bounds. Anyone needing to work in these areas with the resonators excited should use a Geiger counter to monitor the radiation level first.
2. Whenever working in the shadow of the radiation shield, but near a resonator operating at “high field”, or being conditioned, use a Geiger counter to monitor the radiation level. If in doubt, use a Geiger counter.

Accelerated Ion Beam

The second source of radiation is the accelerated ion beam, or rather, the nuclear reactions produced when the beam strikes various objects. The effective sources are therefore the various slits, apertures, beam stops, magnets boxes along the path of the beam, and finally the experimenters target chamber. Because large fractions of the ion beam are usually rejected at the entrance and exit slits of the 90° magnet, these are usually the strongest sources. The intensity of radiation from a small source (such as a set of slits) fall off with distance according to the “inverse square law” – often the radiation level measured against a set of slits may be quite high, but is negligible a few feet away.

This beam-induced radiation consists mainly of fast neutrons and gamma-rays, and is properly detected with a neutron monitor and Geiger-counter respectively. Although often the radiation will be emitted roughly equally in all directions from the object being bombarded, in some cases the neutron radiation will be much stronger in the directions close to that of the ion beam, that is the neutrons are “forward peaked”. In general, because of their greater penetrating power, and because of their greater biological effectiveness, neutrons pose the greater hazard.

The amount of radiation produced depends on the type of beam, the beam energy, the beam current and on the material being bombarded, and so obviously varies greatly

from experiment to experiment. In general, however, one can expect the radiation to increase as the beam energy increases and as the mass of the ion decreases. For example, the first Linac run used a ~ 20 nA ^{29}Si beam at 95 MeV. Except near slits, the beam induced radiation was undetectable using the Geiger counter and neutron monitor. By contrast, a high current ^6Li or proton beam could produce levels of around 100 mREM/h.

Procedure

A sign on the Linac switching magnet illuminates with the word “Beam” whenever there is an ion beam in the Linac hall (the sign will come on when BS-2 and the source Faraday cup are both open).

1. When a beam is being run in the Linac area, the doors to the hallway will be locked from the inside. All access will be through the control room and target room 1 and is to be controlled by the accelerator operator.
2. Once an experiment is running, a radiation survey will be carried out, and areas where the radiation is above 2.5 mREM/h will be roped off. If in doubt the radiation in any area you need to spend time in, use the neutron monitor and Geiger counter.
3. Although it is desirable to disrupt data taking as little as possible, the ion beam can be prevented from entering the Linac by inserting the “Low Energy Faraday Cup”.
4. Those filling liquid N_2 dewars must check with the control room first. If they open the doors to the hallway they are responsible for preventing any unauthorized entry.

Activated Material

The third source of radiation is the radioactivity induced in material (slits, targets, etc.) that has been bombarded by an ion beam for a period of time. The radiation, mainly γ -rays and β -rays, can be detected with a Geiger counter. The amount of activity depends on the type, energy and currents of the bombarding beams, on the material being bombarded, and the length of time for which it was bombarded, and the length of time elapsed since bombardment.

Procedure

Use a Geiger counter before working on, or handling any device that has been bombarded by an accelerated ion beam. Be especially careful to contain any loose radioactive material. For proper disposal, contact Radiation Safety.

Sources of ionizing Radiation in the Tandem Area and Target Room 1

The situation here is unchanged. This section just serves as a review of existing procedures.

In the Tandem area the sources of radiation are the Tandem itself, the accelerated ion beam, activated material and the ion sources. In the target room there is the ion beam and the possibility of activated material.

Tandem

The terminal and acceleration tubes near the terminal can be a strong source of x-rays, depending on the operating conditions (terminal voltage, beam current, etc.). Radiation levels at the tank wall near the terminal of 100 mREM/h are not uncommon.

Procedures

Never walk past the center of the Tandem when it is operating. To get from one end to the other, go through the Control Room.

Accelerated Ion Beam

The main factors on which the level of radiation resulting from the accelerated ion beam depend have been mentioned above. As regards to the Tandem, little nuclear radiation (as opposed to x-rays) is to be expected at the Low Energy end – except for proton, deuteron and ^3He , ^4He beams. Significant levels of γ -rays and neutrons are to be generally expected at the High Energy end of the Tandem. And at various places along the beam path into the target room and to the experimenters target. Again, in general, higher currents, higher energies and lighter projectiles all tend to produce more radiation. Usually the strongest sources will be the entrance and exit slits of the 90° magnet.

Procedure

1. Do not use the route past the H.E. end of the Tandem to access the Linac hall when there is a beam from the Tandem. If beam is being run in the Linac area, use the route through the target room 1. If beam is being run in the Target room 1, enter and exit the Linac through the door in the hallway.
2. If radiation at the entrance to the H.E. end of the Tandem exceeds 2.5 mREM/h, the radiation door will be closed to prevent access.
3. If radiation at the entrance to the Target Room 1 area exceeds 2.5 mREM/h, the radiation door will be closed to prevent access.

Ion Sources

The high voltages involved with ion sources result in some x-rays during operation.

For example, 2 mREM/h is typically measured near the injection magnet when the sputter source is operating at 120 kV (However, as with all high voltage equipment, a greater hazard by far is the possibility of electrocution).