



Instruments That Advance The Art

Pixie-16

User Manual

Version 3.06
September 13, 2019

Hardware Revisions: B, C, D, F

XIA LLC
31057 Genstar Rd
Hayward, CA 94544 USA
Email: support@xia.com
Tel: (510) 401-5760; Fax: (510) 401-5761
<http://www.xia.com/>

Information furnished by XIA LLC is believed to be accurate and reliable. However, no responsibility is assumed by XIA LLC for its use, or for any infringements of patents or other rights of third parties which may result from its use. No license is granted by implication or otherwise under any patent or patent rights of XIA LLC. XIA LLC reserves the right to change hardware or software specifications at any time without notice.

Table of Contents

Safety	5
Specific Precautions	5
Power Source	5
User Adjustments/Disassembly	5
Detector and Preamplifier Damage	5
Servicing and Cleaning	5
Warranty Statement	6
Contact Information:	6
Manual Conventions	7
1 Introduction	8
1.1 Pixie-16 Features	9
1.2 Specifications	10
1.3 System Requirements	11
1.3.1 Pixie-16 Crate	11
1.3.2 Host Computer	11
1.3.3 Drivers and Software	12
1.3.4 Detector Signals	12
1.3.5 Power Requirements	12
1.3.6 Connectors and Cabling	12
1.4 Software and Firmware Overview	12
1.5 Front Panel	12
1.5.1 16 Analog Signal Input Connectors (all Pixie-16 revisions)	13
1.5.2 LVDS I/O Port (all Pixie-16 revisions)	13
1.5.3 Digital I/O Connectors (A, B, C, D, E in red color font) (Rev. F Modules only)	14
1.5.4 Front Panel LEDs (all Pixie-16 revisions)	16
1.5.5 3.3V I/O Connector (Rev. D Modules only)	17
1.5.6 GATE Inputs (Rev. D Modules only)	17
1.5.7 3.3V I/O Connector (Rev. B and C Modules only)	18
1.5.8 Digital Input/output Signals Supported by Standard Firmware (all Pixie-16 revisions)	19
1.6 Front End Attenuation and Termination	21
1.6.1 Rev. F Modules	21
1.6.2 Rev. B, C, D Modules	22
1.7 Operating Multiple Pixie-16 Modules Synchronously	22
1.7.1 Clock Distribution	22
1.7.1.1 Individual Clock Mode	23
1.7.1.2 PXI Clock Mode	23
1.7.1.3 Daisy-chained Clock Mode	24
1.7.1.4 Multi-Crate Clock Mode	24
1.7.2 Trigger Distribution and Run Synchronization	28
2 Installation	30
2.1 Hardware Setup	30
2.2 Software Installation in Windows	32
2.3 Software Installation in Linux	33
2.4 Getting Started	34
2.4.1 Startup	34
2.4.2 Settings	35

2.4.3	Run.....	35
2.4.4	Results.....	36
3	Navigating the Pixie-16 User Interface.....	37
3.1	Overview.....	37
3.2	Startup.....	37
3.3	Settings.....	38
3.3.1	Filter.....	39
3.3.2	Analog Signal Conditioning & Acquire ADC Traces.....	39
3.3.3	Histogram Control.....	40
3.3.4	Decay Time.....	40
3.3.5	Pulse Shape Analysis.....	40
3.3.6	Baseline Control & Acquire Baselines.....	41
3.3.7	Control Registers.....	41
3.3.8	CFD Trigger.....	45
3.3.8.1	100 MHz and 250 MHz Pixie-16 modules.....	45
3.3.8.2	500 MHz Pixie-16 modules.....	47
3.3.9	Trigger Stretch Lengths.....	48
3.3.10	FIFO Delays.....	49
3.3.11	Multiplicity and Coincidence.....	51
3.3.11.1	Illustrations of Multiplicity, Coincidence and Group Triggers.....	51
3.3.11.2	Parameters for Configuring Multiplicity, Coincidence and Group Triggers.....	55
3.3.11.3	Local Fast Trigger Gated by External Fast Trigger.....	58
3.3.11.4	Channel Validation Triggers.....	58
3.3.11.5	Module Validation Trigger.....	61
3.3.11.6	Module Fast Trigger.....	63
3.3.12	QDC.....	65
3.4	Run.....	65
3.5	Results.....	66
4	Data Acquisition and Data Structures.....	70
4.1	Run Types.....	70
4.1.1	MCA Runs.....	70
4.1.2	List Mode Runs.....	70
4.1.3	Summary of Run Types.....	70
4.2	Output Data Structures.....	71
4.2.1	MCA Histogram Data Structure.....	71
4.2.2	List Mode Data Structures.....	71
4.2.2.1	Event Header.....	71
4.2.2.2	Waveforms.....	72
4.2.2.3	CFD results.....	73
4.2.3	List Mode Data Values.....	74
4.2.3.1	List Mode Time Stamps.....	74
4.2.3.2	List Mode Energy.....	75
4.2.3.3	List Mode Trace Length.....	75
4.2.3.4	List Mode Event Length.....	76
4.2.3.5	List Mode Energy Sums.....	76
4.2.3.6	List Mode Baseline.....	76
4.2.3.7	List Mode QDC Sums.....	76
4.2.3.8	List Mode External Clock Timestamps.....	76
4.2.3.9	Capture Timing of List Mode Data Values.....	77

4.2.4	Settings Files (Run Statistics Included)	77
4.2.4.1	File Format	77
4.2.4.2	File Content	78
5	Hardware Description	79
5.1	Analog Signal Conditioning	79
5.2	Pulse Processing	80
5.3	Digital Signal Processor (DSP) and Event Building	80
5.4	PCI and Trigger Interface	81
6	Theory of Operation	82
6.1	Digital Filters for Radiation Detectors	82
6.2	Trapezoidal Filtering in a Pixie-16 Module	84
6.3	Baselines and Preamplifier Decay Times	85
6.4	Thresholds and Pileup Inspection	86
6.5	Filter Range	88
6.6	Run Statistics	89
6.6.1	Time and trigger counters	89
6.6.2	Count Rates	90
7	Appendix A – Coincidence Example	91

Safety

Please take a moment to review these safety precautions. They are provided both for your protection and to prevent damage to the Pixie-16 module and connected equipment. This safety information applies to all operators and service personnel.

Specific Precautions

Observe all of these precautions to ensure your personal safety and to prevent damage to either the Pixie-16 module or equipment connected to it.

Power Source

The Pixie-16 module is powered through a custom made PXI/Compact PCI 6U crate. Please refer to the crate manual for the correct AC voltage connections. The crate must be powered down to insert and remove the module. **The Pixie-16 module is not hot swappable!**

User Adjustments/Disassembly

To avoid personal injury, and/or damage, always turn off power before accessing the Pixie-16 module's on-board jumpers.

Detector and Preampifier Damage

Because the Pixie-16 module does not provide power for the detector or preamplifier there is little risk of damage to either resulting from the Pixie-16 module itself. Nonetheless, please review all instructions and safety precautions provided with these components before powering a connected system.

Servicing and Cleaning

To avoid personal injury, and/or damage to the Pixie-16 module or connected equipment, do not attempt to repair or clean these units. These modules are warranted against all defects for one (1) year. Please contact the factory or your distributor before returning items for service.

Warranty Statement

XIA LLC warrants that this product will be free from defects in materials and workmanship for a period of one (1) year from the date of shipment. If any such product proves defective during this warranty period, XIA LLC, at its option, will either repair the defective products without charge for parts and labor, or will provide a replacement in exchange for the defective product.

In order to obtain service under this warranty, Customer must notify XIA LLC of the defect before the expiration of the warranty period and make suitable arrangements for the performance of the service.

This warranty shall not apply to any defect, failure or damage caused by improper uses or inadequate care. XIA LLC shall not be obligated to furnish service under this warranty a) to repair damage resulting from attempts by personnel other than XIA LLC representatives to repair or service the product; or b) to repair damage resulting from improper use or connection to incompatible equipment.

THIS WARRANTY IS GIVEN BY XIA LLC WITH RESPECT TO THIS PRODUCT IN LIEU OF ANY OTHER WARRANTIES, EXPRESSED OR IMPLIED. XIA LLC AND ITS VENDORS DISCLAIM ANY IMPLIED WARRANTIES OF MERCHANTABILITY OR FITNESS FOR A PARTICULAR PURPOSE. XIA'S RESPONSIBILITY TO REPAIR OR REPLACE DEFECTIVE PRODUCTS IS THE SOLE AND EXCLUSIVE REMEDY PROVIDED TO THE CUSTOMER FOR BREACH OF THIS WARRANTY. XIA LLC AND ITS VENDORS WILL NOT BE LIABLE FOR ANY INDIRECT, SPECIAL, INCIDENTAL, OR CONSEQUENTIAL DAMAGES IRRESPECTIVE OF WHETHER XIA LLC OR THE VENDOR HAS ADVANCE NOTICE OF THE POSSIBILITY OF SUCH DAMAGES.

Contact Information:

XIA LLC
31057 Genstar Rd.
Hayward, CA 94544 USA

Telephone: (510) 401-5760
Downloads: <http://support.xia.com>
Customer Support: support@xia.com

Manual Conventions

The following conventions are used throughout this manual.

Convention	Description	Example
»	The » symbol leads you through nested menu items and dialog box options.	The sequence Run Results»MCA Histogram directs you to pull down the Run Results menu, and select the MCA Histogram item.
Bold	Bold text denotes items that you must select or click on in the software, such as menu items, and dialog box options.	...click on the Startup tab.
[Bold]	Bold text within [] denotes a command button.	[Start] indicates the command button labeled Start Run.
monospace	Items in this font denote text or characters that you enter from the keyboard, sections of code, file contents, and syntax examples.	Setup.exe refers to a file called “setup.exe” on the host computer.
“ window ”	Text in quotation refers to window titles, and quotations from other sources	“ Acquire ADC Traces ” indicates the window accessed via Settings»Acquire ADC Traces .
<i>Italics</i>	Italic text denotes a new term being introduced, or simply emphasis	<i>rise time</i> refers to the length of the slow filter. ...it is important first to set the energy filter flat top so that it is <i>at least one unit greater than</i> the preamplifier risetime...
<Key> <Shift-Alt-Delete> or <Ctrl+D>	Angle brackets denote a key on the keyboard (not case sensitive). A hyphen or plus between two or more key names denotes that the keys should be pressed simultaneously (not case sensitive).	<W> indicates the W key <Ctrl+W> represents holding the control key while pressing the W key on the keyboard
<i>Bold italic</i>	Warnings and cautionary text.	<i>CAUTION: Improper connections or settings can result in damage to system components.</i>
CAPITALS	CAPITALS denote DSP parameter names	SLOWLEN is the length of the slow energy filter
SMALL CAPS	SMALL CAPS are used for panels/windows/graphs in the GUI.	...go to the READ HISTOGRAMS panel and you see...

1 Introduction

The Digital Gamma Finder (DGF) family of digital pulse processors are capable of measuring both the amplitude and shape of pulses in nuclear spectroscopy applications. The DGF architecture was originally developed for use with arrays of multi-segmented HPGe gamma ray detectors, but has since been applied to an ever broadening range of applications.

The DGF Pixie-16 is a 16-channel all-digital waveform acquisition and spectrometer card based on the CompactPCI/PXI standard for fast data readout to the host. It combines spectroscopy with waveform digitizing and the option of on-line pulse shape analysis. The Pixie-16 accepts signals from virtually any radiation detector. Incoming signals are digitized by 12-bit, 14-bit, and 16-bit, 100 Mega Samples per Second (MSPS), 250 MSPS, and 500 MSPS ADCs. Waveforms of up to 163 μ s in length for each channel can be stored in a FIFO. The waveforms are available for onboard pulse shape analysis, which can be customized by adding user functions to the core processing software. Waveforms, timestamps, and the results of the pulse shape analysis can be read out by the host system for further off-line processing. Pulse heights are calculated to 16-bit precision and can be binned into spectra with up to 32K channels. The Pixie-16 supports coincidence spectroscopy and can recognize complex hit patterns.

Data readout rates through the CompactPCI/PXI backplane to the host computer can be up to 109 Mbyte/s. The standard PXI backplane, as well as additional custom backplane connections are used to distribute clocks and trigger signals between several Pixie-16 modules for group operation. A complete data acquisition and processing systems can be built by combining Pixie-16 modules with commercially available CompactPCI/PXI processor, controller or I/O modules in the same crate.

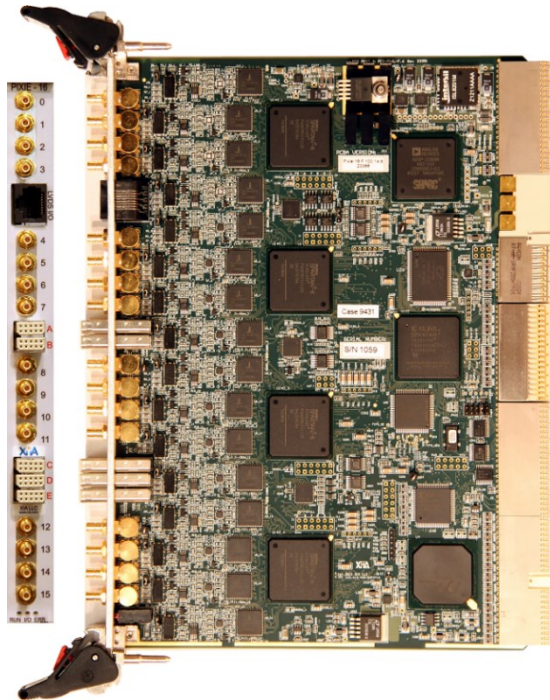

Figure 1-1: Picture of the front and side view of the Pixie-16.

1.1 Pixie-16 Features

- Designed for
 - Segmented germanium detectors,
 - Silicon strip detectors,
 - Arrays of scintillation detectors,
 - Synchronous waveform capture for gamma- ray tracking,
 - Sub-nanosecond timing measurements,
 - Mixed systems with different detector types.
- Accepts input signals directly from detector preamplifier outputs or scintillator/PMT or SiPM combinations
- 12, 14, 16 bits; 100, 250, 500 MSPS ADC
- Two software selectable gain/attenuation settings for each analog input
- Programmable DC-offset for each analog input
- Onboard CFD trigger with adjustable parameters
- Programmable pileup inspection criteria include trigger filter parameters, threshold, and rejection criteria
- Triggered synchronous acquisition across channels and modules of waveforms up to 163 μ s in length
- On-board MCA spectrum from 1K to 32K bins (software selectable), up to 4.3 billion counts per bin
- Event processing and optional pulse shape analysis performed with 100 MHz, 32-bit floating point SHARC[®] DSP
- Event by event list mode data buffered to allow zero dead-time acquisition
- Full speed 32-bit, 33 MHz PCI interface to host computer, up to 109 MBytes/s readout sustained
- Configurable digital inputs and outputs
- More than 120 backplane lines for clock and trigger distribution or general purpose I/O and run synchronization between modules
- Graphical user interfaces to control and diagnose system
- Digital oscilloscope for health-of-system analysis
- Compact C driver libraries available for easy integration in existing user interface

1.2 Specifications

Table 1-1 Detailed Specifications of Pixie-16

Front Panel I/O	
Signal Input	<p>16 analog signal inputs (SMB). Switchable input impedance and attenuation: 50 Ω or 1 kΩ or 4 kΩ (or according to user specification), 1:4 or 1:1 attenuation</p> <p>Jumper selectable 50 Ω input termination</p> <p>Sixteen preamplifier inputs, switchable input impedance and attenuation: 50 Ω or 1 kΩ or 4 kΩ (or according to user specification)</p> <p>Input signal is not recommended to exceed +/-3.5V if 50 Ohm input termination jumper is installed and the 1:4 attenuation is not used</p> <p>Works with common resistive feedback preamplifiers of either signal polarity</p>
Logic Input/output	<p>28 digital inputs/outputs, including:</p> <ul style="list-style-type: none"> 4 high speed LVDS input/output connections 16 LVDS inputs for channel specific veto (or validation) 2 LVDS inputs for module veto (or validation) or general purpose I/O 6 single-ended inputs and 6 single-ended outputs <p>Option for external clock through front panel input. In addition, there are more than 120 digital lines on the backplane for low skew system clock distribution, trigger, run synchronization, and global veto lines, and complex trigger logic, multiplicity information, or data transfers between modules</p>
Backplane I/O	
Clock Input/output	Distributed 50 MHz clock, dedicated PXI_CLK line from slot 2 or daisy-chained
Synchronization	Wired-or SYNC signal distributed through PXI backplane to synchronize timers and run start/stop
Veto	VETO signal distributed through PXI backplane to suppress event triggering
General purpose I/O	More than 120 (121 for Rev F modules, 164 for Rev B/C/D modules) bussed and neighboring lines on custom backplane to distribute multiplicity and triggers and for I/O between modules
Data Interface	
PCI	32-bit, 33MHz Read/Write, external memory or FIFO readout rate to host over 100 MByte/s
Digital Controls	
Input	Choice of two attenuation options through software settable input relay
Gain	Fixed analog voltage gain set to factory standard or per user specification, digital gain adjustment possible
Offset	DC offset adjustment from -1.5V to +1.5V, in 65536 steps

Shaping (Slow Filter)	Digital trapezoidal filter with adjustable rise time and flat top for pulse height computation Rise time and flat top: 0.04 to 80 μ s (0.032 to 65.5 μ s for 250 MHz modules), set independently Adjustable flat top to eliminate ballistic deficit effects
Trigger (Fast Filter)	Digital trapezoidal filter with adjustable rise time, flat top and threshold for pulse trigger detection Rise time and flat top: 0.02 to 1.27 μ s (0.016 to 1.016 μ s for 250 MHz modules), set independently 9-bit threshold values corresponding to 0 to 511 ADC steps
Constant Fraction Discriminator (CFD) trigger	Programmable CFD length, delay and scaling factor
Coincidence or Multiplicity	Programmable coincidence pattern, coincidence window length, fast trigger delays Programmable multiplicity group pattern, multiplicity threshold
Data collection	MCA binning factor and number of bins Waveform length and pre-trigger delay
Data Outputs	
MCA spectrum	32,768 bins, 32 bit deep (4.2 billion counts/bin) for each channel
List mode event data	256K \times 16bit FIFO memory for buffering list mode data which consist of event ID, time stamp (48-bit), CFD time (16-bit), energy (16-bit), and optional waveform, raw energy sums, baseline, and QDC sums Events are time stamped with 100 or 125 MHz clock with fractional CFD time that is captured at full ADC clock rate (100 or 250 or 500 MHz)
Statistics	Real time, live time, input and output counts for each channel
Diagnostics	ADC trace, baseline history, baseline distribution, FFT noise spectrum

1.3 System Requirements

The digital spectroscopy system considered here consists of a host computer, one or more Pixie-16 modules in a Pixie-16 crate, and a gamma ray detector with appropriate power supplies.

1.3.1 Pixie-16 Crate

The Pixie-16 can be operated in any slot from 2 to 14 of a Pixie-16 crate. Slot 1 is used by the crate controller.

1.3.2 Host Computer

The Pixie-16 module communicates with a host computer through a PCI interface. The host computer is usually either an embedded PC installed in slot 1 of the Pixie-16 crate or a remote desktop or laptop that is linked to the crate via a PCI bridge that is also installed in slot 1.

The host computer must have the following minimum capabilities

- ~100 MB of disk space for operation software
- Sufficient disk space for acquired data

- Windows 7/10 (32 bit or 64 bit) (currently still compatible with Windows XP). Operation under Linux is supported, please contact XIA for details.
- There are no minimum processor requirements, but a clock rate of 1 GHz or more and memory of 512 MB or more are recommended.

1.3.3 Drivers and Software

Communication between the Pixie-16 module and the host PC is facilitated by the PCI driver files and API functions provided by PLX Technology (version 7.10). Drivers are provided by the XIA software distribution. Standalone PLX PCI library files can be downloaded from XIA's web site. Please contact XIA for details.

The Pixie-16 software is a Windows based user interface for the Pixie-16 modules. Alternative interfaces are ROOT (under Linux) or command line C programs; demo code is provided on request.

1.3.4 Detector Signals

The Pixie-16 is designed for single exponentially decaying signals. Step pulses or short non-exponential pulses can be accommodated with specific parameter settings. Staircase type signals from reset preamplifiers generally need to be AC coupled.

The amplitude of the detector output signals is not recommended to exceed +/-3.5V if 50 Ohm input termination jumper is installed and the 1:4 attenuation is not used.

1.3.5 Power Requirements

The Pixie-16 consumes roughly between 40W and 50W (depending on ADC variants of 100 MHz to 500 MHz), requiring the following currents from the Pixie-16 crate:

1.8V	3 - 4 A
3.3V	3 - 4 A
5V5	3 - 4 A
-6V	1.5 A

1.3.6 Connectors and Cabling

The Pixie-16 uses SMB connectors for the analog inputs from the detectors. SMB to BNC adapter cables are provided with the module.

A 10pin har-link[®] connector is used for digital inputs and outputs. The pin pitch is 2mm. Matching cables are e.g. Harting 33 27 243 1000 002.

1.4 Software and Firmware Overview

For installation of the software and an introduction to the user interface, please refer to the following chapter of this manual. For details on the driver layer, please refer to the programmer's manual.

1.5 Front Panel

On the front panel of each Pixie-16 module, there are 16 analog signal input connectors, one LVDS I/O port, five digital I/O connectors as well as three LEDs near the bottom of the front panel. In addition, a sticker showing Pixie-16 model number (e.g., P16L-250-14, meaning the 14-bit, 250 MHz variant of the Pixie-16) is affixed to the top handle of the

front panel, and another sticker indicating the serial number of the Pixie-16 module (e.g., S/N 1100) is placed at the bottom handle of the front panel.

1.5.1 16 Analog Signal Input Connectors (all Pixie-16 revisions¹)

Table 1-2 Pixie-16 Analog Signal Input Connectors

Connector Labels	0 to 15 for 16 channels
Connector Type	SMB Jack

Each Pixie-16 module accepts 16 analog input signals, and each input connector is a SMB Jack (male contact) connector.

1.5.2 LVDS I/O Port (all Pixie-16 revisions)

Table 1-3 Pixie-16 LVDS I/O Port

Connected Signals	4 LVDS pairs (FO _{1p} /FO _{1n} , FI _{1p} /FI _{1n} , FI _{5p} /FI _{5n} , FO _{5p} /FO _{5n} , see below for pin layout)
Signal Direction	Input or Output, software configurable
Cable Type	Cat 5 or Cat 6 (the same ones used for Ethernet)

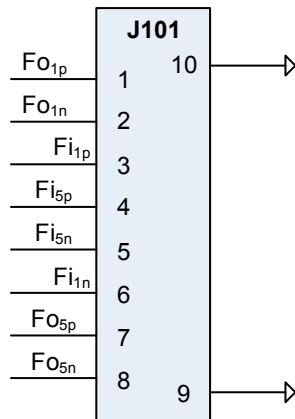

Figure 1-2: Pixie-16 LVDS I/O Port.

Each Pixie-16 module is equipped with one LVDS I/O port on its front panel. LVDS stands for low voltage differential signaling. The LVDS I/O connector is a RJ45 connector, which implies that the same Cat 5 or Cat 6 Ethernet cables can be used to connect signals to or from this I/O port. However, no Ethernet connectivity is available through this Pixie-16 I/O port.

Four differential signal pairs, i.e., between pin-pairs FO_{1p}/FO_{1n}, FI_{1p}/FI_{1n}, FI_{5p}/FI_{5n}, and FO_{5p}/FO_{5n}, are available from this I/O port. Each pair can be configured as either an input or output signal.

The most frequent use of this LVDS I/O port is accepting veto signals in Compton suppressed Clover detector systems. In such systems, each Clover detector has four

¹ Revision for a given Pixie-16 module can be determined based on its serial number: S/N 120-134 -> Rev. B; S/N 135-199 -> Rev. C; S/N 200-274 -> Rev. D; S/N 1000 and up -> Rev. F

individual HPGe crystals which are surrounded by an anti-Compton shield (e.g., BGO crystal + PMT readout). If the veto signals from the anti-Compton shield are generated using external electronics and then converted to LVDS format (e.g., using XIA's LVDS fanout boards), 4 such veto signals can then be input to one Pixie-16 module using the LVDS I/O port. In this way, 4 Compton suppressed Clover detectors (16 HPGe crystal outputs to 16 input channels of the Pixie-16) can be instrumented by one Pixie-16 module.

1.5.3 Digital I/O Connectors (A, B, C, D, E in red color font) (Rev. F Modules only)

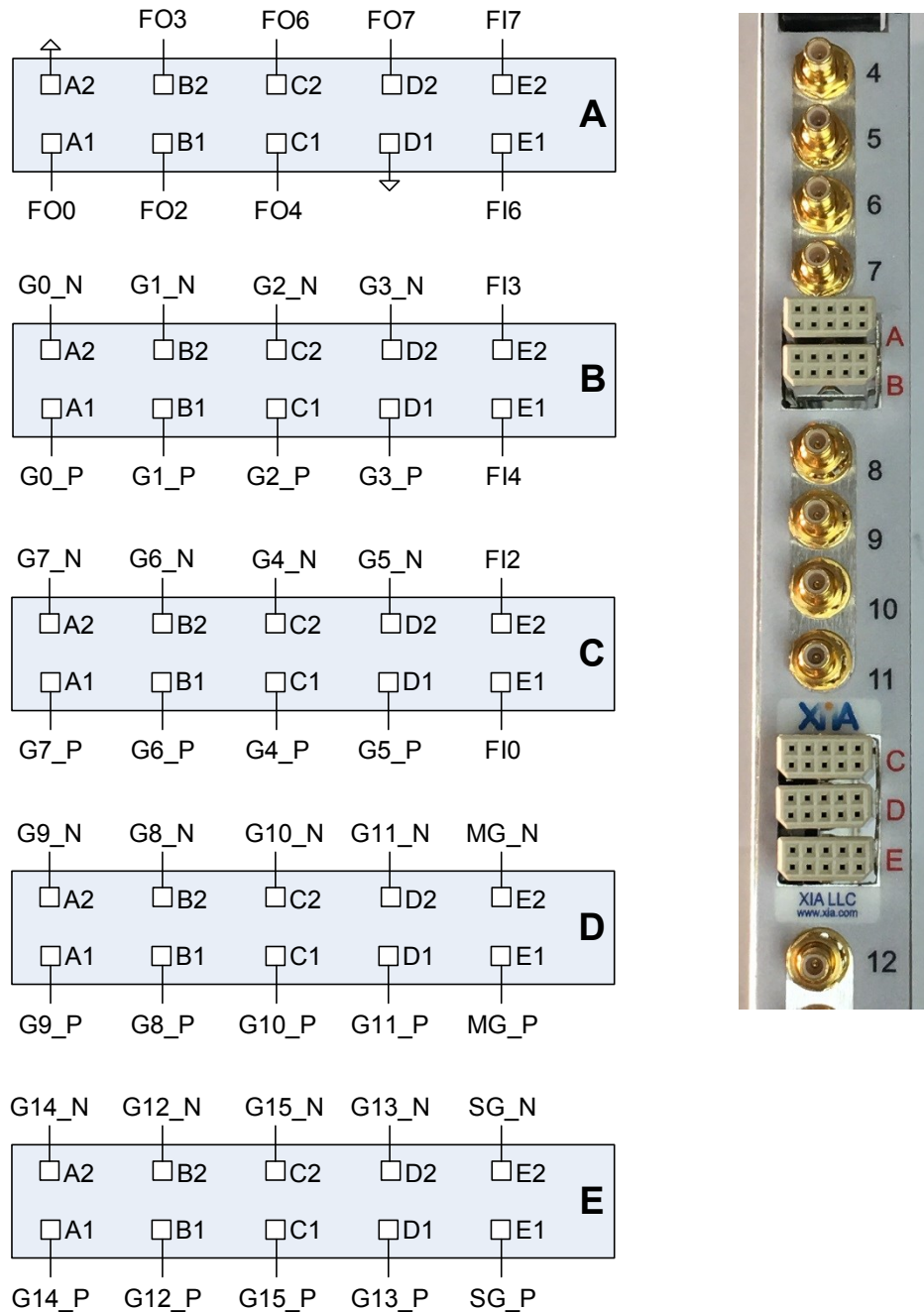

Figure 1-3: Pixie-16 Digital I/O Connectors A, B, C, D and E.

Table 1-4 Pixie-16 Rev. F Module’s Digital I/O Connectors

Connector Type	har-link® (HARTING, 2mm pin spacing)
FI ₀ , FI ₂ , FI ₃ , FI ₄ , FI ₆ , FI ₇	TTL digital input signals (max. 5V)
FO ₀ , FO ₂ , FO ₃ , FO ₄ , FO ₆ , FO ₇	Digital outputs for test/debug purpose (TTL 5V)
G _x _P/G _x _N (x=0-15)	Channel Gate Inputs (0-15 for 16 channels) (LVDS format)
MG_P/MG_N	Module Gate Input (LVDS format)
SG_P/SG_N	Spare Gate Input (LVDS format)

The Pixie-16 Rev. F modules are equipped with five har-link® connectors on its front panel which act as digital I/O connectors. The 2mm pitch har-link® connector from HARTING is designed for high speed data transfer with rates up to 2 Gbit/s. Its EMI shielding, shown in Figure 1-4, guarantees excellent performance in EM-polluted environment. Matching cable assemblies with corresponding part number for each length are listed in Figure 1-4.



Figure 1-4: 2mm pitch har-link® connector from HARTING.²

Each har-link® connector has 2 rows with 5 pins on each row, and is labelled using one of the five letters in red color font, from A to E. The signals connected to each pin of these five connectors are shown in Table 1-4. Among them, FI₀, FI₂, FI₃, FI₄, FI₆, FI₇ are six TTL digital input signals. They can be signals like global fast trigger, global validation trigger, external clock, run inhibit, etc. The specific usage of each input pin is determined by the specific firmware that is downloaded to the Pixie-16 module (see Table 1-9 for input signals supported by the standard firmware). The six digital output signals, FO₀, FO₂, FO₃, FO₄, FO₆, FO₇, which are connected to six test output pins on the System FPGA of the Pixie-16, can be used to assist a user in the process of system setup. These test pins are connected to various internal signals of the Pixie-16 to provide insight of the current status of the system.

The Channel Gate Inputs (0-15 for 16 channels) are LVDS format input signals which independently gate the data acquisition of each of the 16 channels of a Pixie-16 module. The Channel Gate signal is level sensitive signal, i.e., when the level of the Channel Gate Signal is logic high (1), the gate signal is effective; when the level of the Channel Gate Signal is logic low (0), the gate signal is not in use. In normal cases, the Channel Gate Signal is set up to veto the data acquisition in a given channel, i.e., at the time of the arrival of fast trigger in that channel, if the Channel Gate Signal is logic high (1), that fast trigger is discarded since it is vetoed. However, this type of logic can be reversed through setting corresponding registers in the FPGA via software. In such cases, the Channel Gate Signal is set up to validate the data acquisition in a given channel, i.e., at the time of fast trigger

² http://www.harting-usa.com/fileadmin/harting/documents/public/Chapter_07_-_har-link_Interface_Connectors.pdf

in that channel, only if the Channel Gate Signal is logic high (1) will that fast trigger be accepted to have the event recorded.

The Module Gate Input is a LVDS format signal that gates the data acquisition in all 16 channels of a Pixie-16 module. It is also a level sensitive signal, i.e., when the level of the Module Gate Signal is logic high (1), the gate signal is effective; when the level of the Module Gate Signal is logic low (0), the gate signal is not in use. In normal cases, the Module Gate Signal is set up to veto the data acquisition in all 16 channels, i.e., at the time of the arrival of fast trigger in any of the 16 channels, if the Module Gate Signal is logic high (1), that fast trigger of that channel is discarded since it is vetoed. However, this type of logic can be reversed through setting corresponding registers in the FPGA via software. In such cases, the Module Gate Signal is set up to validate the data acquisition in all 16 channels, i.e., at the time of fast trigger in any of the 16 channel, only if the Module Gate Signal is logic high (1) will that fast trigger of that channel be accepted to have the event recorded.

The Spare Gate Input is a LVDS format signal that is reserved for special applications. Such applications typically require development of custom firmware to support special functionalities of the Pixie-16 system.

1.5.4 Front Panel LEDs (all Pixie-16 revisions)

Table 1-5 Front Panel LEDs for the Pixie-16 Modules

LED Name	Color	Function
RUN	Green	ON when run is in progress, and OFF if run is stopped or not started yet
I/O	Yellow	Flashing when there is I/O activity on the PCI bus between the Pixie-16 module and host computer
ERR	Red	ON when there is no more space in the External FIFO for storage of list mode event data, and OFF when there is sufficient space to store at least one more list mode event data (ON does not indicate any actual error condition. Rather, it simply indicates the External FIFO's FULL condition)

Near the bottom of the Pixie-16 front panel, there are three LEDs. They are labelled as RUN, I/O, and ERR, respectively, from left to right. They correspond to three different colors, green, yellow, and red, respectively.

The RUN LED will be turned on when a run in the Pixie-16 module is in progress, and will be turned off when the run is stopped or not started yet. The I/O LED will blink when there is I/O activity on the PCI bus between the Pixie-16 module and host computer. The ERR LED is, in fact, not to signal any error condition in the Pixie-16 module. Instead, it is used to indicate whether or not the External FIFO of the Pixie-16 module is full. It will be ON when there is no more space in the External FIFO for storage of list mode event data, and OFF when there is sufficient space to store at least one more list mode event data. When the External FIFO is full, no more list mode event data can be written into it until the host software reads out part of the data in the External FIFO through the PCI bus.

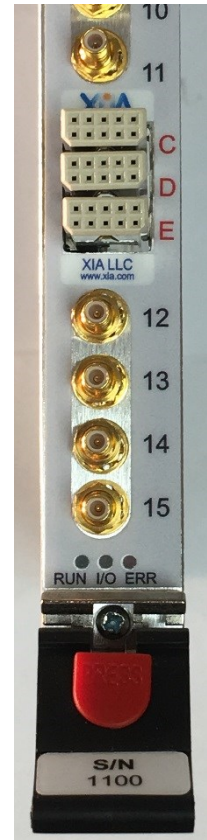

1.5.5 3.3V I/O Connector (Rev. D Modules only)

Table 1-6 Pixie-16 Rev. D Module's 3.3V I/O Connector

Connector Type	Single-ended, 2mm pin spacing
FO ₀ , FO ₂ , FO ₃ , FO ₄ , FO ₆ , FO ₇	Digital outputs for test/debug purpose (3.3V)

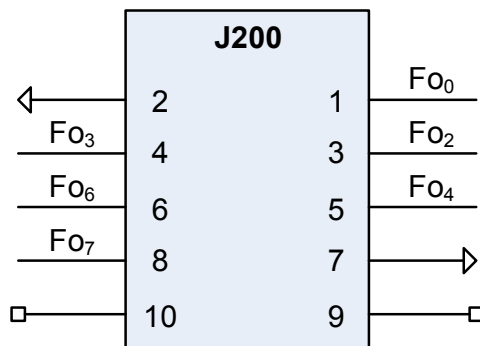

Figure 1-5: Pixie-16 Rev. D Module's 3.3V I/O Connector.

On Rev. D Pixie-16 modules, between analog input SMB connectors for channel 7 and channel 8, respectively, is the 3.3V I/O Connector (J200). It has 10 single-ended pins with 2mm spacing. Pins #1, 3, 4, 5, 6, and 8 are connected to six digital output signals from the System FPGA of the Pixie-16 module, i.e. FO₀, FO₂, FO₃, FO₄, FO₆, FO₇, mainly for the purpose of testing and debugging. Pins #2 and 7 are ground pins, and pins #9 and 10 are not in use.

1.5.6 GATE Inputs (Rev. D Modules only)

Table 1-7 Pixie-16 Rev. D Module's GATE Inputs

Connector Type	Amphenol FCI® 55 Position Header, 2mm pin spacing
FI ₀ , FI ₂ , FI ₃ , FI ₄ , FI ₆ , FI ₇	TTL digital input signals (max. 5V)
Gx _{in} ⁺ /Gx _{in} ⁻ (x=0-15)	Channel Gate Inputs (0-15 for 16 channels) (LVDS format)
MG _{in} ⁺ /MG _{in} ⁻	Module Gate Input (LVDS format)
SG _{in} ⁺ /SG _{in} ⁻	Spare Gate Input (LVDS format)

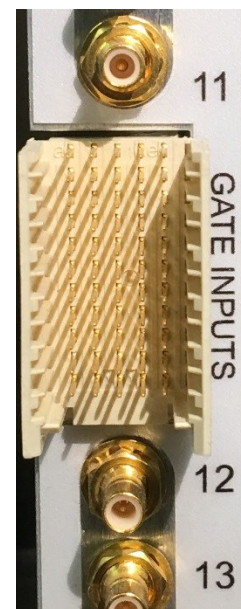

On Rev. D Pixie-16 modules, between analog input SMB connectors for channel 11 and channel 12, respectively, is the GATE INPUTS connector. This connector is an Amphenol FCI® 55 Position Header with 2mm pin spacing. The layout of these 55 pins is shown in Figure 1-6. The 11 pins from the middle pin column (J150C) are all tied to the Ground. Among the first 8 rows of the GATE INPUTS connector, each differential pair of pins from the A/B columns (J150A/J150B) or the D/E columns (J150D/J150E) corresponds to one channel's GATE INPUT, which has the LVDS format, e.g. Gx_{in}⁺/Gx_{in}⁻ (x=0-15). Differential pair of pins at J150A3/J150B3 is the Module Gate Input signal, MG_{in}⁺/MG_{in}⁻. Channel Gate Input signal can be used to veto or validate that given channel's own trigger. Module Gate Input signal works on the whole module level, i.e. it can be used to veto or validate all 16 channels' own trigger of that given module. Differential pair of pins at J150D3/J150E3 is the Spare Gate Input signal, SG_{in}⁺/SG_{in}⁻. Spare Gate Input signal can be used for special applications which require a custom firmware.

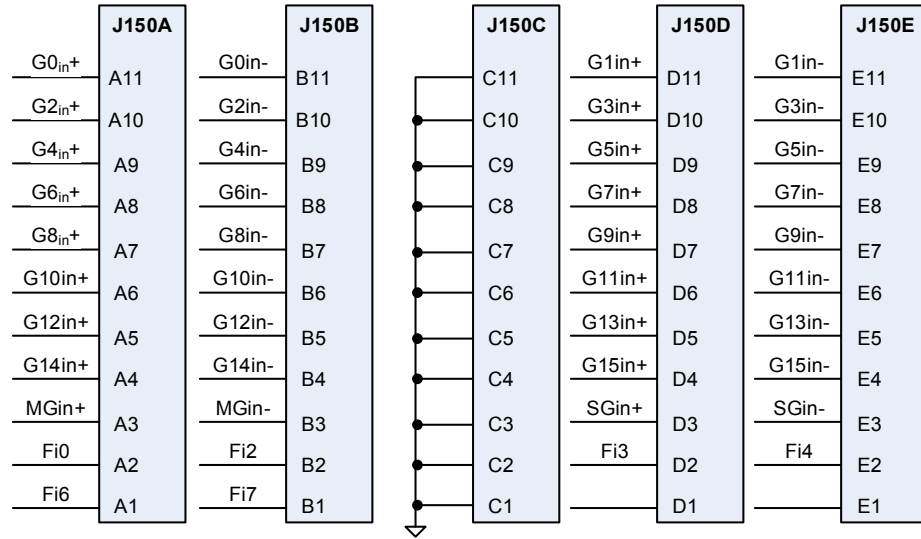

Figure 1-6: Pixie-16 Rev. D Module’s GATE INPUTS Connector.

On Rev. D Pixie-16 modules, the TTL digital input signals (max. 5V), i.e. Fi0, Fi2, Fi3, Fi4, Fi6, Fi7, are distributed among the bottom two rows of the GATE INPUTS Connector, as illustrated in Figure 1-6.

1.5.7 3.3V I/O Connector (Rev. B and C Modules only)

Table 1-8 Pixie-16 Rev. B and C Module’s 3.3V I/O Connector

Connector Type	Single-ended, 2mm pin spacing
Fi0, Fi2, Fi3, Fi4, Fi6, Fi7	TTL digital input signals (max. 5V)
FO0, FO2, FO3, FO4, FO6, FO7	Digital outputs for test/debug purpose (3.3V)

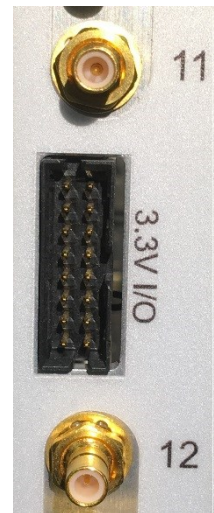
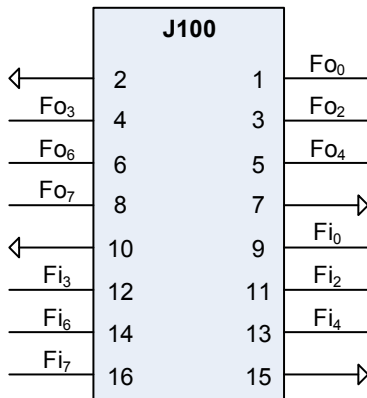

Figure 1-7: Pixie-16 Rev. B and C Module’s 3.3V I/O Connector.

On Rev. B and C Pixie-16 modules, between analog input SMB connectors for channel 11 and channel 12, respectively, is the 3.3V I/O Connector (J100). It has 16 single-ended pins with 2mm spacing. Pins #1, 3, 4, 5, 6, and 8 are connected to six digital output signals from the System FPGA of the Pixie-16 module, i.e. FO₀, FO₂, FO₃, FO₄, FO₆, FO₇, mainly for the purpose of testing and debugging. Pins #2, 7, 10 and 15 are ground pins. Pins #9, 11, 12, 13, 14 and 16 are connected to the six TTL digital input signals (max. 5V), i.e. Fi₀, Fi₂, Fi₃, Fi₄, Fi₆, Fi₇.

1.5.8 Digital Input/output Signals Supported by Standard Firmware (all Pixie-16 revisions)

The standard firmware of the Pixie-16 supports input and output of digital signals through its front panel I/O connectors, which were discussed earlier.

Table 1-9 shows the five TTL digital input signals supported by the Pixie-16 standard firmware. Among them, the signals EXT_TS_CLK and EXT_TS_CLR are used for external timestamping in the Pixie-16, i.e. the Pixie-16 accepting an external clock signal (the frequency of this external clock is not recommended to exceed about 20 MHz in order to avoid the clock signal integrity issue), counting such clock signal with a 48-bit counter, and outputting such counter value to the list mode data stream when an event trigger occurs. The external timestamping is useful for synchronizing the Pixie-16 data acquisition system with another data acquisition system through correlating the external timestamps of the events recorded by both systems.

The INHIBIT signal is used by an external system to inhibit the data acquisition run in a Pixie-16 system when synchronization requirement is enabled in the Pixie-16 modules. It is a level sensitive signal, i.e. when the INHIBIT signal is at the logic high level, the run in the Pixie-16 won't start. Only when the INHIBIT signal goes to the logic low level will the run start in the Pixie-16. During the run, if the INHIBIT signal returns to the logic high level, the run will be aborted.

The EXT_FASTTRIG signal is the external fast trigger signal, which can be used to replace the local fast trigger for recording events in the Pixie-16 modules. The EXT_VALIDTRIG signal is the external validation signal, which can be used to validate events in the Pixie-16 modules.

Table 1-9 Pixie-16 TTL Digital Input Signals

TTL input signals	Connected signals in standard firmware	Direction	Description
FI ₀	EXT_FASTTRIG	Input	External fast trigger signal
FI ₂	INHIBIT	Input	Run inhibit signal
FI ₃	EXT_TS_CLK	Input	External timestamp clock signal
FI ₄	EXT_VALIDTRIG	Input	External validation signal
FI ₆	not used		
FI ₇	EXT_TS_CLR	Input	External timestamp clear signal

Table 1-10 shows the Pixie-16 connector J101 LVDS I/O port signals. This J101 LVDS I/O port can use the regular Ethernet cable for connection but it does not have Ethernet connectivity. Among the four LVDS pairs available from this J101 port, one pair is currently not in use, two pairs are used for input and one pair is used for output. The LVDS_VALIDTRIG is the external validation trigger signal in LVDS format, and the LVDS_FASTTRIG is the external fast trigger signal in LVDS format. The SYNC_LVDS_FP is an output signal from the Pixie-16 module to indicate to external data acquisition systems the synchronization status of the Pixie-16 system so that both data acquisition systems can be synchronized.

Table 1-10 Pixie-16 Connector J101 LVDS I/O Port Signals

Connector J101 Pins	Connected signals in standard firmware	Direction	Description
FO _{1p} /FO _{1n}	not used		
Fi _{1p} /Fi _{1n}	LVDS_VALIDTRIG	Input	External validation trigger signal in LVDS format
Fi _{5p} /Fi _{5n}	LVDS_FASTTRIG	Input	External fast trigger signal in LVDS format
FO _{5p} /FO _{5n}	SYNC_LVDS_FP	Output	Pixie-16 synchronization output signal in LVDS format (to synchronize with other DAQ systems)

Table 1-11 Pixie-16 TTL Digital Output Signals

TTL output signals	Connected signals in standard firmware		Pin on each hardware revision	Description	
	TrigConfig0 [14:12] =000	TrigConfig0 [14:12] =001			
FO ₀	FTRIG_DELAY	FTRIG_DELAY	B: J100-1 C: J100-1 D: J200-1 F: A-A1	Delayed ¹⁾ local fast trigger of channel N ²⁾	Delayed ¹⁾ local fast trigger of channel N ²⁾
FO ₂	FTRIG_VAL	VETO_CE	B: J100-3 C: J100-3 D: J200-3 F: A-B1	Validated, delayed ¹⁾ local fast trigger of channel N ²⁾	Stretched veto trigger of channel N ²⁾
FO ₃	ETRIG_CE	LDPMFULL	B: J100-4 C: J100-4 D: J200-4 F: A-A2	Stretched external global validation trigger of channel N ²⁾	Module level dual port memory (DPM) full status flag
FO ₄	CHANTRIG_CE	SDPMFULL	B: J100-5 C: J100-5 D: J200-5 F: A-C1	Stretched channel validation trigger of channel N ²⁾	System level dual port memory (DPM) full status flag
FO ₆	FTIN_OR	FTIN_OR	B: J100-6 C: J100-6 D: J200-6 F: A-C2	OR of 16 local fast triggers	OR of 16 local fast triggers
FO ₇	TEST_SEL	TEST_SEL	B: J100-8 C: J100-8 D: J200-8 F: A-D2	Selected test signal ³⁾	Selected test signal ³⁾
1) Delayed by External Delay Length 2) N = TrigConfig0[19:16] 3) Test signal selected by TrigConfig0[23:20] 4) All outputs: set TrigConfig0[15]=1 to enable					

Table 1-11 lists the six Pixie-16 TTL digital output signals. Two groups of six output signals can be chosen through software settings (see Table 3-9, bits [14:12] and [19:16] of TrigConfig0). The last output signal TEST_SEL can be further selected through software settings. More details about these signals are provided in later sections of this manual.

1.6 Front End Attenuation and Termination

Each Pixie-16 module has 16 independent analog input channels. To ensure analog input signal can be properly digitized by each channel's ADC, the signal must undergo proper signal conditioning including 1) adjusting DC offset of the analog input signal using each channel's independent Offset DAC and 2) selecting proper input attenuation. The goal of the analog signal conditioning is to fit the analog input signal into the ADC input voltage range (2Vpp).

1.6.1 Rev. F Modules

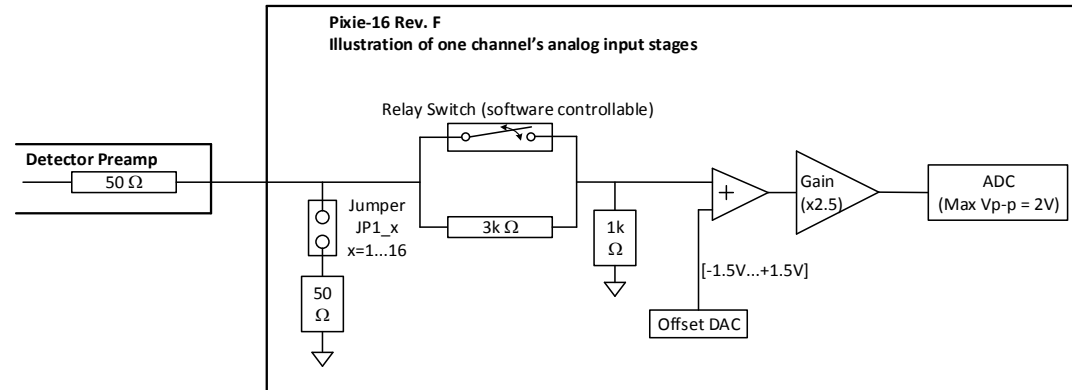

If Jumper is not installed:

If Relay Switch is closed, attenuation is 1:1 (1k Ω termination), and overall effective gain is 2.5;

If Relay Switch is opened, attenuation is 1:4 (4k Ω termination), and overall effective gain is 0.625;

If Jumper is installed and detector preamplifier has 50 Ω output impedance:

If Relay Switch is closed, attenuation is 1:1 (47.6 Ω termination), and overall effective gain is 1.25;

If Relay Switch is opened, attenuation is 1:4 (49.4 Ω termination), and overall effective gain is 0.3125.

Figure 1-8: Rev. F Pixie-16 input stages.

The input stages of the Rev. F Pixie-16 modules are shown in Figure 1-8. Each channel's input termination jumper (JP1_x, x=1...16), shown on the right in red circles, is used to connect the analog input signal to a 50 Ω resistor then to ground. It is installed by default at the factory, and is recommended for being used to avoid input signal reflection when using long coaxial cables to connect detector outputs to the Pixie-16 front panel connectors. However, if the detector outputs have 50 Ω output impedance, the signal will be effectively halved at the input of the Pixie-16 when the input termination jumper is installed.

A relay switch, which is controlled by software for closing or opening, can be used to choose between two attenuation factors and thus two overall effective gains for each of the 16 Pixie-16 input channels. The notes section of Figure 1-9 describes the effective attenuation factor, input impedance, and overall gain for the four cases of the combinations of jumper installation and relay switch. If different overall effective gains than the ones provided by the factory standard (i.e. 2.5/0.625 or 1.25/0.3125) are necessary, please contact XIA for possible custom input

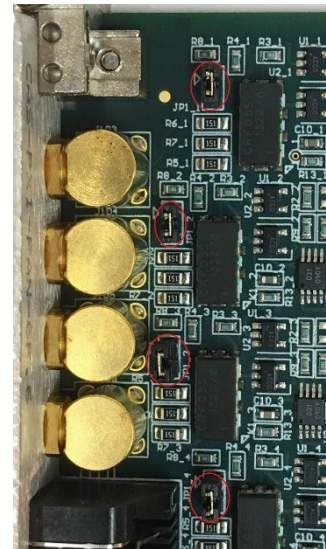

gains. That most likely will involve changing certain parts of the Pixie-16 input stages. Other options will be either to change the gain of the detector preamplifier (if feasible) or to change the high voltage supplied to the detectors (e.g. PMT or SiPM, etc.).

1.6.2 Rev. B, C, D Modules

Different from their Rev. F counterparts, Rev. B, C, D modules do not have the input termination jumpers, and the input signal attenuation factors are also slightly different. Figure 1-9 illustrates the input stages of the Rev. B, C, D Pixie-16 modules. Same as the Rev. F modules, they also have a software controlled relay switch. When the relay switch is closed, the input signal is tied to ground via a 50 Ω resistor, which effectively halves the input signal if it has a 50 Ω output impedance. If the relay switch is opened, the input signal passes through a second branch, which results in a 1:4 attenuation with a 1k Ω input termination. The overall effective gain is 2 or 0.9 when the relay switch is closed or opened, respectively.

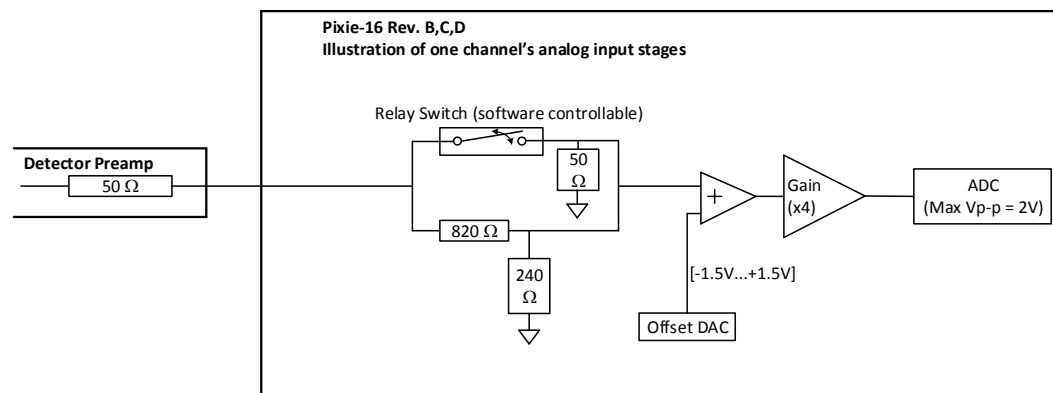

If detector preamplifier has 50 Ω output impedance:
 If Relay Switch is closed, attenuation is 1:1 (50 Ω termination), and overall effective gain is 2;
 If Relay Switch is opened, attenuation is 1:4 (1k Ω termination), and overall effective gain is 0.9.

Figure 1-9: Rev. B, C, D Pixie-16 input stages.

1.7 Operating Multiple Pixie-16 Modules Synchronously

When many Pixie-16 modules are operated together as a system, it may be required to synchronize clocks and timers between them and to distribute triggers across modules. It will also be necessary to ensure that runs are started and stopped synchronously in all modules. All these signals are distributed through the PXI backplane of the Pixie-16 crate.

1.7.1 Clock Distribution

In a multi-module system there will be one clock master and a number of clock slaves or repeaters. The clock function of a module can be selected by setting shunts on Jumper JP101 near the bottom right corner of the board. The 10-pin Jumper JP101 is shown in the picture on the right with those pins labelled in red color. Shunts are provided to connect pins that are

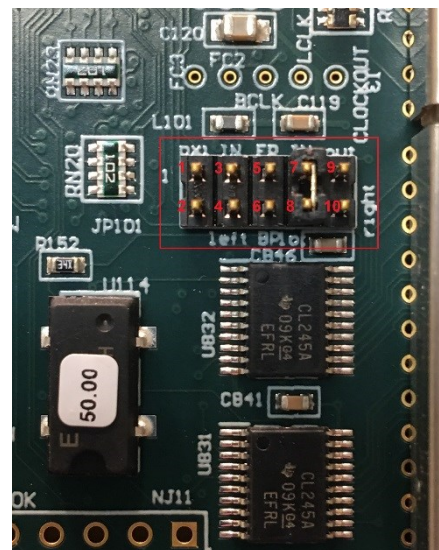

appropriate for each chosen clock distribution mode. Four clock distribution modes, individual clock mode, PXI clock mode, daisy-chained clock mode, and multi-crate clock mode, are described below.

Please note, in 250 MHz or 500 MHz Pixie-16 modules, the frequency of signal processing clock in the FPGA has been divided down to either 125 MHz or 100 MHz, respectively, for more practical implementation of the design. That division might result in different clock phase and thus different timestamp offset for each channel within a given 250 MHz or 500 MHz Pixie-16 module whenever the module is reinitialized. Calibration might be needed to quantify the different timestamp offset for each channel.

1.7.1.1 Individual Clock Mode

If only one Pixie-16 module is used in the system, or if clocks between modules do not need to be synchronized, the module(s) should be set into individual clock mode. Connect pin 7 of JP101 (the clock input) with a shunt to pin 8 (loc – IN). This will use the 50 MHz local crystal oscillator of the Pixie-16 module as the clock source.

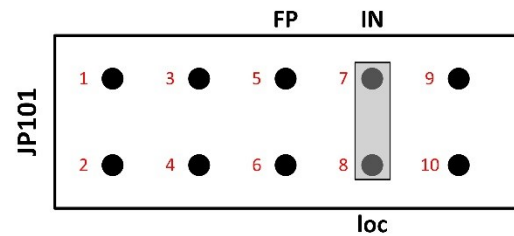
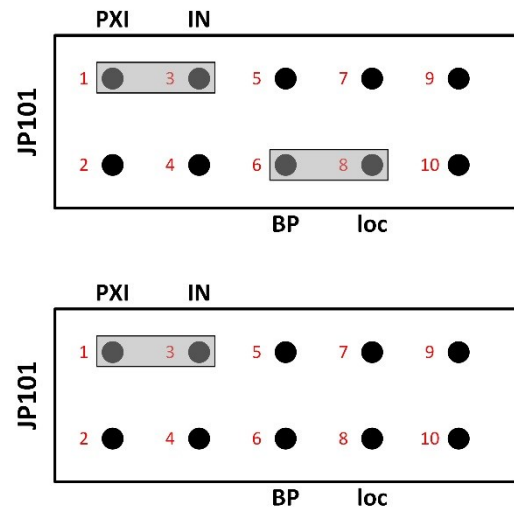

Figure 1-10: Pixie-16 individual clock mode.

1.7.1.2 PXI Clock Mode

The preferred way to distribute clocks among multiple Pixie-16 modules is to use the PXI clock distributed on the backplane. This clock is by default generated on the backplane and is a 10MHz clock signal, which is then repeated by a fan out buffer and connected to each crate slot by a dedicated line with minimum skew (equal trace length to each slot). Although the 10MHz is too slow to be a useful clock for the Pixie-16, it can be overridden by a local clock signal from a Pixie-16 module that is installed in slot 2 through proper shunt settings on the JP101.

A Pixie-16 module can be configured to be the PXI clock master in slot 2 by connecting pins 6 and 8 (loc – BP) of the JP101. All modules, including the clock master, should be set to receive the PXI clock by connecting pin 1 and 3 on JP101 (PXI – IN). In this way, the 50 MHz clock from the Pixie-16 clock master is distributed to all Pixie-16 modules through the backplane with nearly identical clock phase.



Top: PXI clock master (slot 2)
Bottom: PXI clock recipient (slots 3-14)

Figure 1-11: Pixie-16 PXI clock mode.

One other advantage of the PXI clock mode over the daisy-chained clock mode, which will be discussed next, is that except for the Pixie-16 master module, which has to be installed in slot 2, other Pixie-16 slave modules can be installed in any other slot of the Pixie-16 crate. In contrast, when the daisy-chained clock mode is used, all Pixie-16 modules have to be installed next to each other, i.e. no gap is allowed between modules.

1.7.1.3 Daisy-chained Clock Mode

A further option for clock distribution is to daisy-chain the clocks from one module to the other, with each module repeating the clock signal and transmitting it to the neighbor on the right. This requires one master module, located in the leftmost slot of the group of Pixie-16 modules. The master module uses its local crystal oscillator as the input and sends its output to the right (loc – IN, out – right). Other Pixie-16 modules in the crate should be configured as clock repeaters by using the signal from the left neighbor as the input and sending its output to the right (left – IN, out – right). However, as mentioned earlier, there must be no slot gap between modules.

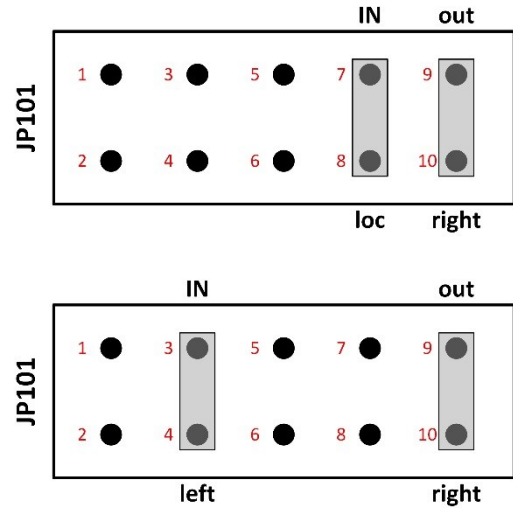

Top: Daisy-chain clock master (leftmost module)
Bottom: Daisy-chain clock repeater

Figure 1-12: Pixie-16 daisy-chained clock mode.

1.7.1.4 Multi-Crate Clock Mode

In multi- crate systems, a global clock signal can be distributed among these crates using dedicated trigger and clock distribution cards, i.e. the Pixie-16 Rear I/O trigger modules, which are available from XIA.

An example of clock distribution between two crates is illustrated below.

Installation of Pixie-16 Modules

Multiple Pixie-16 modules can be installed in two 14-slot Pixie-16 crates, #1 and #2. For clock distribution purpose, crate #1 is called the Master crate, where the system-wide global clock for all Pixie-16 modules is originated, and crate #2 is called the Slave crate, which receives the global clock from the Master crate.

The Pixie-16 module installed in slot 2 of the Master crate is designated as the System Director Module, whose local 50 MHz crystal oscillator acts as the source of the system-wide global clock. The distribution of the clock signal from the System Director Module to all Pixie-16 modules in the 2-crate system is done through the Pixie-16 Rear I/O trigger modules.

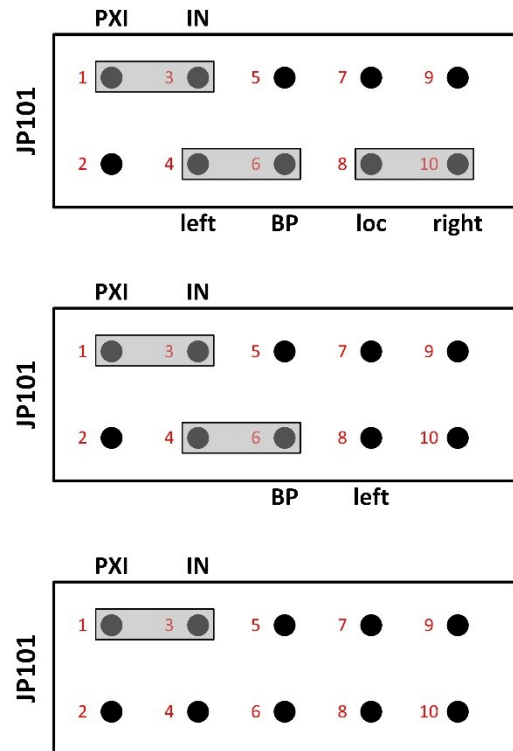

Top: System Director Module
Middle: Crate Master Module
Bottom: Regular Module

Figure 1-13: Pixie-16 multi-crate clock mode.

The Pixie-16 module installed in slot 2 of the Slave crate is called the crate Master module, which is responsible for receiving the global clock from the Master crate and sending such clock to all modules in that crate through length-matched traces on the backplane. The System Director Module is also responsible for sending the global clock to all modules in the Master crate. Therefore, it is also a crate Master module. Other modules in these two crates are regular modules. Table 1-12 shows the different types of modules in a 2-crate system.

Table 1-12 Pixie-16 Module Definitions in a 2-crate System

Crate #	1				
Slot #	2	3	...	13	14
Module	System Director Module / Crate Master Module	Regular Module	...	Regular Module	Regular Module
Crate #	2				
Slot #	2	3	...	13	14
Module	Crate Master Module	Regular Module	...	Regular Module	Regular Module

Clock Jumper (JP101) Settings on the Pixie-16 Modules

For all Pixie-16 modules in a 2-crate system to use the same global clock signal, the clock jumper (JP101) in all modules should be set according to Table 1-13 and Figure 1-13.

Table 1-13 Pixie-16 Clock Jumper JP101 Settings in a 2-crate System

System Director Module	Connect pins 1 and 3, 4 and 6, 8 and 10.
Crate Master Module	Connect pins 1 and 3, 4 and 6.
Regular Module	Connect pins 1 and 3.

Cable Connections for Pixie-16 Rear I/O Trigger Modules

The Pixie-16 Rear I/O trigger modules are installed at the rear side of each crate where a 6U card cage is installed. Figure 1-14 shows a Pixie-16 Rear I/O trigger module is installed directly behind either the Director or the Master module, respectively, to share clock, triggers, and run start or stop synchronization signals among multiple Pixie-16 crates. The rear of the backplane has connectors J3, J4 and J5, but it does not have J1 and J2, since it does not need to use CompactPCI or PXI communication. Typically the first slot at the rear of the backplane with J3, J4, J5 connectors installed is the slot where the Pixie-16 Rear I/O trigger module should be installed. While installing the module, please ensure the alignment of top and bottom rails with the trigger module to avoid damage to the backplane pins.



Figure 1-14: Pixie-16 rear I/O trigger modules.

Figure 1-15 shows the cable connections between two Pixie-16 rear I/O trigger modules that are installed in two separate crates. All connection cables are Category 5 or 6 Ethernet cables and shall have the same length to minimize clock phase difference between Pixie-16 modules in the two crates.

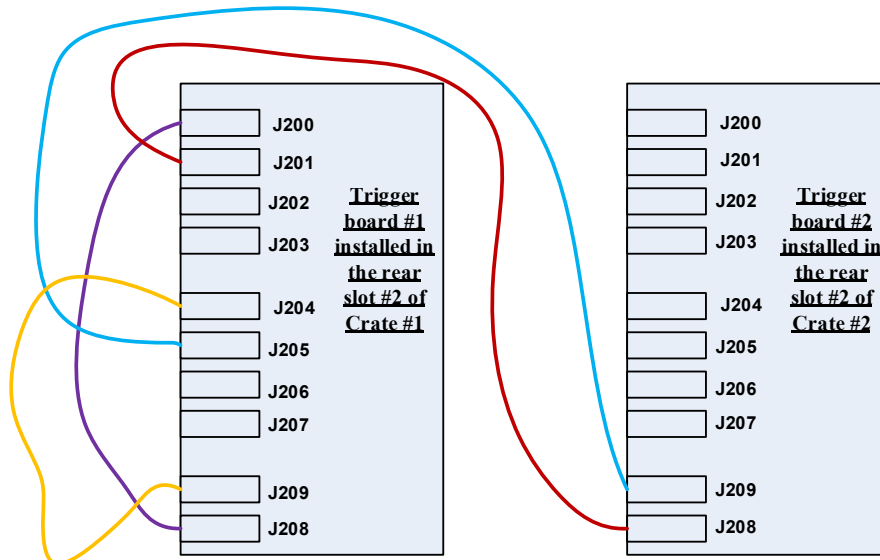

Figure 1-15: Cable connections between two Pixie-16 rear I/O trigger modules.

Jumper Settings on the Pixie-16 Rear I/O Trigger Modules

Trigger module #1 is installed in the rear slot #2 of crate #1. As mentioned earlier, the rear slot #2 is located at the back of the crate and is at the direct opposite side of the front slot #2 of the crate. Care should be taken when installing the trigger module into the rear slot #2 by avoiding bending any pins of the rear side of the backplane, since that could cause the 3.3V pin to be shorted to neighboring ground pin and thus damage the whole backplane. Please note pin numbering for all jumpers on the trigger module is counted from right to left when facing the top side of the module, i.e. the backplane connectors J3 to J5 are on the left (only exception is JP1, which is in vertical orientation and should be counted from bottom to top). A tiny ‘1’ label is painted on the right hand side of the jumpers, indicating pin 1. Figure 1-16 shows the pin ‘1’ in red boxes.

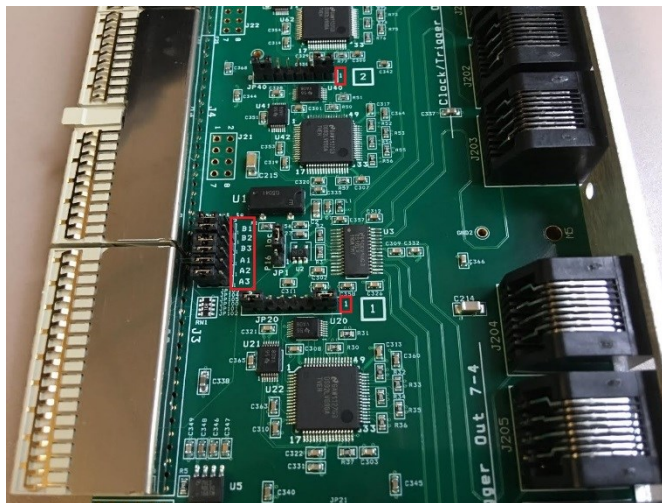

Figure 1-16: Pin numbering for the jumpers on the Pixie-16 rear I/O trigger module.

Table 1-14 shows the jumper settings of the Pixie-16 rear I/O trigger module #1 in a 2-crate system.

Table 1-14 Pixie-16 Rear I/O Trigger Module #1's Jumper Settings

JP1	Connect pins 1 and 2 for "P16"
JP20	Connect pins 2 and 3, 6 and 7
JP40	Connect pins 2 and 3, 6 and 7
JP60	Connect pins 1 and 2, 7 and 8
JP21	Connect pins 2 and 3
JP41	Connect pins 2 and 3
JP61	Connect pins 1 and 2
JP100	Connect pins 2 and 3 (connect to J4)
JP101	Connect pins 2 and 3 (connect to J4)
JP102	Connect pins 2 and 3 (connect to J4)
JP103	Connect pins 2 and 3 (connect to J4)
JP104	Connect pins 2 and 3 (connect to J4)
JP105	Connect pins 2 and 3 (connect to J4)

Trigger module #2 is installed in the rear slot #2 of crate #2. Table 1-15 shows the jumper settings of the Pixie-16 rear I/O trigger module #2 in a 2-crate system.

Table 1-15 Pixie-16 Rear I/O Trigger Module #2's Jumper Settings

JP1	Connect pins 2 and 3 for "loc"
JP20	Connect pins 1 and 2, 7 and 8
JP40	Connect pins 1 and 2, 7 and 8
JP60	Connect pins 2 and 3, 6 and 7
JP21	Don't connect any pin
JP41	Don't connect any pin
JP61	Connect pins 1 and 2
JP100	Connect pins 2 and 3 (connect to J4)
JP101	Connect pins 2 and 3 (connect to J4)
JP102	Connect pins 2 and 3 (connect to J4)
JP103	Connect pins 2 and 3 (connect to J4)
JP104	Connect pins 2 and 3 (connect to J4)
JP105	Connect pins 2 and 3 (connect to J4)

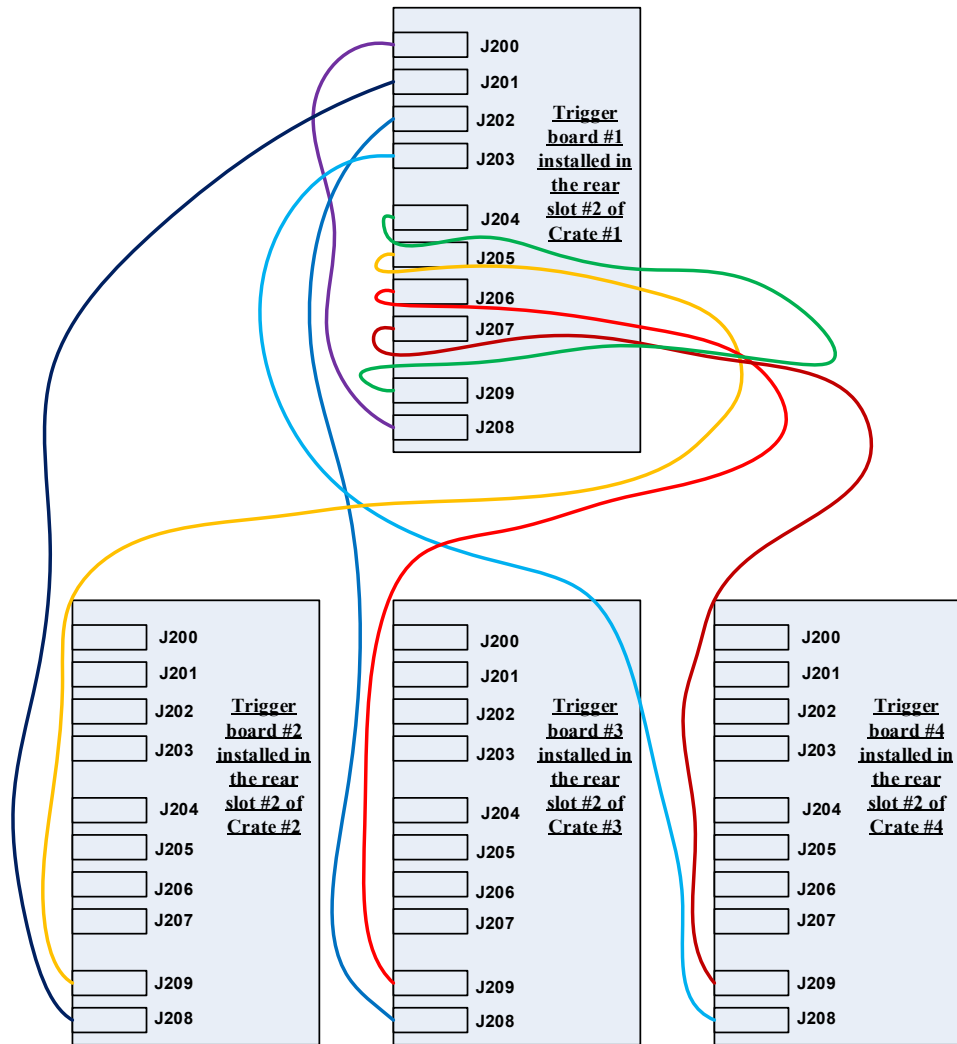

Figure 1-17: Cable connections among four Pixie-16 rear I/O trigger modules.

Please note, if there are a total of four crates, the cable connections among those four Pixie-16 rear I/O trigger modules that are installed in those four separate crates should follow the connection methods shown in Figure 1-17. For the jumper settings on the Pixie-16 rear I/O trigger modules, trigger module #1 and #2 should use the same jumper settings as those in the trigger module #1 and #2 of the 2-crate system (Table 1-14 and Table 1-15), respectively, whereas trigger module #3 and #4 should use the same jumper settings as those in trigger module #2 (Table 1-15).

1.7.2 Trigger Distribution and Run Synchronization

In addition to distributing the global clock signal, the Pixie-16 rear I/O trigger module can also share global triggers and run synchronization signals. The global trigger signals include the global validation trigger and global fast trigger, plus the Pixie-16 FPGA data storage buffers' full flag signal. The run synchronization signals include synchronous run start and stop signals that can be shared among multiple crates.

In order to enable the distribution of such global triggers and run synchronization signals, certain Pixie-16 parameters have to be set properly. The parameter that controls the trigger distribution and run synchronization is the Module Control Register B (ModCSRB). ModCSRB is a 32-bit parameter with each of 32 bits controlling different operation modes of the Pixie-16 module.

For the System Director module that is installed in the Master crate, bits 0, 4, 6 and 11 of ModCSRB should be set to 1 (checked & enabled), as illustrated in Figure 1-18.

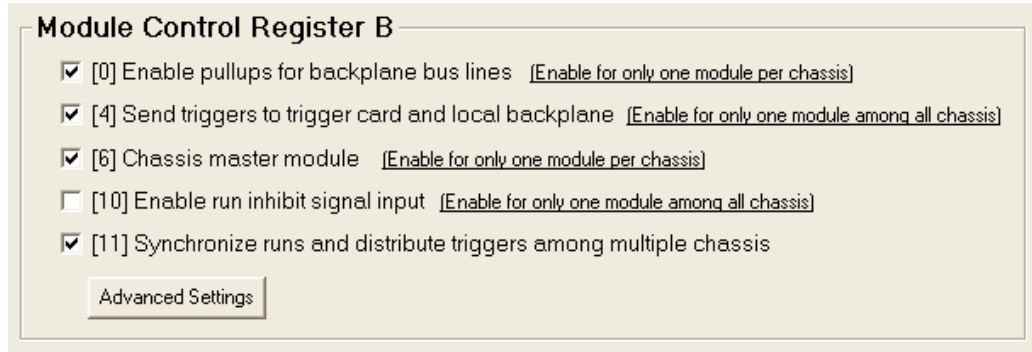

Figure 1-18: ModCSRB bit settings for the System Director Module in the Master crate.

For the Crate Master module that is installed in the Slave crate, bits 0, 6 and 11 of ModCSRB should be set to 1 (checked & enabled), as illustrated in Figure 1-19.

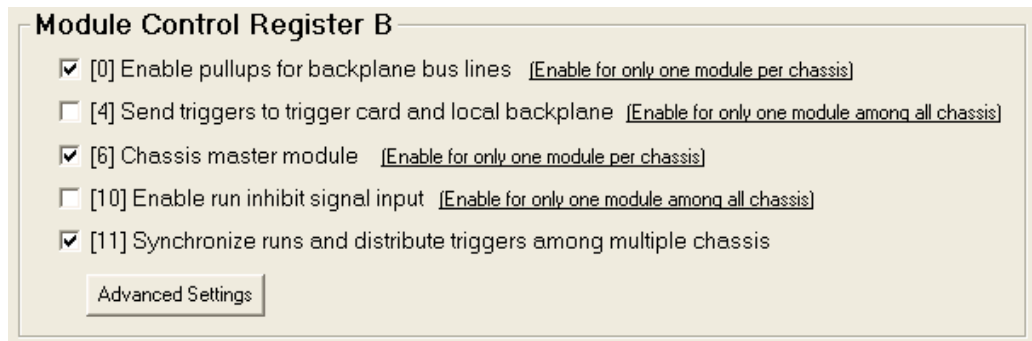

Figure 1-19: ModCSRB bit settings for the Crate Master Module in the Slave crate.

For the General modules that are installed in both the Slave crate and Master crate, bit 11 of ModCSRB should be set to 1 (checked & enabled), as illustrated in Figure 1-20.

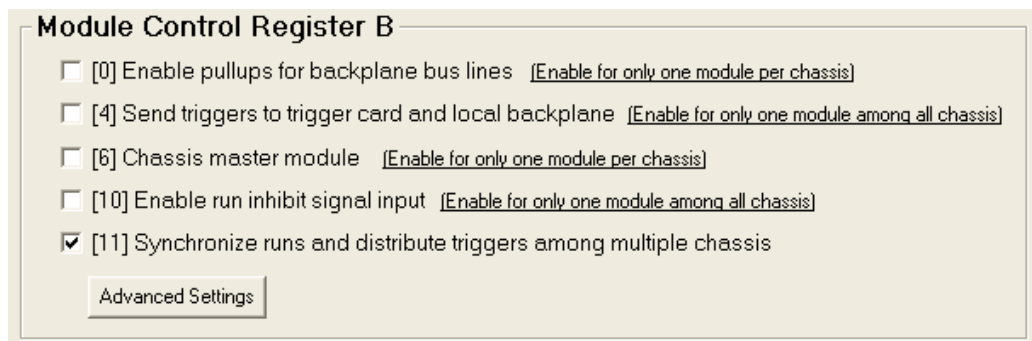

Figure 1-20: ModCSRB bit settings for the General Modules in both Master and Slave crates.

2 Installation

2.1 Hardware Setup

A Pixie-16 system typically consists of a custom 14-slot 6U PXI crate, one or more Pixie-16 modules, a crate controller, and accessories. The system is shipped out of the factory in a large wooden box. We recommend proper storage of this wooden box after unpacking, just in case there is a need to return the crate to factory for service or repair (the nails that were used to seal the box are reusable).

When unpacking the Pixie-16 system, please be sure to collect the following items from the wooden box:

- 1) The 14-slot 6U PXI crate
- 2) Power cord for the crate as well as VME version manual for the crate
- 3) Pixie-16 module(s)
- 4) Crate controller cards to be installed in the crate's slot #1 and computer's PCI slot
- 5) BNC-to-SMB cables
- 6) 2mm shunts for changing jumper settings on the Pixie-16 modules

A picture of a typical Pixie-16 digital data acquisition system is shown in Figure 2-1.

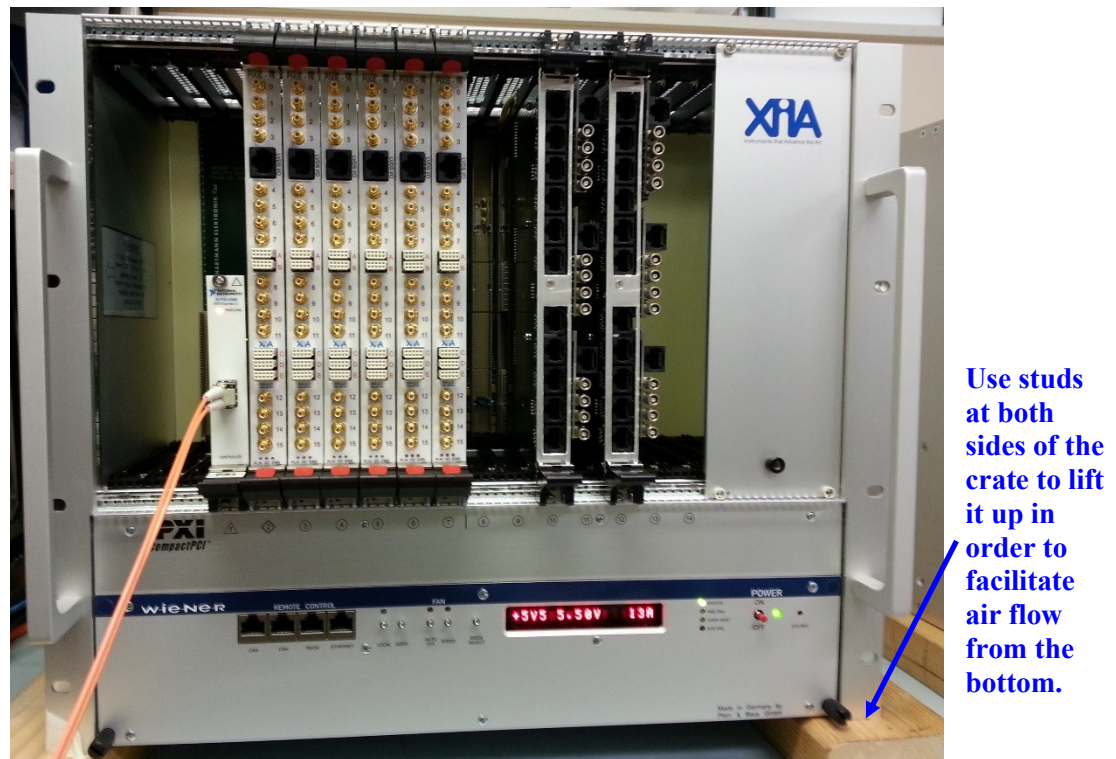

Figure 2-1: A typical Pixie-16 digital data acquisition system.

The Pixie-16 modules must be operated in this custom 6U CompactPCI/PXI crate which provides high currents at specific voltages that are not included in the CompactPCI/PXI

standard. Of the 5 backplane connectors available in a 6U format, the lower two (J1, J2) are defined by the CompactPCI/PXI standard, providing basic supply voltages, PCI host I/O, and basic trigger connections. Pixie-16 modules follow this standard and are thus compatible with any CompactPCI/PXI module that uses these two connectors only. The upper three connectors (J3, J4, J5) are undefined in the CompactPCI/PXI standard. On Pixie-16 modules, these connectors are used for custom power supplies with high currents (1.8V, 5.5V, 3.3V) and for extended trigger distribution. Third party modules or crate using the upper three connectors are most likely not compatible with Pixie-16 modules.

The AC power cords that come with the crates have North America NEMA 5-15 style power plugs on one of the two ends (the other end plugs into the back of the crate) with two flat parallel blades and one ground pin (one example of such power plug is shown in Figure 2-2 top). For non-North America customers, it might be necessary to either find a power socket that is compatible with the NEMA 5-15 style power plugs, or replace the NEMA 5-15 style power plug with the one that is the standard in the customer's country. The replacement can be done by unscrewing the two nails on the NEMA 5-15 style power plug, disconnecting the three wires from the plug (example of exposed wires shown in Figure 2-2 bottom), and then connecting the wires to a new plug chosen by the customer.

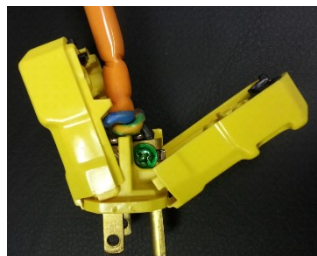

Figure 2-2: An example of the NEMA 5-15 style power plug that come with the Pixie-16 crate and inside look.

The Pixie-16 crate can be controlled either by a remote controller or embedded controller (computer). If using a remote controller, first install the PC hardware of the PCI Bridge in the host PC, and then install the PXI card into slot #1 (the one in red color in most crates) of the crate, and finally connect these PCI bridge cards using the supplied copper or fiber optic cable. If using an embedded controller, install it into slot #1 of the crate and no external connections are required (besides mouse, keyboard and monitor).

Place the Pixie-16 modules into any peripheral PXI slot with the crate still powered down, and then power up the crate, since the Pixie-16 modules are not hot swappable. If using a remote controller, be sure to boot the host computer after powering up the crate. In Linux systems, reloading the drivers for the Pixie-16 manually might be necessary if it is not done automatically.

Connect the detector or preamplifier outputs to the SMB analog inputs of the Pixie-16. SMB-BNC adapter cables are provided by XIA for each module. Make sure to set the input termination appropriately to either 50 Ohm or High-Z by installing or removing, respectively, the jumper on each channel located behind the Pixie-16 front panel before installing the module in the crate.

2.2 Software Installation in Windows

The Pixie-16 Windows software includes the firmware files and DSP code files required to configure a module, Windows drivers and a Visual Basic graphical user interface. All files are included on the distribution CD-ROM (or via download from XIA's web site) and can be installed by running the installation program Setup.exe. Follow the instructions shown on the screen to install the software to the default folder selected by the installation program, or to a custom folder. This folder will contain 7 subfolders named Doc, Drivers, DSP, Firmware, MCA, PulseShape, and Resources. Make sure you keep this folder organization intact, as the interface program and future updates rely on this. Feel free, however, to add folders and subfolders for the output data at your convenience.

After the software installation is completed, turn on the power to the crate, and then reboot the computer. The Pixie-16 modules should appear as "PLX Custom (OEM) PCI 9054 Board" in Windows' Device Manager (Figure 2-3). Otherwise, if Windows asks for drivers for the Pixie-16 modules, please point to the PlxSdk.inf file in the "Drivers" sub-folder under the Pixie-16 software installation folder, e.g. "C:\Program Files\XIA\Pixie16_VB 2.1.0\Drivers". If there is still a PLX driver issue after the aforementioned software installation steps, please go to XIA's web site <http://support.xia.com/default.asp?W372> to download and install the PLX SDK V7.10.

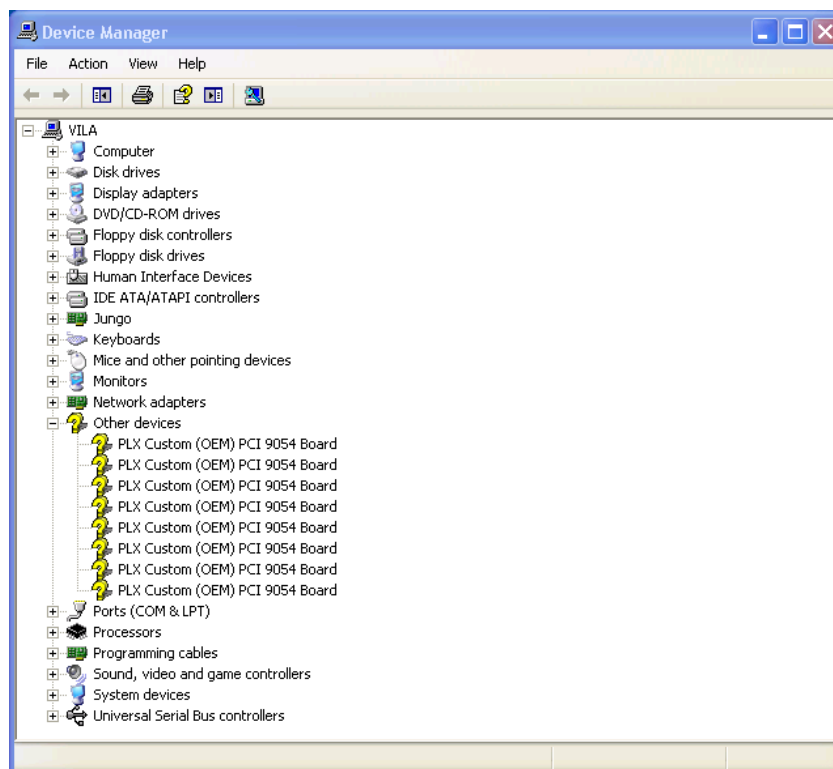

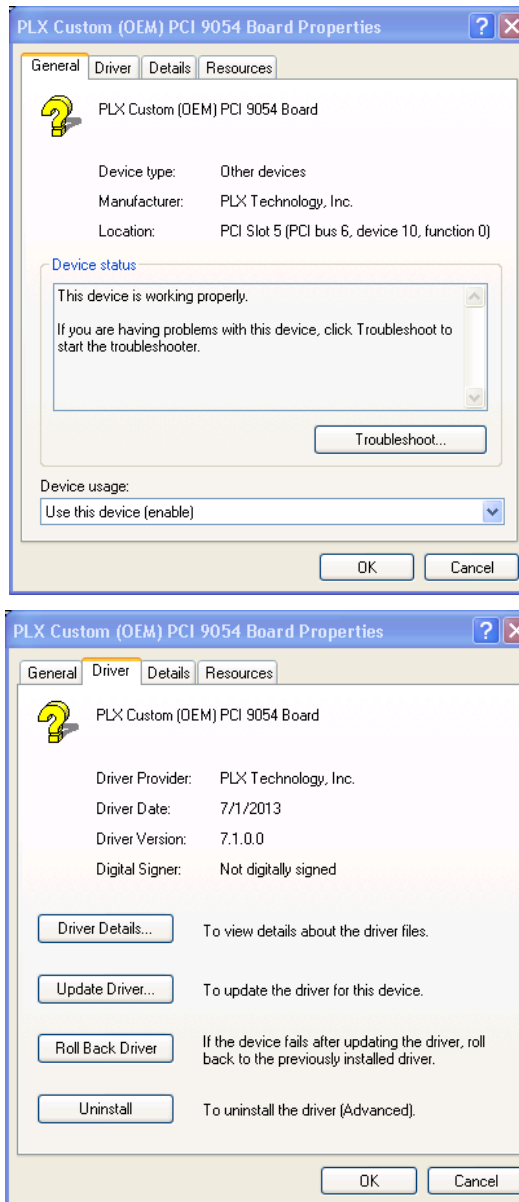

Figure 2-3: Pixie-16 modules shown as “PLX Custom (OEM) PCI 9054 Board” in Windows’ Device Manager.

2.3 Software Installation in Linux

The Pixie-16 is fully supported in Linux operating systems. The Pixie-16 software for Linux is built upon two sets of libraries. The first library is the API library provided by PLX Technology, Inc. (now part of Avago Technologies). The PLX API library, also called PLX Software Development Kit (SDK), provides functions that can be used to perform read or write operations between the Pixie-16 hardware and the Linux computer through the PCI bus (32-bit; 33 MHz) and the PCI 9054 I/O Accelerator from PLX Technology Inc. The PLX PCI 9054 is a 32-bit PCI bus mastering interface chip that is built onto the Pixie-16 hardware. The second library is the XIA Pixie-16 Application Programming Interface (API), which consists of a set of C functions for building various data acquisition applications utilizing the Pixie-16 modules. Complete source codes for both libraries are

provided so that the libraries can be compiled under most commonly used Linux distributions, such as RedHat or Fedora. Source codes for both libraries can be downloaded from the following link: <http://support.xia.com/default.asp?W372>. Please follow the instructions included in the libraries to compile and test them in the Linux environment.

2.4 Getting Started

This section describes the basic steps to get initial list mode traces or MCA histograms with the Pixie-16 system in a Windows software environment. For detailed introduction to the software interface, refer to section 3.

After installation, find the shortcut Pixie16_VB on your desktop and start it with a double click. You can also directly run the file `Pixie_VB.exe` in the installation folder.

The user interface consists of a left control bar with 4 tabs: **Startup**, **Settings**, **Run**, and **Results**, as shown in Figure 2-4. The area to the right will display control panels or graphs. The top menu bar contains links to some frequently used result displays as well as some advanced parameter tables.

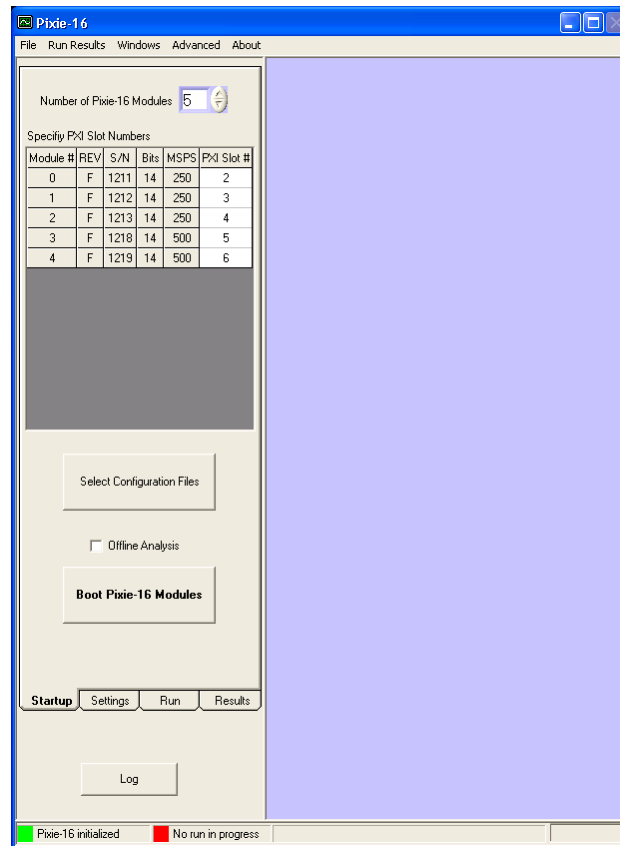

Figure 2-4: The Pixie -16 Windows software user interface.

2.4.1 Startup

To boot the modules, select the default **Startup** tab. First, enter the number of modules and specify the module's slot numbers. You can click on the **[Select Configuration Files]** button to verify the boot files and paths are pointed to the correct installation folder. Then

click on the button **[Boot Pixie-16 Modules]**. The bottom status line should show a green marker indicating that the Pixie-16 modules are initialized successfully. For offline analysis only operation with no Pixie-16 modules installed, check on the *Offline Analysis* box before booting.

2.4.2 Settings

To configure the modules for your detector, go to the **Settings** tab. Click on the **[Acquire ADC Traces]** button to view the input signal for either a single channel or for all 16 channels of the *Module* selected at the bottom of the panel. Click on **[Refresh]** to acquire untriggered traces that are read directly from the ADC. You can adjust the sampling interval to see a longer time period. Pulses from the detector should fall in the range of the ADC with a positive amplitude, i.e. positive going with a rising edge, and no clipping at the upper limit. If the signal is not in range, click on the **[Adjust Offsets]** button to let the software to automatically set the DC offsets, or you could manually adjust the DC offset by clicking on the **[Set DAQ Parameter]** button, then go to the **Analog Signal Conditioning** tab and adjust the offset. While being there, you can also adjust the gain and polarity of each channel.

A very critical parameter for the energy computation is the signal decay time PREAMPTAU. In the SET DAQ PARAMETER panel, go to the **Decay Time** tab to set this value. You can either enter it directly for each channel, or enter an approximate value in the right control, select a channel, and click on **[Find it]** to let the software determine the decay time automatically. In order for the software to successfully find the decay time automatically, the channel should connect to a detector output, and detector count rate should be reasonably high (at least $\sim 1\text{Kcps}$). Otherwise, the automatic Tau finder tool will time out and won't return a PREAMPTAU value successfully. In such case, the PREAMPTAU value will be unchanged. If a PREAMPTAU value is indeed found successfully, click on **[Accept it]** to apply the found value to the channel.

When the signal is in range and the decay time is found, you can store the parameters on file using the **[Save Parameters]** button. Make sure to check the box for *DSP settings* to not only save the GUI settings (such as slot numbers), but also the DSP settings for each module (gain, offset, decay times, etc.). The settings are called DSP settings since all DAQ parameters are first downloaded to the DSP on the Pixie-16, and then the DSP will decode the settings and download them to the FPGAs.

2.4.3 Run

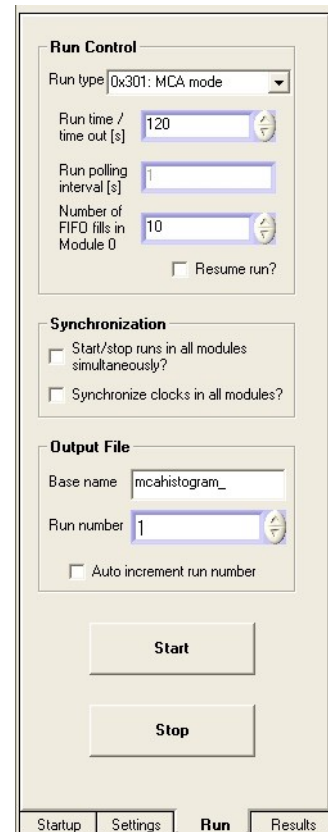
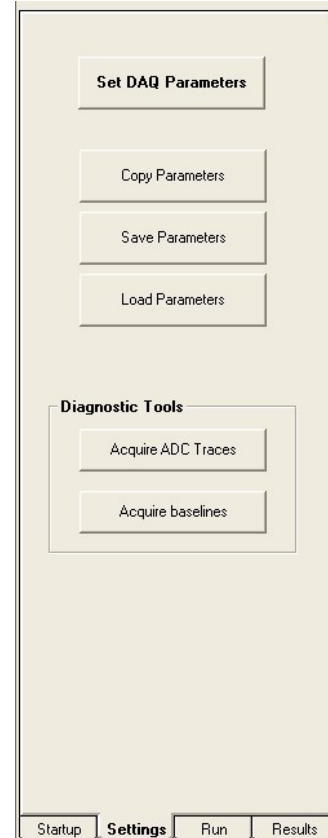

When the DSP settings have been set, at least initially, you can go to the **Run** tab to start a test data acquisition run. Using the *Run Type* control, specify a *list mode run* to acquire waveforms and MCA histograms, or a *MCA mode run* to only acquire histograms. Click on **[Start]** to begin data acquisition.

The run can be stopped either by manually pressing the **[Stop]** button, or by the preset Run time / time out condition (MCA or list mode run), or by the condition of reaching a preset *Number of FIFO fills* in Module 0 (List mode run only). Here each FIFO fill corresponds to approximately 128K list mode data words (32-bit per word).

To synchronize data acquisition runs in all Pixie-16 modules, check the option boxes of both “*Start/stop runs in all modules simultaneously?*” and “*Synchronize clocks in all modules?*”.

The output files are automatically saved into the *MCA* or *PulseShape* folder at the end of the run, depending which run type is chosen. The output file names can be specified in the boxes of “*Base name*” and “*Run number*”. If output files should not be overwritten in subsequent runs, the option “*Auto increment run number*” should be checked.

2.4.4 Results

After the run, statistics, spectra or traces can be viewed by selecting the corresponding item from the **Results** tab. The data is also saved to files that can be imported into other analysis software.

The run statistics results are organized as three columns for each channel, i.e. *Live Time*, *ICR* (*input count rate*) and *OCR* (*output count rate*). By changing the Module Number at the top of the **Results** tab, each module’s run statistics can be viewed. The Processed events box on the **Results** tab is not in use currently. The *Real time* box displays the real time for the previous data acquisition run. The real time starts counting when the run is started and stops when the run is stopped. So it is similar to a wall clock time. The live time, on the other hand, only counts when the Pixie-16 is actually processing events and taking data. For instance, if run synchronization is required among multiple Pixie-16 modules, the real time will start counting when each module is issued a run-start command, but the live time will not start counting until the last module finishes its run initialization routines in the DSP and all modules start data acquisition synchronously. In such case, the live time will be smaller than the real time.

The MCA Spectrum can be viewed and inspected by clicking on the **[Show MCA Spectrum]** button. On the MCA SPECTRUM DISPLAY panel, single channel or 16-channel’s MCA spectra can be viewed and analyzed. The peak position, energy resolution (FWHM), and peak area can be obtained by choosing the ROI (region of interest) on the spectrum.

The List Mode Traces can be viewed and inspected by clicking on the **[Show List Mode Traces]** button. On the LIST MODE TRACES DISPLAY panel, single channel or 16-channel’s list mode traces can be viewed and analyzed. By selecting the event number for the events stored in the list mode data file, each event’s energy, timestamp, and trace can be displayed.

Channel #	Live time [s]
0	9.709
1	9.709
2	9.709
3	9.709
4	9.709
5	9.709
6	9.709
7	9.709
8	9.709
9	9.709
10	9.709
11	9.709
12	9.709
13	9.709
14	9.709
15	9.709

3 Navigating the Pixie-16 User Interface

3.1 Overview

The Pixie-16 graphical user interface (Figure 2-4) provides a user a simple tool to control the Pixie-16 cards. It was written using Microsoft's Visual Basic programming language and its underlying function calls are directed to two dynamic link library (DLL) files, Pixie16AppDLL.dll and Pixie16SysDLL.dll. Those users who are interested in learning more about these DLLs can read the Programmer's Manual. The user interface consists of a work area where DAQ graphs, tables and panels are to be shown, a control bar to the left which contains four tabs with control buttons (**Startup**, **Settings**, **Run**, and **Results**), and status indicators at the bottom. Below we describe the steps of using this interface.

3.2 Startup

After the user interface is launched, the user will see the window with the default **Startup** tab selected in the control bar. Enter the number of modules and specify the module's slot numbers as labeled on the crate. You can click on the **[Select Configuration Files]** button to open the CONFIGURATION FILES & OUTPUT DATA PATHS panel (Figure 3-1) and verify that the boot files and paths are pointed to the correct folder. You can directly input the file name in the boxes, or use the file open icon at the right end of each line to locate a specific file.

Usually, users need only change the DSP parameters file to load alternative settings (same as **[Loading Parameters]** in the **Setting** tab) or change the Output Data Paths to direct the output data into a custom location. However, if you receive firmware updates or custom firmware from XIA, you can click on the **[Select FPGA Firmware Files]** button or the **[Select DSP Code Files]** button to select which FPGA or DSP file to use.

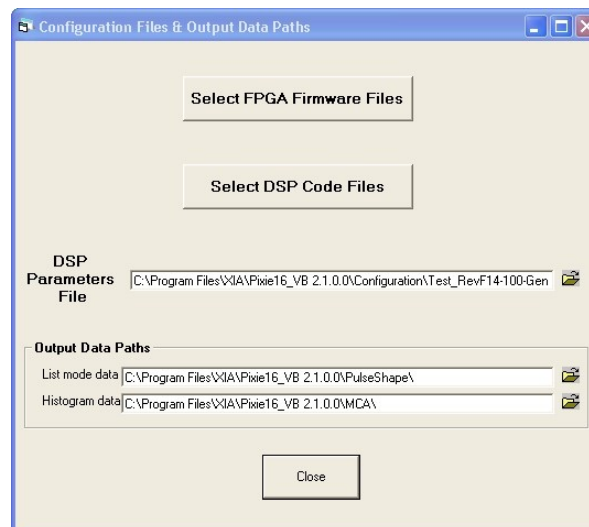

Figure 3-1: The Pixie -16 configuration files & output data paths panel.

When the files and paths are set correctly, click on the button **[Boot Pixie-16 Modules]**. The bottom status line should show a green marker indicating that the Pixie-16 modules have been initialized successfully. If one or more modules failed to boot, click on the **[Log]**

button to view a series of diagnostic messages. The messages are also stored in a file called “*Pixie16msg.txt*” and can be sent to XIA when requesting customer support. This log file is located in the same folder as the user interface program *Pixie16_VB.exe*.

For analysis-only operation with no modules connected, check the *Offline Analysis* box before booting. In offline mode, the user can still access every button or control of the interface. Results from previous acquisitions can also be viewed by loading the results files.

3.3 Settings

The operation of the Pixie-16’s on-board DSP is controlled by a variety of parameters. They can be set using the SET DAQ PARAMETERS panel, opened by clicking on the [Set DAQ Parameters] button in the **Settings** tab. The panel has 12 tabs, as shown in Figure 3-2.

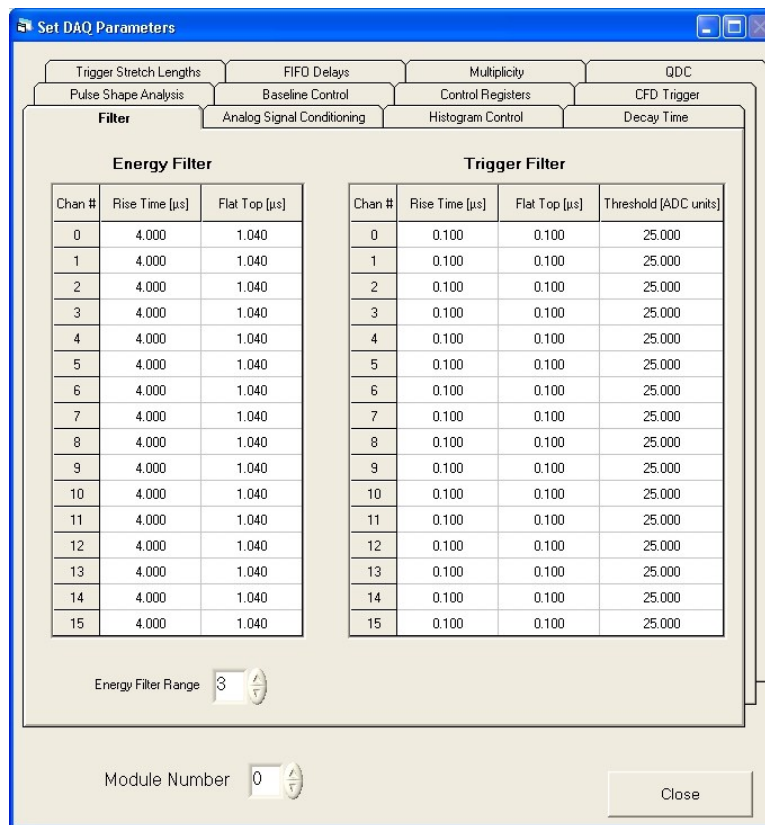

Figure 3-2: The Pixie -16 set DAQ parameters panel.

Using the button in the left control bar, DAQ parameters can be:

Copied from one channel to some or all channels and modules in the system. When copying, first select source module and channel at the top of the copy panel, then select the items to copy on the left (corresponding to the 12 tabs of the SET DAQ PARAMETERS panel), then select the destination channels and modules, and finally click on the [Copy] button.

Saved to disk. When saving, make sure to check the box for *DSP settings*.

Loaded from disk.

3.3.1 Filter

The **Filter** tab shows the settings for the energy filter which measures the pulse height and for the trigger filter which detects pulses. The filtering principle is described in section 6. General rules of thumb for the following important parameters are:

1. The *energy filter flat top time* should be larger than the longest pulse rise time.
2. The *energy filter rise time* can be varied to balance the resolution and throughput. In general, energy resolution improves with the increase of energy filter rise time, up to an optimum when longer filters only add more noise into the measurement. The energy filter dead time TD is about $2 \times (T_{\text{rise}} + T_{\text{flat}})$, and the maximum throughput for Poisson statistics is $1/(TD \cdot e)$. For HPGe detectors, a rise time of 4-6 μ s and a flat top of 1 μ s are usually appropriate.
3. A longer *trigger filter rise time* averages more samples and thus allows setting lower thresholds without triggering on noise.
4. Typically the *threshold* should be set as low as possible, just above the noise level.

The remaining parameters are usually minor adjustments for fine tuning and otherwise can remain at the default values:

5. A longer *trigger filter flat top time* makes it easier to detect slow rising pulses.
6. Choose the smallest *energy filter range* that allows setting the optimum energy filter rise time. Larger filter ranges allow longer filter sums, but increase the granularity of possible values for the energy filter rise time and flat top time and increase the jitter of latching the energy filter output relative to the rising edge of the pulse. This is usually only important for very fast pulses.

3.3.2 Analog Signal Conditioning & Acquire ADC Traces

The **Analog Signal Conditioning** tab controls the analog gain, offset and polarity for each channel. It is useful to click on the **[Acquire ADC Traces]** button in the left control bar to view the signal that is read from the ADCs while adjusting these parameters (see Figure 3-3). The display shows all 16 channels of a module in 4 graphs of 4, and the sampling interval for each block can be set to capture a longer time frame. Click on the **[refresh]** button to update the graph.

Pulses from the detector should fall in the range of the ADC, e.g. from 0 to 4095 for a 12-bit ADC, with the baseline at ~10% of the ADC range (i.e. ~400) to allow for drifts, undershoots or mirror charges and no clipping at the upper limit. If there is clipping, adjust the *Gain* and *Offset* or click on the **[Adjust Offsets]** button to let the software set the DC offsets to proper levels automatically.

Since the trigger/filter circuits in the FPGA only act on rising pulses, negative pulses are inverted at the input of the FPGA, and the waveforms shown in the ADC trace display include this optional inversion. Thus, it is important to set the channel's *Polarity* such that pulses from the detector appear with positive amplitude (rising edge).

In the **ADC trace - single channel** tab, the ADC trace display also includes the option to view a FFT of the acquired trace. This is useful to diagnose noise contributions. Above the graph are controls for cursors and an option to change between linear and log scale. You can also save a trace to a text file using the *disk* symbol at the right.

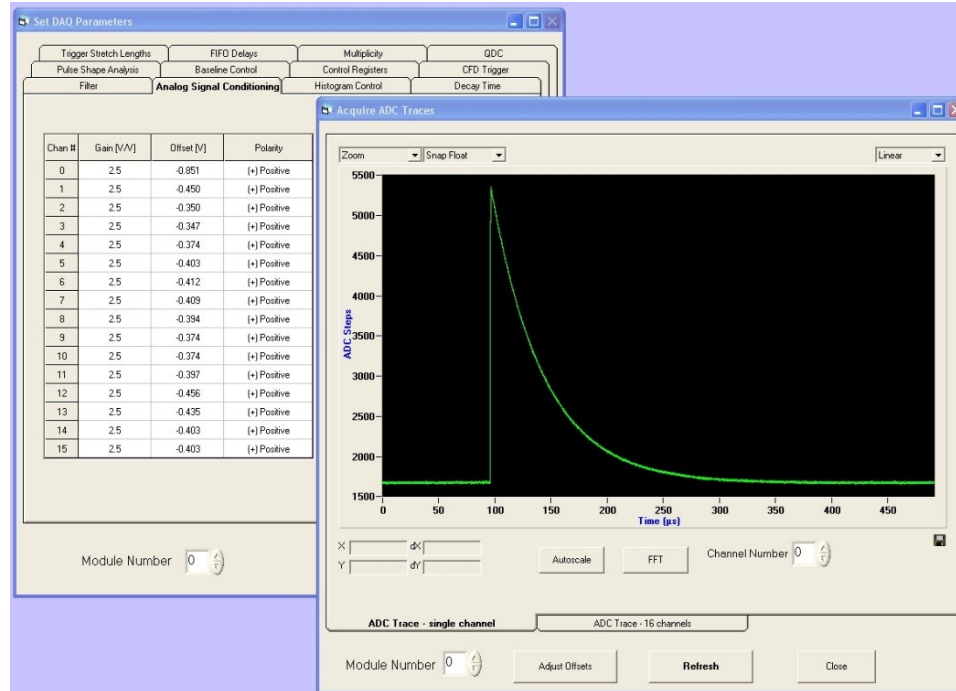

Figure 3-3: The Pixie-16 Set DAQ Parameters panel and ADC trace display.

3.3.3 Histogram Control

The *binning factor* in the **Histogram Control** tab controls the number of MCA bins in the spectrum. Energies are computed as 16-bit numbers, allowing in principle 64K MCA bins. However, spectrum memory for each channel is limited to 32K bins, so computed energy values are divided by $2^{\text{binning factor}}$ before building the histogram. *Binning factor* is usually set to 1, but for low count rates and wide peaks, it might be useful to set it to a larger value to obtain a spectrum with fewer bins, but more counts per bin.

Emin is reserved for a future function to subtract a constant “minimum energy” from the computed energy value before binning to essentially cut off the lower end of the spectrum.

3.3.4 Decay Time

As mentioned previously in section 2.4.2, a critical parameter for pulse energy computation is the signal *decay time* Tau. At high count rates, pulses overlap with each other at higher frequency. In order to compute the energy or pulse height of those pulses accurately without the need to wait until they decay back to baseline level completely, the pulse height computation algorithm implemented in the Pixie-16 uses the decay time to compute and remove the contribution from the exponentially decaying tail of the overlapping prior pulse when computing the pulse height of the current pulse.

It is assumed the pulses have only a single exponential decay constant. If pulses have multiple decay constants, it might be possible to use the decay constant that dominates the decay of the pulse, but the accuracy of pulse height computation will be degraded.

3.3.5 Pulse Shape Analysis

In the **Pulse Shape Analysis** tab, you can set the total *trace length* and the pre-trigger *trace delay* for the waveforms to be acquired in list mode runs. The *trace delay* cannot be longer

than the *trace length*, and for each Pixie-16 variant, there is also a limit for the maximum value of *trace delay* and *trace length*.

For the 500 MHz Pixie-16 modules, the ADCs are running at 500 MHz, but the traces are recorded with 100 MHz clocks in the FPGA with 5 ADC samples captured in each 10 ns interval. In addition, the data packing from the FPGA to the onboard External FIFO is two sets of 5 ADC samples in one transfer. So the *trace length* should be multiples of 20 ns, i.e., 20 ns, 40 ns, ... for instance, a trace length of 500 ns and a trace delay of 200 ns.

3.3.6 Baseline Control & Acquire Baselines

The Pixie-16 constantly takes baseline measurements when no pulse is detected and keeps a baseline average to be subtracted from the energy filter output during pulse height reconstruction. Baseline measurements that differ from the average by more than the *Baseline Cut* value will be rejected as they are likely contaminated with small pulses below the trigger threshold. A series of baseline measurements for each channel can be viewed by clicking on the **[Acquire Baseline]** button, and in the BASELINE - SINGLE CHANNEL panel a histogram of baselines can be built to verify that the *Baseline Cut* does not reject measurements falling into the main (ideally Gaussian) peak in the baseline distribution. Usually, it is sufficient to keep *Baseline Cut* at its default value.

Note: Since the baseline computation takes into account the exponential decay, no pulses should be noticeable in the baseline display if a) the decay time is set correctly and b) the detector pulses are truly exponential.

Baseline Percent is a parameter used for automatic offset adjustment; by clicking on the *Adjust Offsets* button, offsets will be set such that the baseline seen in the ADC trace display falls at the *Baseline Percent* fraction of the full ADC range (e.g. for a 12-bit ADC and *Baseline Percent* = 10% the baseline falls at ADC step 409 out of 4096 total).

3.3.7 Control Registers

The **Control Registers** tab sets a number of options affecting the module as a whole (Module Control Register B) or affecting each channel individually (Channel Control Register A):

Module Control Register B

Table 3-1 Descriptions of Module Control Register B

Bit name	Bit #	Description
MODCSRB_CPLDPULLUP	0	Enable pullups for PXI trigger lines on the backplane through an onboard CPLD. With the pullups, those PXI trigger lines default to logic high state. Only when one module actively pulls a line to logic low state will such a line be in the low state. Therefore signals transmitted over those PXI trigger lines are actively low signals Note: enable this bit only for one module per crate (e.g. the crate master module)
reserved	3:1	
MODCSRB_DIRMOD	4	Set this module as the Director module so that it can send triggers, trace and header DPM full signal and run synchronization signal to all crates through the rear I/O trigger modules. Here triggers include fast trigger and validation trigger

		Note: enable this bit only for one module among all crates (e.g. the system director module in multi-crate configuration)
reserved	5	
MODCSRB_CHASSISMASTER	6	Set this module as the chassis master module so that it can send triggers, trace and header DPM full signal and run synchronization signal to the backplane of the local crate. Here triggers include fast trigger and validation trigger Note: enable this bit only for one module per crate (e.g. the crate master module)
MODCSRB_GFTSEL	7	Select external fast trigger source (=1: external validation trigger, =0: external fast trigger, in case these two signals are swapped at the Pixie-16 front panel input connectors)
MODCSRB_ETSEL	8	Select external validation trigger source (=1: external fast trigger, =0: external validation trigger, in case these two signals are swapped at the Pixie-16 front panel input connectors)
reserved	9	
MODCSRB_INHIBITENA	10	Enable (=1) or disable (=0) the use of external INHIBIT signal. When enabled, the external INHIBIT signal in the logic high state will prevent the run from starting until this external INHIBIT signal goes to logic low state
MODCSRB_MULTCRATES	11	Set this module to run in the multi-crate mode (=1) or in the local-crate mode (=0). If the module is running in multi-crate mode, it will use the trace and header DPM full signal and run synchronization signal that are generated and distributed among multiple crates. If the module is running in local-crate mode, it will use the trace and header DPM full signal and run synchronization signal generated in the local crate
MODCSRB_SORTEVENTS	12	Sort (=1) or do not sort (=0) events from all 16 channels of a Pixie-16 module based on the timestamps of the events, before storing the events in the external FIFO Note: all 16 channels must have the same DAQ parameters setting to use this feature
MODCSRB_BKPLFASTTRIG	13	Enable (=1) or disable (=0) the sending of 16 local fast triggers to the 16 lines on the backplane of the crate Note: only one module can enable this option in each PCI bus segment of a crate (not limited to the crate master module, e.g. any module in each PCI bus segment)
reserved	31:14	

Channel Control Register A

Table 3-2 Descriptions of Channel Control Register A

Bit name	Bit #	Description
CCSRA_FTRIGSEL	0	Channel fast trigger selection (=1: module fast trigger from the System FPGA; =0: the selection depends on the value of another bit CCSRA_GROUPTRIGSEL – if CCSRA_GROUPTRIGSEL = 1, select the channel validation trigger from the System FPGA,

		and if <code>CCSRA_GROUPTRIGSEL = 0</code> , select this channel's local fast trigger)
CCSRA_EXTTRIGSEL	1	Module validation trigger selection (=1: module gate input from the Pixie-16 front panel Module Gate LVDS connector; =0: module validation trigger from the System FPGA)
CCSRA_GOOD	2	Set this channel as a Good channel (=1) or a not Good channel (=0). When a channel is set to be a not Good channel, it still generates local fast triggers, which could be used in multiplicity computation, etc., but this channel will not record list mode data or MCA data, and will not update its baseline value
CCSRA_CHANTRIGSEL	3	Channel validation signal selection (=1: channel gate input from the Pixie-16 front panel Channel Gate LVDS connector; =0: channel validation trigger from the System FPGA)
CCSRA_SYNCDATAACQ	4	Choose the level of synchronous data acquisition for this channel (=1: stops taking data when the trace or header DPM for any channel of any Pixie-16 module in the system is full; =0: stops taking data only when the trace or header DPM for this channel of this Pixie-16 module is full)
CCSRA_POLARITY	5	Choose this channel's input signal polarity (=1: invert input signal's polarity; =0: do not invert input signal's polarity). (Please note in Pixie-16, signal processing requires positive rising input signal. So if input signal has a negative falling edge, it should be inverted by setting this <code>CCSRA_POLARITY</code> bit to 1)
CCSRA_VETOENA	6	Enable (=1) or disable (=0) this channel's veto. If veto is enabled, this channel's fast trigger will be vetoed by either the module veto signal (see bit 20 <code>CCSRA_MODVETOSEL</code> below) or channel veto signal (see bit 19 <code>CCSRA_CHANVETOSEL</code> below). But if veto is disabled, this channel's fast trigger will not be vetoed by either veto signal, even if either veto signal is present
CCSRA_HISTOE	7	Enable (=1) or disable (=0) the histogramming of pulse energy values in the onboard MCA memory. However, the current Pixie-16 firmware always histograms pulse energy values in the onboard MCA memory. So this <code>CCSRA_HISTOE</code> is essentially not in use at the moment
CCSRA_TRACEENA	8	Enable (=1) or disable (=0) trace capture in the list mode run for this channel
CCSRA_QDCENA	9	Enable (=1) or disable (=0) QDC sums recording in the list mode run for this channel. There are a total of 8 QDC sums for each event
CCSRA_CFDMODE	10	Enable (=1) or disable (=0) CFD trigger in the list mode run for this channel. CFD trigger is used to latch sub-sample timing for the event time of arrival or timestamp
CCSRA_GLOBTRIG	11	Enable (=1) or disable (=0) the requirement of module validation trigger (see 3.3.11.5) for this channel. If enabled, only when module validation trigger overlaps the channel fast trigger will the events be recorded for this channel
CCSRA_ESUMSENA	12	Enable (=1) or disable (=0) the recording of raw energy sums and baseline values in the list mode run for this channel. There are a

		total of three raw energy sums and one baseline value for each event. Please note the baseline value is stored in the format of 32-bit IEEE float point (IEEE 754)
CCSRA_CHANTRIG	13	Enable (=1) or disable (=0) the requirement of channel validation trigger (see 3.3.11.4) for this channel. If enabled, only when channel validation trigger overlaps the channel fast trigger will the events be recorded for this channel
CCSRA_ENARELAY	14	Switch between two attenuations or gains for the input signal in this channel through an input relay (=1: close the input relay resulting in no input signal attenuation; =0: open the input relay resulting in a ¼ input signal attenuation)
CCSRA_PILEUPCTRL	15	Control normal pileup rejection (bit 15) and inverse pileup rejection (bit 16) for list mode runs: 1) Bits [16:15] = 00 , record all events 2) Bits [16:15] = 01 , only record single events, i.e., reject piled up events 3) Bits [16:15] = 10 , record everything for piled up events, but will not record trace for single events even if trace recording is enabled, i.e., only record event header 4) Bits [16:15] = 11 , only record piled up events, i.e., reject single events In all cases, if the event is piled up, no energy will be computed for such event
CCSRA_INVERSEPILEUP	16	
CCSRA_ENAENERGYCUT	17	Enable (=1) or disable (=0) the “no traces for large pulses” feature. If enabled, trace will be not be recorded if the event energy is larger than the value set in DSP parameter <i>EnergyLow</i>
CCSRA_GROUPTRIGSEL	18	Select channel fast trigger – this bit works together with the CCSRA_FTRIGSEL bit (bit 0): if CCSRA_FTRIGSEL= 1, this CCSRA_GROUPTRIGSEL bit has no effect; if CCSRA_FTRIGSEL= 0, then if CCSRA_GROUPTRIGSEL = 1, select the channel validation trigger from the System FPGA, and if CCSRA_GROUPTRIGSEL = 0, select this channel’s local fast trigger
CCSRA_CHANVETOSEL	19	Channel veto signal selection (=1: channel validation trigger from the System FPGA; =0: channel gate input from the Pixie-16 front panel Channel Gate LVDS connector)
CCSRA_MODVETOSEL	20	Module veto signal selection (=1: module validation trigger from the System FPGA; =0: module gate input from the Pixie-16 front panel Module Gate LVDS connector)
CCSRA_EXTTSENA	21	Enable (=1) or disable (=0) the recording of the 48-bit external clock timestamp in the event header during list mode run for this channel
reserved	31:22	

3.3.8 CFD Trigger

3.3.8.1 100 MHz and 250 MHz Pixie-16 modules

The following CFD algorithm is implemented in the signal processing FPGA of the 100 MHz (Rev. B, C, D and F) and 250 MHz (Rev. F) Pixie-16 modules. Assume the digitized waveform can be represented by data series $Trace[i]$, $i = 0, 1, 2, \dots$. First the fast filter response (FF) of the digitized waveform is computed as follows:

$$FF[i] = \sum_{j=i-(FL-1)}^i Trace[j] - \sum_{j=i-(2*FL+FG-1)}^{i-(FL+FG)} Trace[j] \quad (3-1)$$

Where FL is called the fast length and FG is called the fast gap of the digital trapezoidal filter. Then the CFD is computed as follows:

$$CFD[i + D] = FF[i + D] * (1 - w/8) - FF[i] \quad (3-2)$$

Where D is called the CFD delay length and w is called the CFD scaling factor ($w=0, 1, \dots, 7$).

The CFD zero crossing point (ZCP) is then determined when $CFD[i] \geq 0$ and $CFD[i+1] < 0$. The timestamp is latched at Trace point i , and the fraction time f is given by the ratio of the two CFD response amplitudes right before and after the ZCP.

$$f = \frac{CFDout1}{CFDout1 - CFDout2} \quad (3-3)$$

Where $CFDout1$ is the CFD response amplitude right before the ZCP, and $CFDout2$ is the CFD response amplitude right after the ZCP (subtraction is used in the denominator since $CFDout2$ is negative). The Pixie-16 DSP computes the CFD final value as follows and stores it in the output data stream for online or offline analysis.

$$CFD = \frac{CFDout1}{CFDout1 - CFDout2} \times N \quad (3-4)$$

Where N is scaling factor, which equals to 32768 for 100 MHz modules and 16384 for 250 MHz modules, respectively (see 4.2.3.1).

Figure 3-4 shows a sample ADC trace, its fast filter response and its CFD response, respectively. The top figure shows a raw ADC trace. After computing the fast filter response on the raw ADC trace using Equation 3-1, the fast filter response is compared against the fast filter threshold as shown in the middle figure. The ADC sample where the fast filter response crosses the fast filter threshold is called the fast trigger point, which also starts the search for the CFD zero crossing point. The CFD response is computed using Equation 3-2 and is shown in the bottom figure (for actual implementation in the firmware, the fast filter response FF is delayed slightly before being used for computing the CFD response so that there are sufficient number of CFD response points to look for the zero crossing point after the fast trigger). To prevent premature CFD trigger as a result of the noise in the CFD response before the actual trigger, a DSP parameter called $CFDThresh$ is used to suppress those noise-caused zero crossing. However, if a zero crossing point cannot be found within a certain period after the fast trigger (typically 32 clock cycles), e.g., due to unnecessarily high $CFDThresh$, a forced CFD Trigger will be issued and a flag will be set in an event header word to indicate that the recorded CFD time for this event is invalid. However, the event will still have a valid timestamp which is latched by the fast filter

trigger when fast filter crosses over the trigger threshold. The aforementioned CFD parameters correspond to the following DSP parameters.

Table 3-3 Corresponding DSP Parameters for the CFD Parameters

CFD Parameters	DSP Parameters
FL	FastLength
FG	FastGap
Fast Filter Threshold	FastThresh
D	CFDDelay
W	CFDScale (valid values: 0, 1, 2, ... and 7)
CFD Threshold	CFDThresh

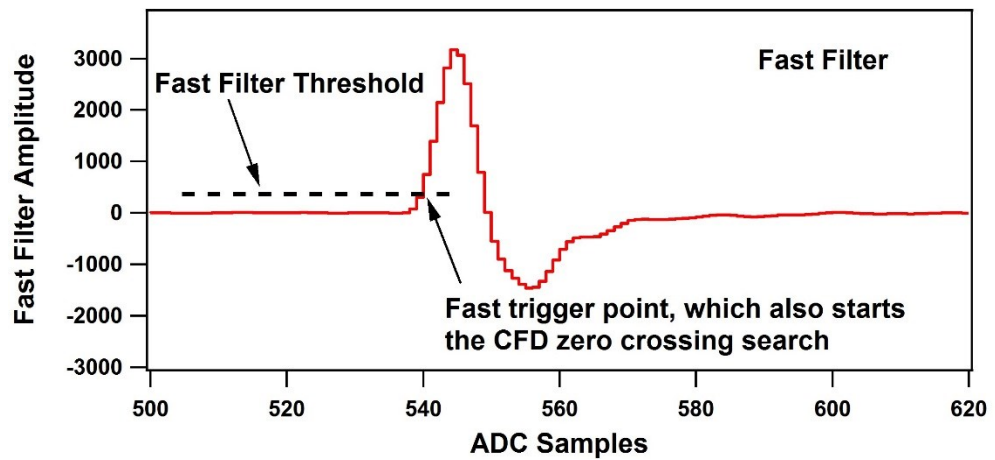
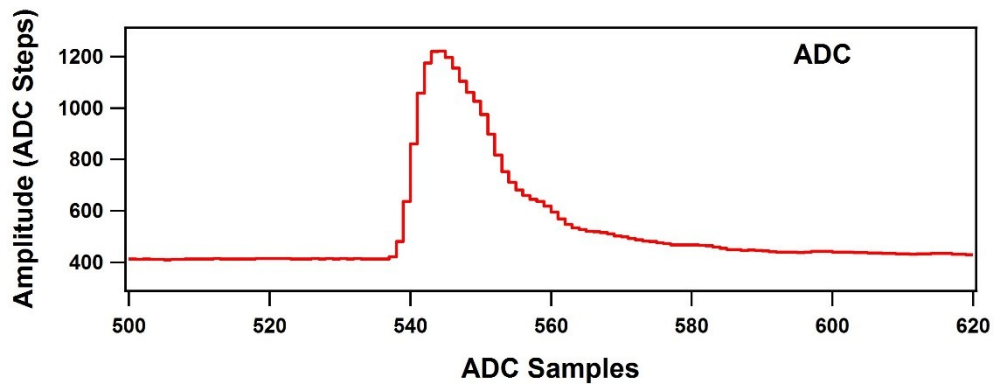

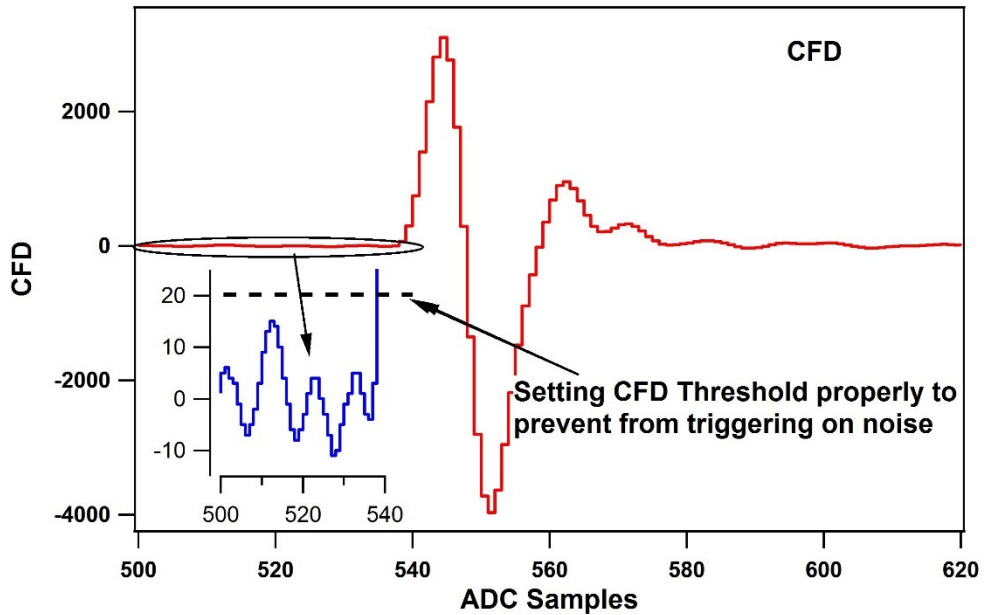

Figure 3-4: Illustration of the Pixie-16 CFD algorithm

In the 250 MHz Pixie-16 modules, the event timestamp is counted with 125 MHz clock ticks, i.e., 8 ns intervals, and two consecutive 250 MHz ADC samples are captured in one 8 ns interval as well. The CFD trigger also runs at 125 MHz, but the CFD zero crossing point is still reported as a fractional time between two neighboring 250 MHz ADC samples, which are processed by the FPGA in one 125 MHz clock cycle. However, the CFD zero crossing point could be in either the odd or even clock cycle of the captured 250 MHz ADC waveforms. Therefore, the firmware outputs a "CFD trigger source" bit in the output data stream to indicate whether the CFD zero crossing point is in the odd or even clock cycle of the captured 250 MHz ADC waveforms.

In the 100 MHz Pixie-16 modules, event timestamp, CFD trigger, and ADC waveform capture are all carried out with the same 100 MHz clock. So there is no need to report "CFD trigger source" for the 100 MHz Pixie-16 modules.

3.3.8.2 500 MHz Pixie-16 modules

The CFD algorithm discussed in the previous section for the 100 MHz and 250 MHz Pixie-16 modules can also be written in the following format:

$$CFD(k) = w \cdot \left(\sum_{i=k}^{k+L} a(i) - \sum_{i=k-B}^{k-B+L} a(i) \right) - \left(\sum_{i=k-D}^{k-D+L} a(i) - \sum_{i=k-D-B}^{k-D-B+L} a(i) \right) \quad (3-5)$$

Where $a(i)$ is the ADC trace data, k is the index, and w , B , D , and L are CFD parameters.

The CFD algorithm implemented in the 500 MHz Pixie-16 modules is special when compared to the one implemented in the 100 MHz and 250 MHz Pixie-16 modules in terms of the ability to adjust parameters w , B , D , and L . The reason for this is that in the 500 MHz Pixie-16 modules, ADC data that come into the FPGA at the speed of 500 MHz is first slowed down with a ratio of 1:5, in other words, the FPGA captures 5 ADC samples at the rate of 100 MHz, i.e., every 10 ns. The FPGA then tries to find the CFD trigger point between any two adjacent 2-ns ADC samples within that 10 ns by first building sums of

ADC samples and then calculating differences between delayed and non-delayed sums until the zero crossing point is found. However, in the 500 MHz Pixie-16 modules, the FPGA does not have enough resources to build sums for 5 ADC samples in parallel with variable delays. Therefore, the CFD algorithm for the 500 MHz modules was implemented using a set of fixed CFD parameters as shown in Table 3-4. Tests show these fixed parameters give best performance for LaBr₃(Ce) detectors.

Table 3-4 Fixed CFD Parameter Values for 500 MHz Pixie-16 Modules

CFD Parameters	Fixed Values for 500 MHz Modules
w	1
B	5
D	5
L	1

The CFD time given by the 500 MHz Pixie-16 modules consists of two parts: a shift within the 5 ADC samples and a fractional time between two ADC samples where the CFD zero crossing occurred. The shift within the 5 ADC samples is reported as the 3-bit CFD trigger source [2:0] is defined as follows.

Table 3-5 Meanings of the CFD Trigger Source for 500 MHz Pixie-16 Modules

CFD Trigger Source [2:0]	Zero Crossing Point (ZCP) Location
000	ZCP occurred between the 5th ADC sample of the previous 5-sample group and the 1st ADC sample of the current 5-sample group
001	ZCP occurred between the 1th ADC sample of the current 5-sample group and the 2nd ADC sample of the current 5-sample group
010	ZCP occurred between the 2nd ADC sample of the current 5-sample group and the 3rd ADC sample of the current 5-sample group
011	ZCP occurred between the 3rd ADC sample of the current 5-sample group and the 4th ADC sample of the current 5-sample group
100	ZCP occurred between the 4th ADC sample of the current 5-sample group and the 5th ADC sample of the current 5-sample group
101	Not used
110	Not used
111	CFD trigger is forced, so CFD time is invalid

The CFD fractional time is given as follows.

$$CFD = \frac{CFDout1}{CFDout1 - CFDout2} \times 8192 \quad (3-6)$$

3.3.9 Trigger Stretch Lengths

External trigger stretch is used to stretch the module validation trigger pulse. Only relevant when module validation is required by setting bit CCSRA_GLOBTRIG.

Channel trigger stretch is used to stretch the channel validation trigger pulse. Only relevant when channel validation is required by setting bit CCSRA_CHANTRIG.

Veto stretch is used to stretch the veto pulse for this channel.

Fast trigger backplane length is used to stretch the fast trigger pulse to be sent to the System FPGA, where this fast trigger can be sent to the backplane to be shared with other modules, or can be used for making coincidence or multiplicity triggers.

3.3.10 FIFO Delays

External delay length is used to delay the incoming ADC waveform and the local fast trigger in order to compensate for the delayed arrival of the external trigger pulses, e.g., module validation trigger, channel validation trigger, etc.

Fast trigger backplane delay is used to delay the fast trigger pulse before it is sent to the System FPGA for sharing with other modules through the backplane or making coincidence or multiplicity triggers.

Table 3-6 Range for Trigger Stretch Lengths and FIFO Delays in Pixie-16 Modules

Parameters	Label	Range	
		100 or 500 MHz	250 MHz
<i>External trigger stretch</i>	④	0.01 – 40.95 μ s	0.008 – 32.76 μ s
<i>Channel trigger stretch</i>	⑤	0.01 – 40.95 μ s	0.008 – 32.76 μ s
<i>Veto stretch</i>	⑥	0.01 – 40.95 μ s	0.008 – 32.76 μ s
<i>Fast trigger backplane length</i>	①	0.01 – 40.95 μ s	0.008 – 32.76 μ s
<i>External delay length</i>	③	0 – 2.55 μ s (Rev. B/C/D) 0 – 5.11 μ s (Rev. F)	0 – 4.088 μ s
<i>Fast trigger backplane delay</i>	②	0 – 2.55 μ s (Rev. B/C/D) 0 – 5.11 μ s (Rev. F)	0 – 4.088 μ s

Figure 3-5 illustrates the signal processing in the Pixie-16 modules. The Trigger Stretch Lengths and FIFO Delays discussed above are shown in number 1 to 6 in the figure.

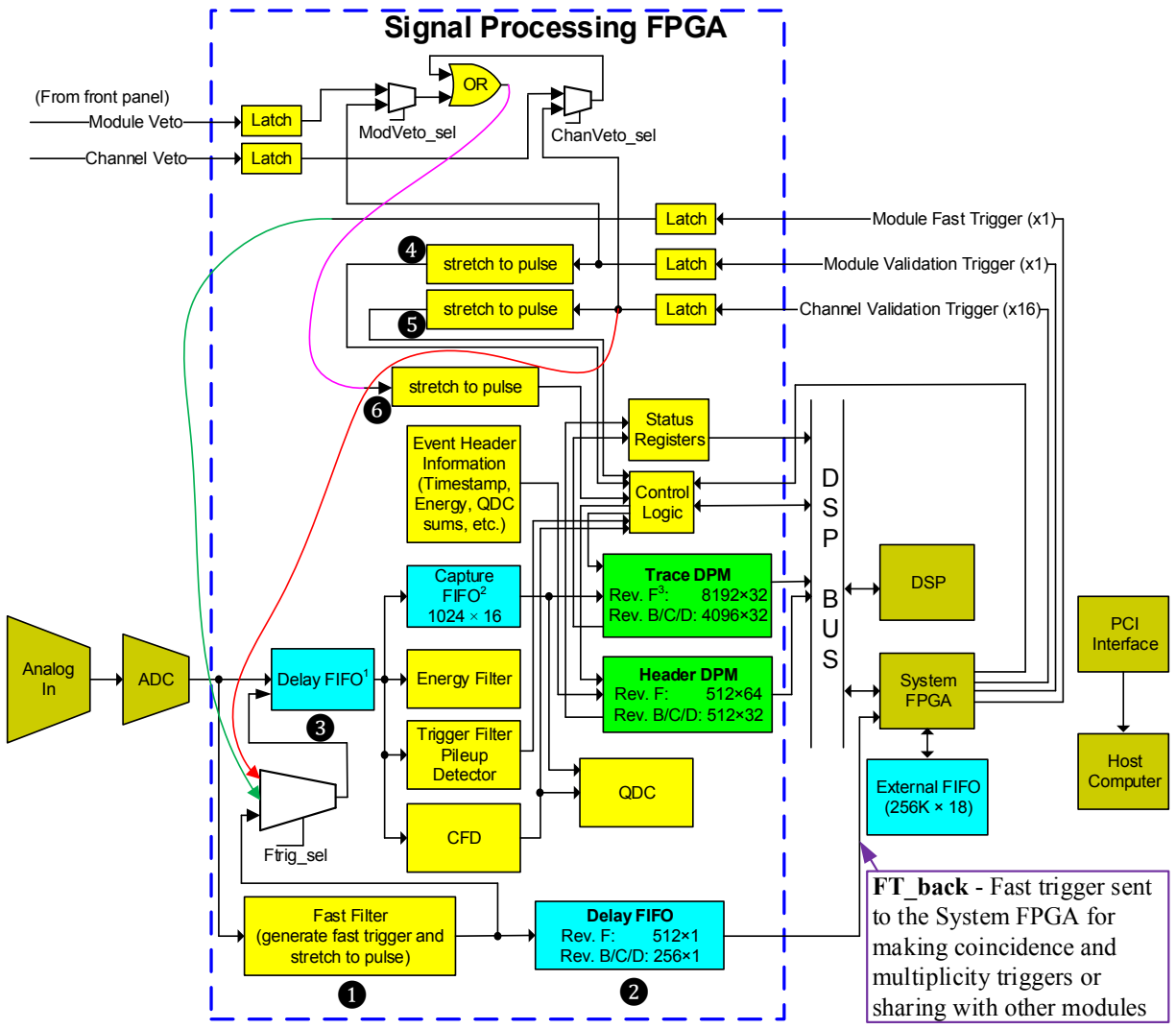

- ① - Fast trigger backplane length (FastTrigBackLen)
 - ② - Fast trigger backplane delay (FtrigoutDelay)
 - ③ - Extern delay length (ExternDelayLen)
 - ④ - External trigger stretch length (ExtTrigStretch)
 - ⑤ - Channel trigger stretch length (ChanTrigStretch)
 - ⑥ - Veto stretch (VetoStretch)
- ¹For the **Delay FIFO** to set the **extern delay length**, its length is either 2.55 μ s (Rev. B/C/D) or 5.11 μ s (Rev. F, 100 MHz) or 4.088 μ s (Rev. F, 250 MHz) or 5.11 μ s (Rev. F, 500 MHz)
- ²For 250 MHz Pixie-16, **Capture FIFO**'s size is 1024x32, and For 500 MHz Pixie-16, **Capture FIFO**'s size is 1024x72
- ³For Rev. F Pixie-16, 500 MHz modules' **Trace DPM** size is 8192x36. Others' is 8192x32

Ftrig_sel --
 CHANCSRA[0] = 1: use latched module fast trigger
 CHANCSRA[0] = 0 & CHANCSRA[18] = 1: use latched channel validation trigger
 CHANCSRA[0] = 0 & CHANCSRA[18] = 0: use local fast trigger

ChanVeto_sel --
 CHANCSRA[19] = 1: use Channel Validation Trigger from System FPGA
 CHANCSRA[19] = 0: use Channel Veto from front panel

ModVeto_sel --
 CHANCSRA[20] = 1: use Module Validation Trigger from System FPGA
 CHANCSRA[20] = 0: use Module Veto from front panel

Figure 3-5: Illustration of the signal processing in the Pixie-16

As shown in Figure 3-5, the incoming analog pulse is first digitized by the ADC and then enters the signal processing circuitries in the Signal Processing FPGA, each of which processes ADC data from 4 channels of a Pixie-16 module. The digitized data stream is first fed into two branches: a fast filter generating fast triggers to be sent to the System FPGA and a Delay FIFO which could be used to compensate for the delay between fast triggers and the external triggers. The digitized data stream passing through the Delay FIFO is then branched into four parts: 1) energy filter which samples energy running sums at the *PeakSample* time; 2) trigger filter which detects pulse and performs pileup inspection; 3) capture FIFO which delays the ADC data according to the *trace delay* parameter value before the ADC data is streamed into the Trace Dual Port Memory (DPM) when a valid pulse is detected; and 4) CFD circuitry where a CFD trigger is generated to trigger the computation of QDC sums, latch timestamps and record traces. The Control Logic in the signal processing FPGA utilizes the local fast trigger, CFD trigger, veto and external triggers to determine whether and when to stream waveform data into the Trace DPM and to write event information into the Header DPM. The DSP polls the status of the DPMs through the Status Registers and moves event data into the External FIFO through the DSP bus and the System FPGA.

Figure 3-5 also describes the selections for channel fast trigger, channel veto and module veto signals, which were discussed earlier in section 3.3.7 (Channel Control Register A).

3.3.11 Multiplicity and Coincidence

3.3.11.1 Illustrations of Multiplicity, Coincidence and Group Triggers

Multiplicity or coincidence can be checked within one Pixie-16 module and/or its immediate neighbors (i.e., no slot gap in between) to decide whether or not to accept an event. To ensure maximal flexibility when specifying how multiplicity or coincidence is checked, two schemes for forming 16 different multiplicity or coincidence groups within one Pixie-16 module were implemented and shown in Figure 3-6 and Figure 3-7, respectively.

Fast triggers generated within each of the 16 channels of a Pixie-16 module can be distributed to its immediate neighbors through the PXI backplane. Thus a group of up to 48 fast trigger signals can be formed within one Pixie-16 module by combining all fast triggers from the module itself and its two immediate neighbors. Furthermore, up to 16 such groups can be formed within one Pixie-16 module, and each group can have each of its 48 fast trigger signals enabled or disabled by using a user defined contribution mask (48-bit). However, if more than 3 Pixie-16 modules are required to participate in the multiplicity or coincidence computation, a custom firmware is most likely needed. Please contact XIA for more information.

It should be pointed out that two neighboring modules have to share 16 nearest neighbor lines between them, i.e., if for instance one module sends fast triggers of 5 of its channels to its left neighbor module, its left neighbor module can then only send fast triggers of 11 of its channels to its right neighbor module, i.e., the former module itself. Therefore, it should be very careful when arranging groups of multiplicity or coincidence to ensure that there will be no bus contention on the backplane.

Figure 3-8 shows that four group triggers can also be generated within one Pixie-16 module. Similar to the multiplicity or coincidence triggers, one module can use up to 48 fast trigger signals from the module itself and two of its immediate neighbors and select one of them as the group trigger for a group of 4 channels. Thus a total of 4 group triggers

can be generated in one Pixie-16 module and they can be used as channel validation triggers, which will be discussed further below.

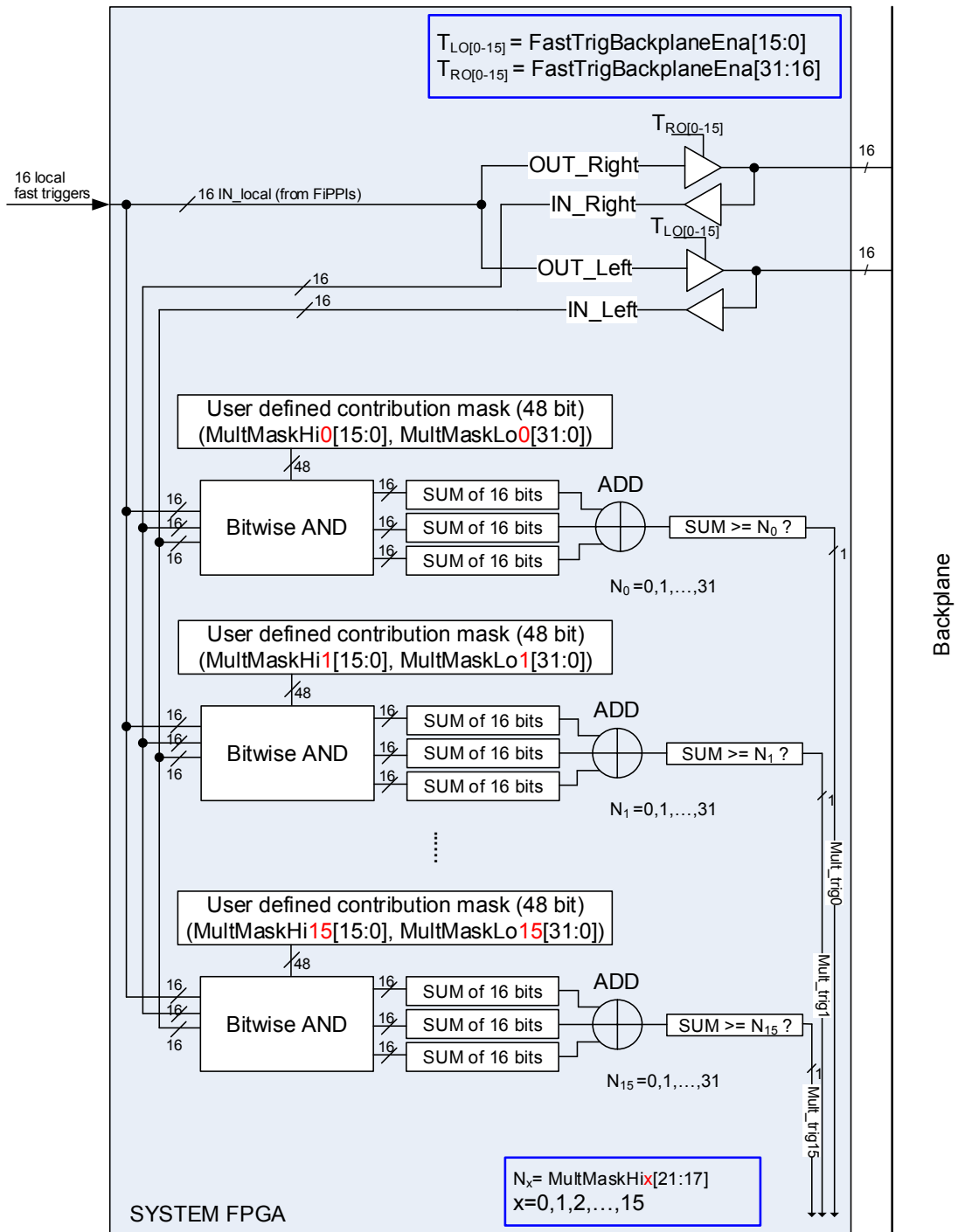

Figure 3-6: Illustration of the Multiplicity Trigger in the Pixie-16

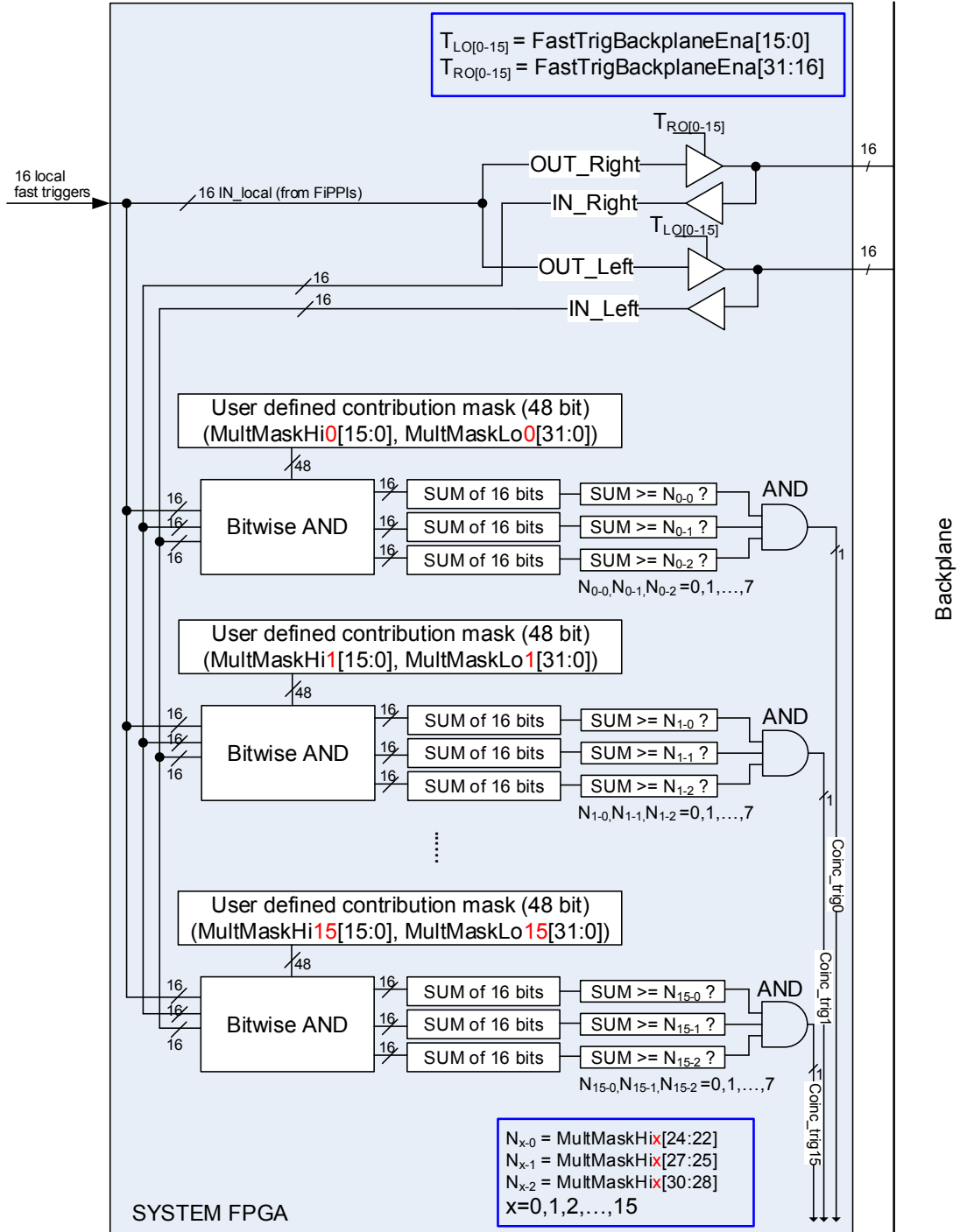

Figure 3-7: Illustration of the Coincidence Trigger in the Pixie-16

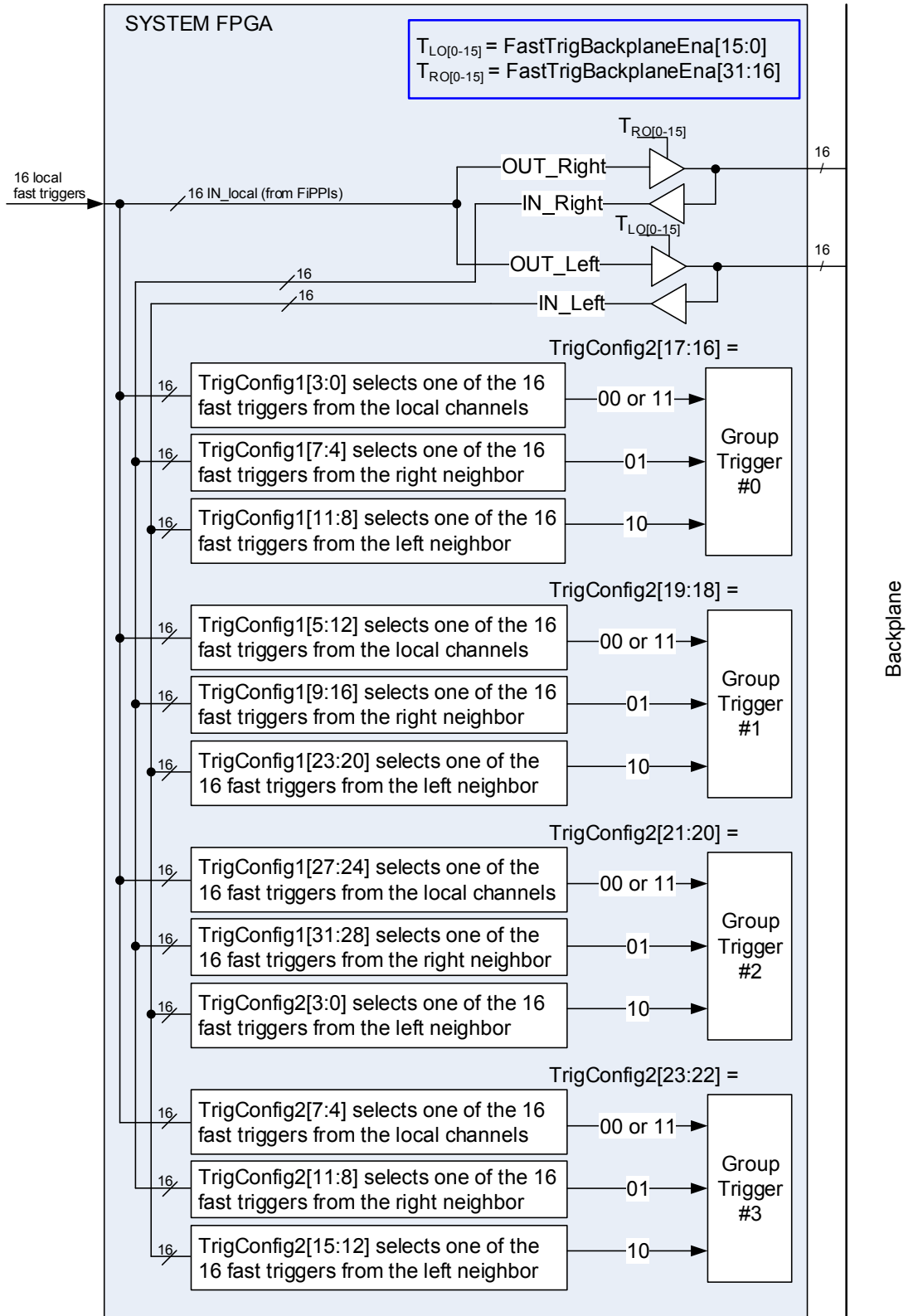

Figure 3-8: Illustration of the Group Trigger in the Pixie-16

3.3.11.2 Parameters for Configuring Multiplicity, Coincidence and Group Triggers

The user defined 48-bit contribution mask used for multiplicity trigger, coincidence trigger or group trigger is defined by the two parameters, *Multiplicity Mask Low* and *Multiplicity Mask High*. The definitions of the bits of these two parameters are shown in Table 3-7.

Table 3-7 Definitions of Multiplicity Parameters

Multiplicity Parameters	Description
Multiplicity Mask Low[15:0]	User defined 48-bit contribution mask [15:0] (masking fast triggers from the module itself)
Multiplicity Mask Low[31:16]	User defined 48-bit contribution mask [31:16] (masking fast triggers from the module's right side neighbor)
Multiplicity Mask High[15:0]	User defined 48-bit contribution mask [47:32] (masking fast triggers from the module's left side neighbor)
Multiplicity Mask High[16]	Select either multiplicity trigger (=1) or coincidence trigger (=0) as the source of the channel validation trigger
Multiplicity Mask High[21:17]	5-bit threshold for this channel's multiplicity trigger
Multiplicity Mask High[24:22]	3-bit threshold for this channel's 1 st group of 16-bit coincidence trigger (the module itself)
Multiplicity Mask High[27:25]	3-bit threshold for this channel's 2 nd group of 16-bit coincidence trigger (the module's right side neighbor)
Multiplicity Mask High[30:28]	3-bit threshold for this channel's 3 rd group of 16-bit coincidence trigger (the module's left side neighbor)
Multiplicity Mask High[31]	Select group trigger/external fast trigger (=1) or multiplicity/coincidence trigger (=0) as the source of the channel validation trigger

The *Fast trigger nearest neighbor enable* parameter, or *FastTrigBackplaneEna*, controls whether or not to send the module's 16 local fast triggers to its immediate left or right side neighbors. For each Pixie-16 module, there are a total of 16 nearest neighbor bus lines on the backplane to the left side slot, and also a total of 16 nearest neighbor bus lines on the backplane to the right side slot (except for the leftmost slot or rightmost slot in the Pixie-16 crate). However, each set of the 16 nearest neighbor bus lines are shared between those two neighboring modules, in other words, each of the 16 lines can only be driven by one of the two modules. Table 3-8 shows the definitions of the *Fast trigger nearest neighbor enable* parameter.

Table 3-8 Definitions of Fast Trigger Nearest Neighbor Enable

FastTrigBackplaneEna	Description
FastTrigBackplaneEna [15:0]	Controls whether or not to send the module's 16 local fast triggers to its immediate left side neighbor. For instance, if FastTrigBackplaneEna[0] = 1, channel 0's fast trigger will be sent to the left side neighbor module. However, if this bit is 0, then channel 0's fast trigger will be not sent to the left side neighbor module
FastTrigBackplaneEna [31:16]	Controls whether or not sending the module's 16 local fast triggers to its immediate right side neighbor. For instance, if FastTrigBackplaneEna[16] = 1, channel 0's fast trigger will be sent to the right side neighbor module. However, if this bit is 0, then channel 0's fast trigger will be not sent to the right side neighbor module

On the same **Multiplicity** tab, there are also four trigger configuration register parameters, *TrigConfig0*, *TrigConfig1*, *TrigConfig2* and *TrigConfig3*. These trigger configuration

registers are used by the firmware to allow the users to select different operation modes in the firmware. For instance, the group triggers discussed earlier use TrigConfig1 and TrigConfig2 to select a fast trigger from one of those 48 fast triggers to be the group trigger. Below, trigger configuration registers TrigConfig0, TrigConfig1 and TrigConfig2 are defined with details in Table 3-9, Table 3-10, and Table 3-11, respectively. TrigConfig3 is not in use currently, so it is not defined.

Table 3-9 Definitions of TrigConfig0 Bits

Bits	Description
[3:0]	Select source signal for the internal fast trigger (Int_FastTrig_Sel) from one of the 16 local channel fast triggers
[7:4]	Select external fast trigger (Ext_FastTrig_In) from one of the five sources: 0 Ext_FastTrig_Sel, 1 Int_FastTrig_Sel, 2 FTIN_Or, 3 LVDS_FastTrig_FP 4 ChanTrig_Sel
[11:8]	Select source signal for the internal validation trigger (Int_ValidTrig_Sel) from one of the 16 local channel fast triggers
[14:12]	Select one of the two groups of test signals to send to the digital outputs for test/debug purpose on the Pixie-16 front panel (see Table 1-11). Valid values: 000 and 001
[15]	Enable (=1) or disable (=0) the sending of test signals to the digital outputs for test/debug purpose on the Pixie-16 front panel
[19:16]	Select one of the 16 local channels' test signals to send to the digital outputs for test/debug purpose on the Pixie-16 front panel (see Table 1-11)
[23:20]	Select source signal for the 6 th output of the digital outputs for test/debug purpose on the Pixie-16 front panel 0 ET_in 1 FT_in 2 DPMfull_BP 3 sync_rdy_all 4 ext_fasttrig_fp 5 lvds_fasttrig_fp 6 ext_validtrig_fp 7 lvds_validtrig_fp 8 chantrig_or
[25:24]	Select module fast trigger from one of the four sources: 0 Ext_FastTrig_In, 1 FT_LocalCrate_BP, 2 FT_In_BP 3 FT_WiredOr
[27:26]	Select module validation trigger from one of the four sources: 0 Ext_ValidTrig_In, 1 ET_LocalCrate_BP, 2 ET_In_BP 3 ET_WiredOr
[31:28]	Select external validation trigger (Ext_ValidTrig_In) from one of the five sources: 0 Ext_ValidTrig_Sel, 1 Int_ValidTrig_Sel, 2 FTIN_Or, 3 LVDS_ValidTrig_FP 4 ChanTrig_Sel

Table 3-10 Definitions of TrigConfig1 Bits

Bits	Description
[3:0]	Group trigger #0_0: select one of the 16 fast triggers from the local channels based on the value of these 4 bits
[7:4]	Group trigger #0_1: select one of the 16 fast triggers from the right neighbor based on the value of these 4 bits
[11:8]	Group trigger #0_2: select one of the 16 fast triggers from the left neighbor based on the value of these 4 bits
[15:12]	Group trigger #1_0: select one of the 16 fast triggers from the local channels based on the value of these 4 bits
[19:16]	Group trigger #1_1: select one of the 16 fast triggers from the right neighbor based on the value of these 4 bits
[23:20]	Group trigger #1_2: select one of the 16 fast triggers from the left neighbor based on the value of these 4 bits
[27:24]	Group trigger #2_0: select one of the 16 fast triggers from the local channels based on the value of these 4 bits
[31:28]	Group trigger #2_1: select one of the 16 fast triggers from the right neighbor based on the value of these 4 bits

Table 3-11 Definitions of TrigConfig2 Bits

Bits	Description
[3:0]	Group trigger #2_2: select one of the 16 fast triggers from the left neighbor based on the value of these 4 bits
[7:4]	Group trigger #3_0: select one of the 16 fast triggers from the local channels based on the value of these 4 bits
[11:8]	Group trigger #3_1: select one of the 16 fast triggers from the right neighbor based on the value of these 4 bits
[15:12]	Group trigger #3_2: select one of the 16 fast triggers from the left neighbor based on the value of these 4 bits
[17:16]	Select Group trigger #0 from one of the Group trigger #0_0, Group trigger #0_1 and Group trigger #0_2, based on the value of these 2 bits
[19:18]	Select Group trigger #1 from one of the Group trigger #1_0, Group trigger #1_1 and Group trigger #1_2, based on the value of these 2 bits
[21:20]	Select Group trigger #2 from one of the Group trigger #2_0, Group trigger #2_1 and Group trigger #2_2, based on the value of these 2 bits
[23:22]	Select Group trigger #3 from one of the Group trigger #3_0, Group trigger #3_1 and Group trigger #3_2, based on the value of these 2 bits
[24]	Select either group trigger #0 or external fast trigger (gated by this channel's local fast trigger) as one of the two sources for the channel validation trigger for channels 0 - 3
[25]	Select either group trigger #1 or external fast trigger (gated by this channel's local fast trigger) as one of the two sources for the channel validation trigger for channels 4 - 7
[26]	Select either group trigger #2 or external fast trigger (gated by this channel's local fast trigger) as one of the two sources for the channel validation trigger for channels 8 - 11
[27]	Select either group trigger #3 or external fast trigger (gated by this channel's local fast trigger) as one of the two sources for the channel validation trigger for channels 12 - 15
[31:28]	Select channel trigger (ChanTrig_Sel) from one of the 16 channel validation triggers

3.3.11.3 Local Fast Trigger Gated by External Fast Trigger

In addition to the multiplicity, coincidence or group triggers, one more trigger that is of interest to users is the local fast trigger that is gated by external fast trigger. Figure 3-9 illustrates this *ExtFT_and_LocalFT* trigger. FT0 to FT15 are the 16 local fast triggers from the 16 channels of the Pixie-16 module, and the pulse width and delay of each of them can be adjusted using parameters *fast trigger backplane length* and *fast trigger backplane delay*, respectively, as discussed in sections 3.3.9 and 3.3.10. These local fast triggers are then individually gated by the *Ext_FastTrig_In* signal, which is the external fast trigger signal and is described in a later section (see Figure 3-17). The resulting triggers, *ExtFT_and_LocalFT_x* ($x=0, 1, \dots, 15$), can then be selected as channel validation trigger.

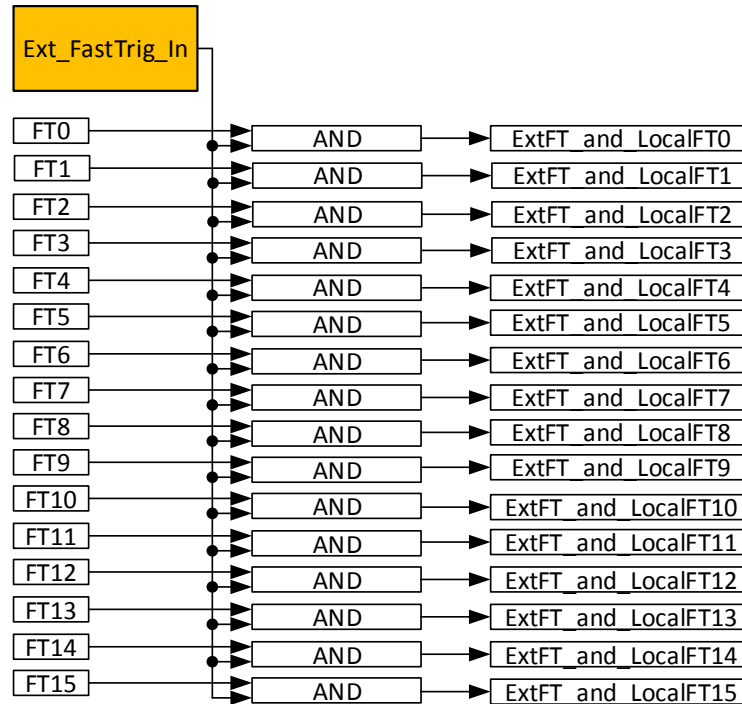

Figure 3-9: Local fast trigger gated by external fast trigger

3.3.11.4 Channel Validation Triggers

The channel validation trigger for each of the 16 local channels of the Pixie-16 module can be selected from the aforementioned four types of triggers: multiplicity trigger, coincidence trigger, group trigger and local fast trigger gated by the external fast trigger. The selection of which type of triggers for each channel is controlled by the parameters *Multiplicity Mask High* and *TrigConfig2*, as illustrated in Figure 3-10, Figure 3-11, Figure 3-12 and Figure 3-13.

As also illustrated in Figure 3-5, the channel validation trigger is generated in the System FPGA, and then sent to the Signal Processing FPGA, where it is first latched as a single clock cycle pulse, and then stretched to a pulse whose width is set by the parameter *channel trigger stretch length*. If channel validation trigger requirement is enabled for the channel, i.e., bit *CCSRA_CHANTRIG* of the Channel Control Register A is set to 1 (Table 3-2), only when the channel fast trigger overlaps with the channel validation trigger will the event be recorded for this channel. Due to the possible delay between the channel fast trigger and channel validation trigger, it might be necessary to adjust the *external delay length* (section 3.3.10) and/or *channel trigger stretch length*.

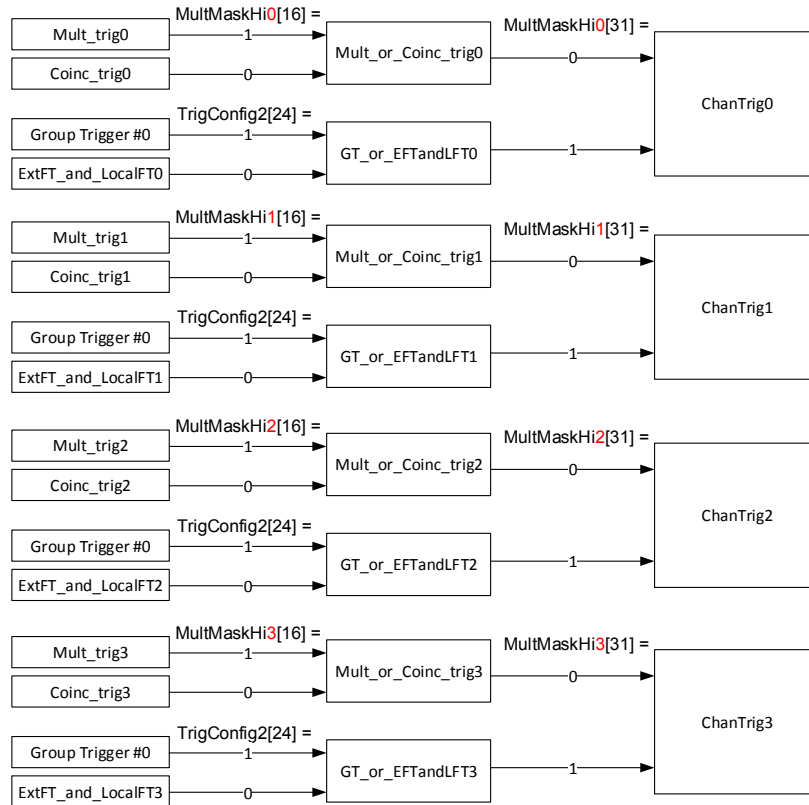

Figure 3-10: The selection for channel validation trigger for channels 0 to 3

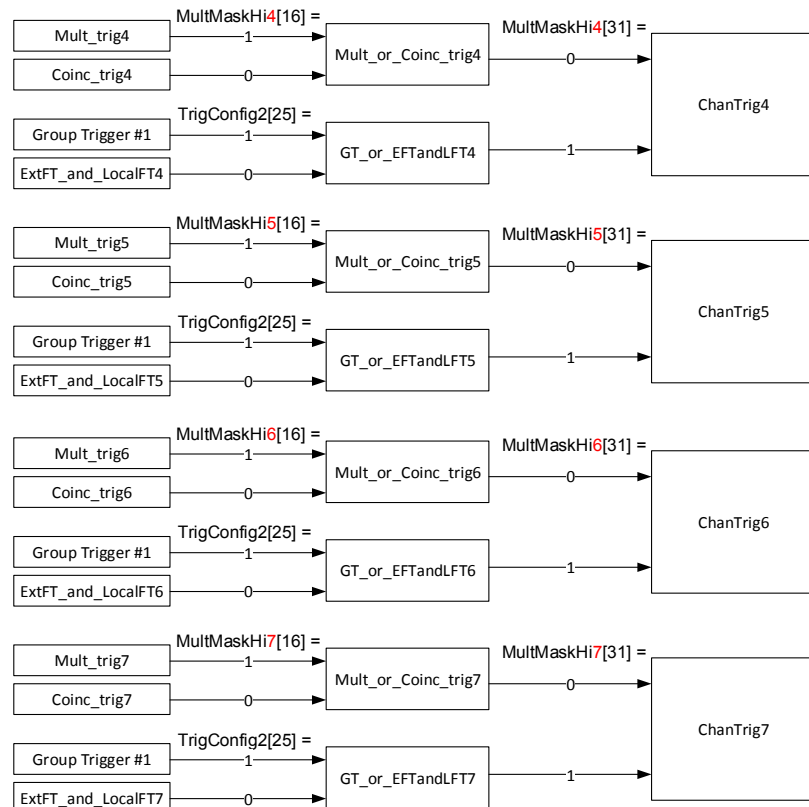

Figure 3-11: The selection for channel validation trigger for channels 4 to 7

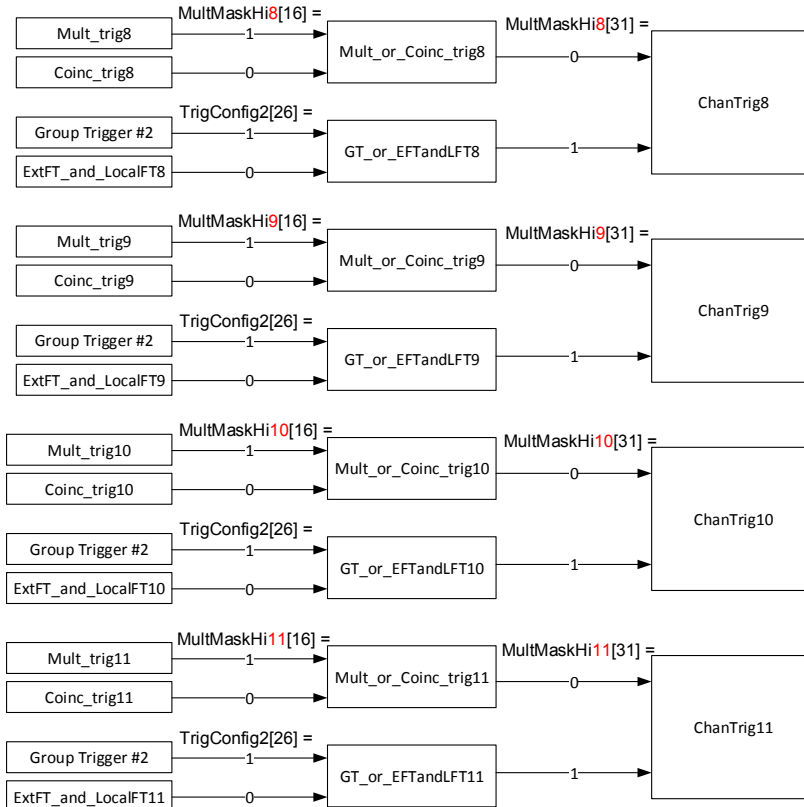

Figure 3-12: The selection for channel validation trigger for channels 8 to 11

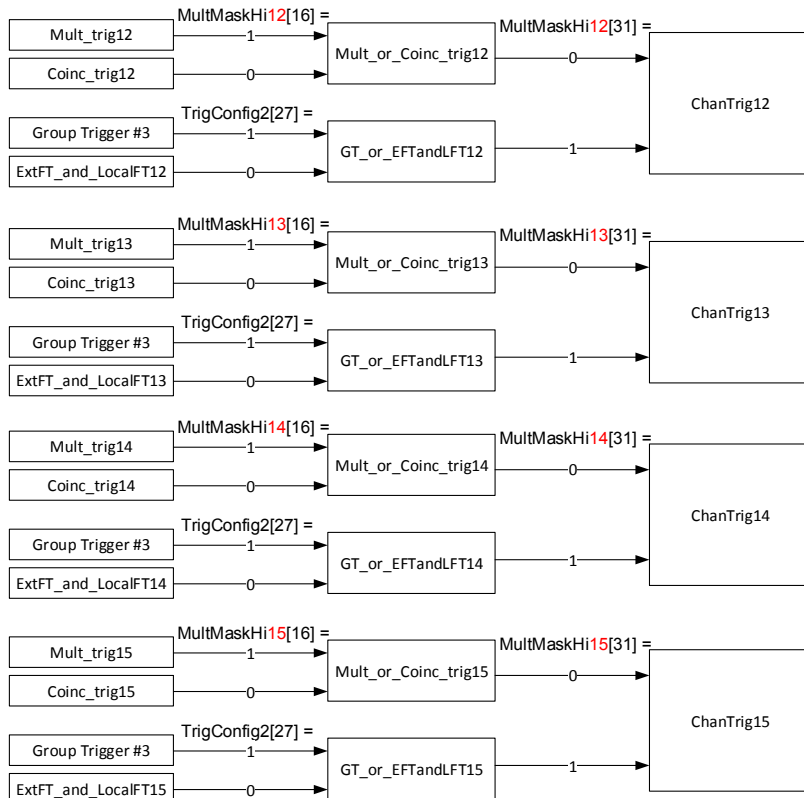

Figure 3-13: The selection for channel validation trigger for Channels 12 to 15

3.3.11.5 Module Validation Trigger

Similar to the channel validation trigger, the module validation trigger can also come from a variety of sources. Figure 3-14 and Figure 3-15 illustrate the four sources for generating the module validation trigger and how to choose each of the four sources. The selections are made through those three parameters *ModCSRB*, *TrigConfig0* and *TrigConfig2*. The *Ext_ValidTrig_Sel* signal shown in Figure 3-14 comes from the front panel digital I/O Connectors B and C ports in Rev. F modules, and for Rev. B/C/D modules, such *Ext_ValidTrig_Sel* signal comes from the same FI0 or FI4 port but at different I/O connectors.

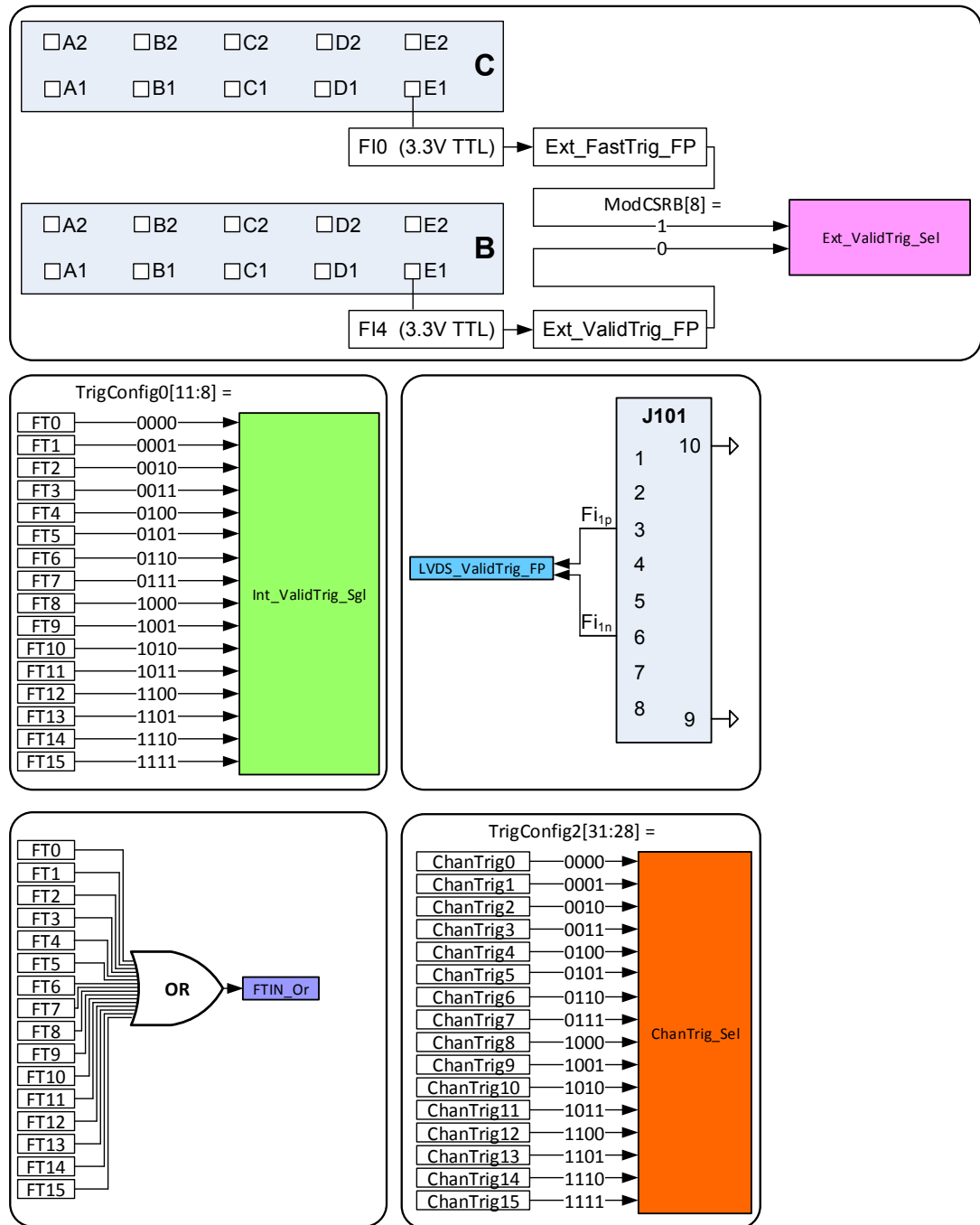

Figure 3-14: The sources for the external validation trigger

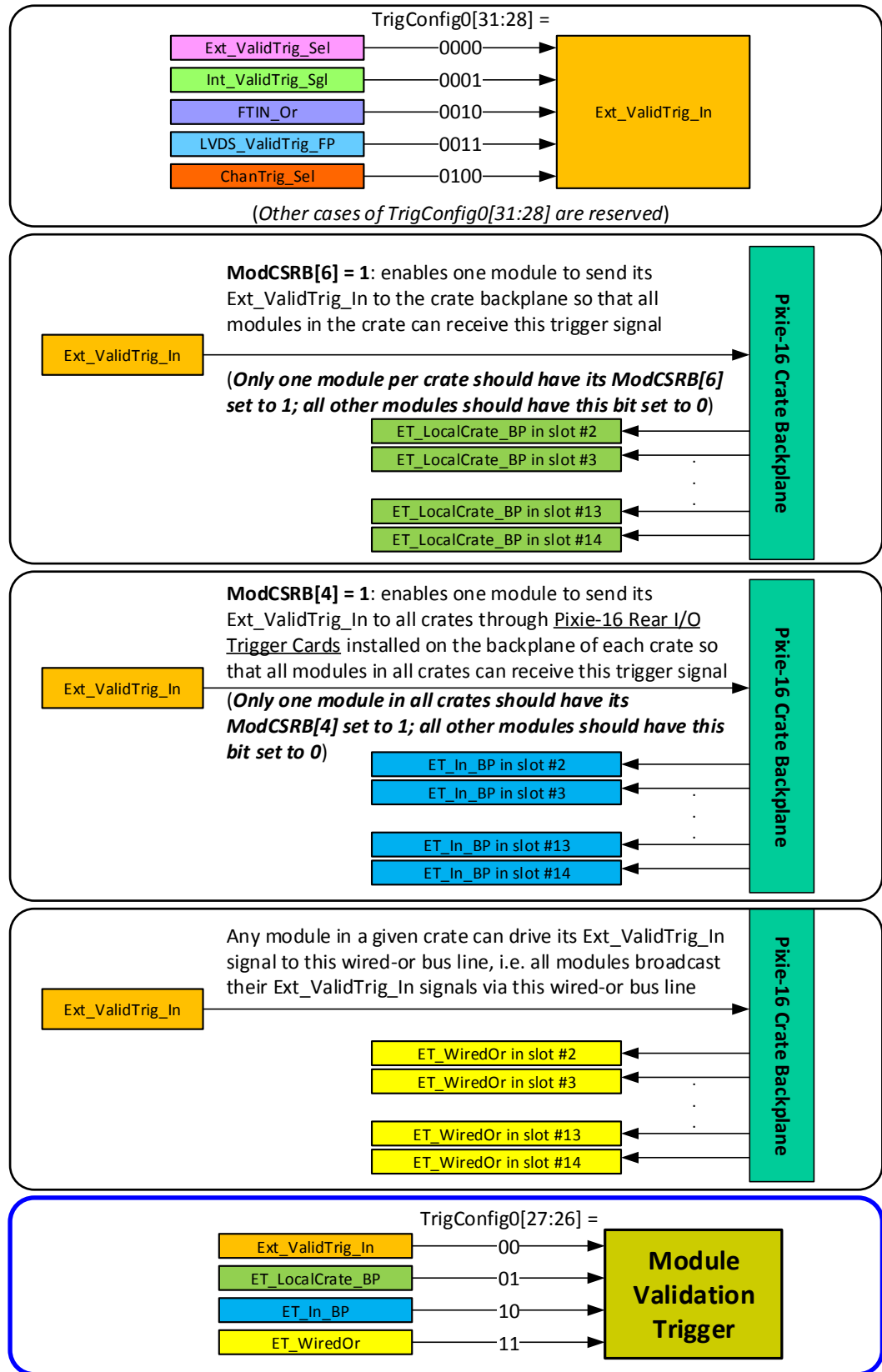

Figure 3-15: The signals and paths for generating the module validation trigger

Figure 3-5 shows that the module validation trigger is generated in the System FPGA, and then sent to the Signal Processing FPGA, where it is first latched as a single clock cycle pulse, and then stretched to a pulse whose width is set by the parameter *external trigger stretch length*. If module validation trigger requirement is enabled for the channel, i.e., bit CCSRA_GLOBTRIG of the Channel Control Register A is set to 1 (Table 3-2), only when the channel fast trigger overlaps with the module validation trigger will the event be recorded for this channel. Due to the possible delay between the channel fast trigger and module validation trigger, it might be necessary to adjust the *external delay length* (section 3.3.10) and/or *external trigger stretch length*.

3.3.11.6 Module Fast Trigger

Module fast trigger is a fast trigger signal that can be used to replace the local fast trigger for event processing and recording in the Signal Processing FPGA. It is useful for cases where when one channel triggers, other channels should record its data at the same time as well, no matter whether or not those other channels have their own fast triggers.

Figure 3-16 and Figure 3-17 list the four sources for generating the module fast trigger. The first source, *Ext_FastTrig_In*, has five sources of its own. Among those five sources, *Ext_FastTrig_Sel* comes from the front panel digital I/O ports, and *Int_FastTrig_Sgl* is selected from one of its 16 local fast triggers. The other three sources, i.e., *FTIN_Or*, *LVDS_ValidTrig_FP* and *ChanTrig_Sel*, are the same ones used for the *Ext_ValidTrig_In* signal.

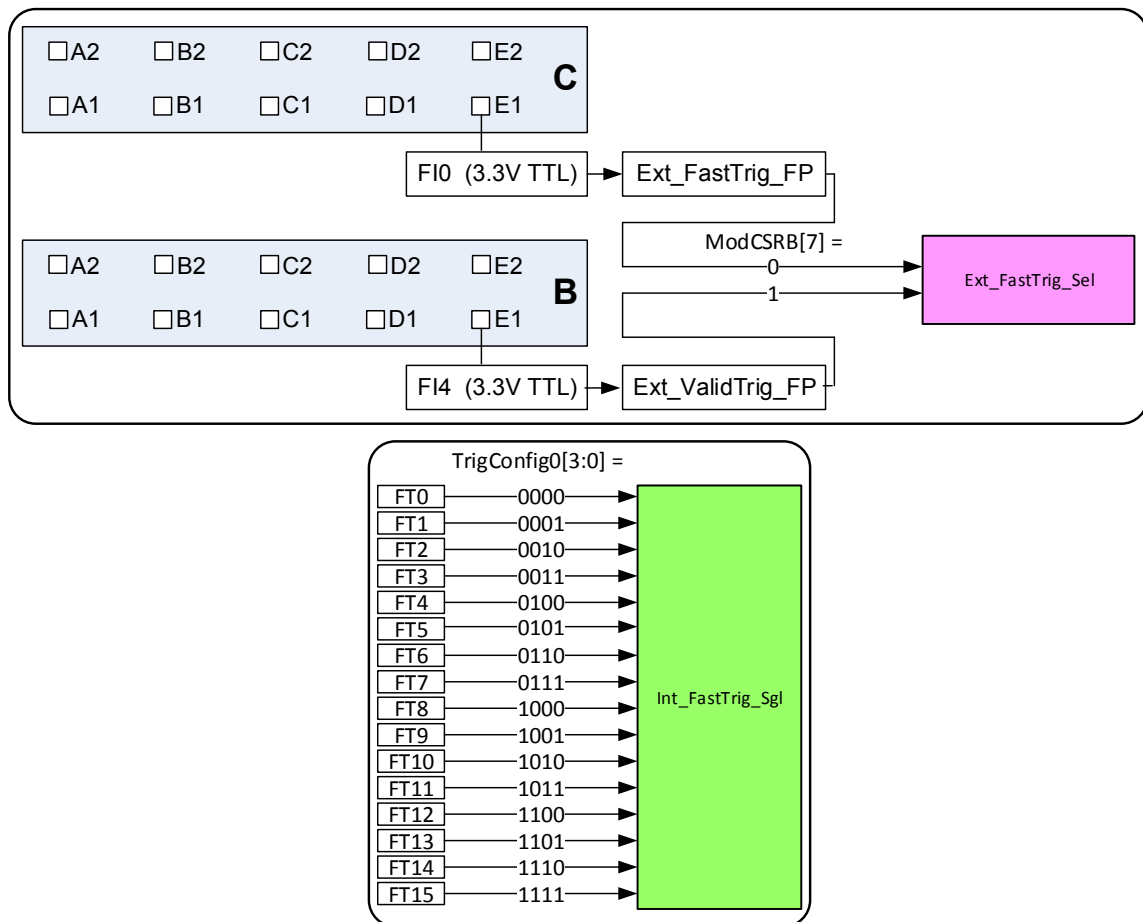

Figure 3-16: The sources for the external fast trigger

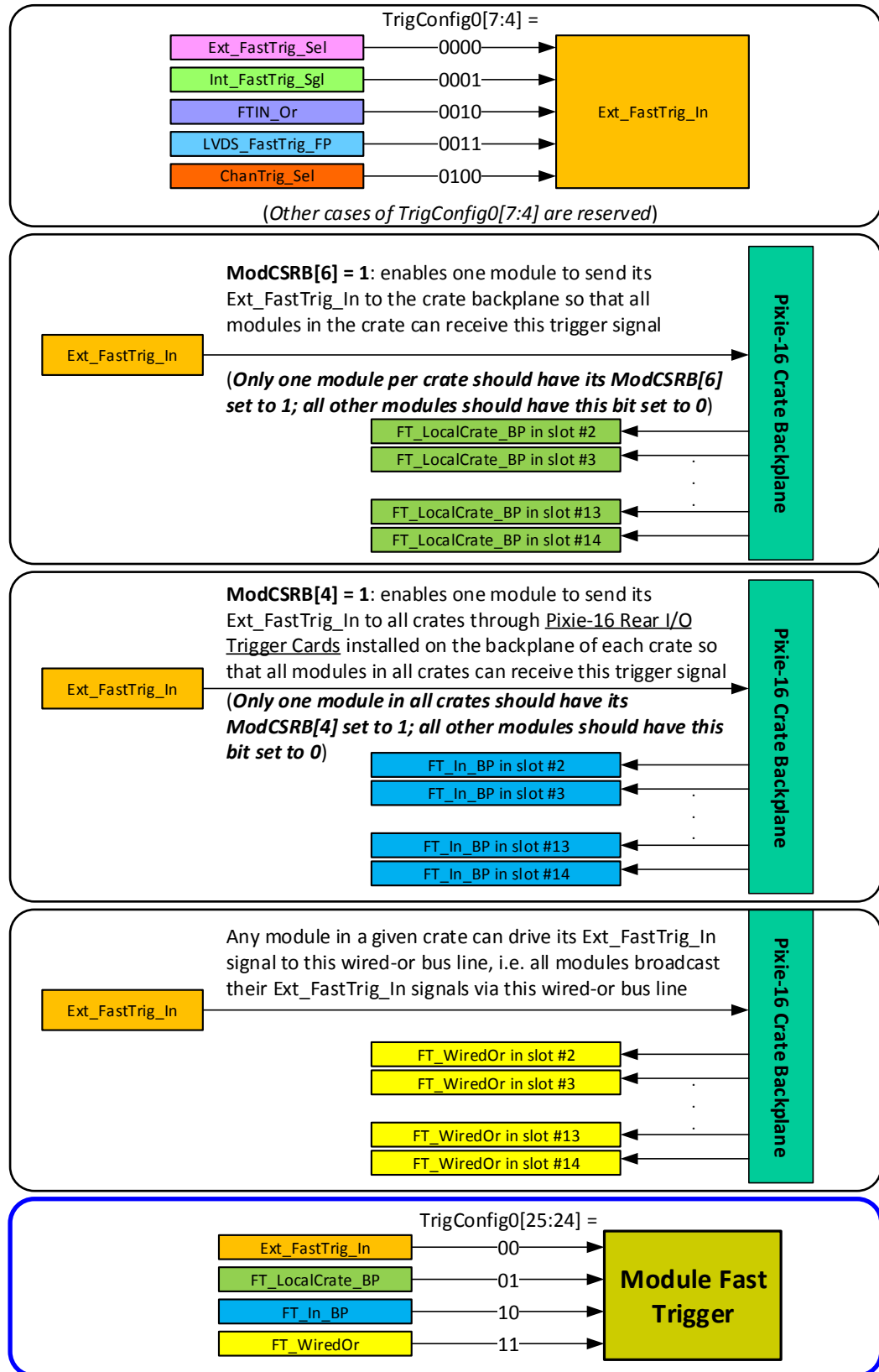

Figure 3-17: The signals and paths for generating the module fast trigger

3.3.12 QDC

Eight QDC sums, each of which can have different lengths, are computed in the Signal Processing FPGA of a Pixie-16 module for each channel and the sums are written to the list mode output data stream if the user requests so. The recording of QDC sums starts at the waveform point which is *Pre-trigger Trace Length* or *Trace Delay* earlier than the trigger point, which is either the CFD trigger or channel fast trigger depending on whether or not CFD trigger mode is enabled. The eight QDC sums are computed one by one continuously, but they are not overlapping. The recording of QDC sums ends when the eight intervals have all passed.

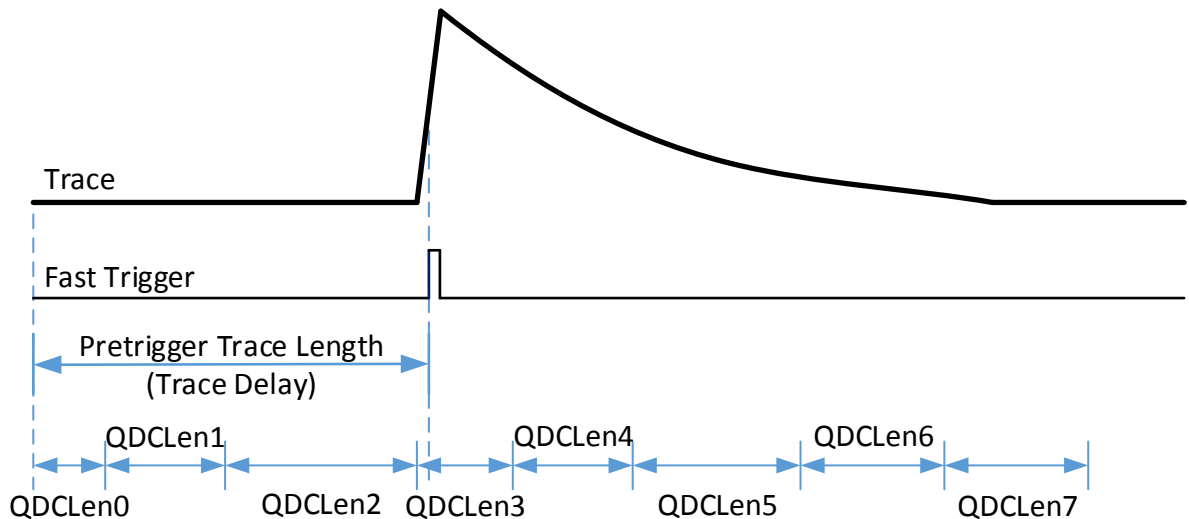

Figure 3-18: The 8 QDC sums of a triggered event.

3.4 Run

At the top of the **Run** tab is a control to specify the run type: MCA mode run (0x301) in which histograms and run statistics are acquired, or list mode run (0x100) in which list mode data, histograms and run statistics are all acquired.

For MCA runs, data acquisition continues until the specified *run time* is reached or the run is stopped manually by the user who clicks on the **[Stop]** button. In list mode runs, the on-board external FIFO memory (256k×18) will fill up as events are acquired and therefore it has to be read out continuously by the host software. The run time here only acts as a *time out* control after which the user interface aborts the run if the preset *Number of FIFO fills in Module 0* has not been reached within the preset *run time*. Each FIFO fill is equivalent to 128k 32-bit list mode data words. If Module 0 has the lowest count rate, then other modules could acquire far more list mode data than Module 0 does before the preset *Number of FIFO fills in Module 0* is reached or the run is stopped by the user. The *polling time* is important only for list mode runs – the run status should be polled as quickly as possible to ensure that once the on-board FIFO memory has sufficient data, there will be no substantial delays until the user interface notices the status of the FIFO memory and reads out the data. To acquire more than just a single FIFO memory of data, several *FIFO fills* can be requested. The number of *FIFO fills* is ignored in MCA runs.

To *synchronize* run start and run stop among all modules in the Pixie-16 system, select the checkbox “*Start/stop runs in all modules simultaneously*”. All modules will start the data acquisition at the same time; and once one module stops its acquisition, all other modules

will stop at the same time as well. This avoids the case where events are only partially acquired in different modules. To reset clock counters to zero at the beginning of the run, select the checkbox “Synchronize clocks in all modules”.

Data will be written to the *output file* specified, even if runs are aborted or manually stopped. The full file name will be “base name” plus a 4 digit run number. For MCA data, if the file already exists, the data will be overwritten. However, for list mode data, if the file already exists, the data will be appended. If the corresponding checkbox is set, the run number will be incremented automatically after each run stops.

Use the **[Start]** button to start a run, and the **[Stop]** button to manually end the run.

3.5 Results

The **Results** tab shows run statistics such as live time, input and output count rate for each channel and has 2 buttons to open the SHOW MCA SPECTRUM panel and the SHOW LIST MODE TRACES *panel*.

On the SHOW MCA SPECTRUM panel (Figure 3-19), the spectrum from each of the 16 channels is displayed after the run. The display will also be automatically updated every second during the run (in list mode run mode, the MCA display can be manually updated by clicking on **[Refresh (read from module)]** button). Previous data can be viewed by clicking on the **[Read from file]** button. In the SINGLE CHANNEL view, one channel’s MCA histogram is displayed in detail. After clicking on the **[ROI]** button and setting a region of interest, the software will automatically compute the peak area, peak position and FWHM of the peak as shown in Figure 3-20 (though these values should be verified in full featured analysis software). There are also controls that can be used to modify the behavior of the cursors and to change scaling from linear to logarithmic for the display.

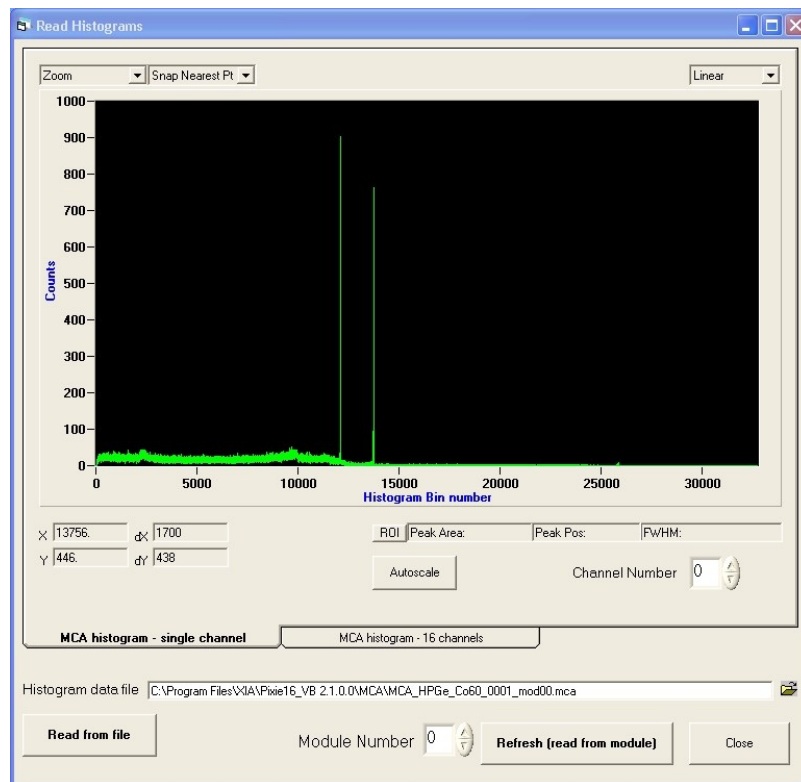

Figure 3-19: The MCA spectrum display panel.

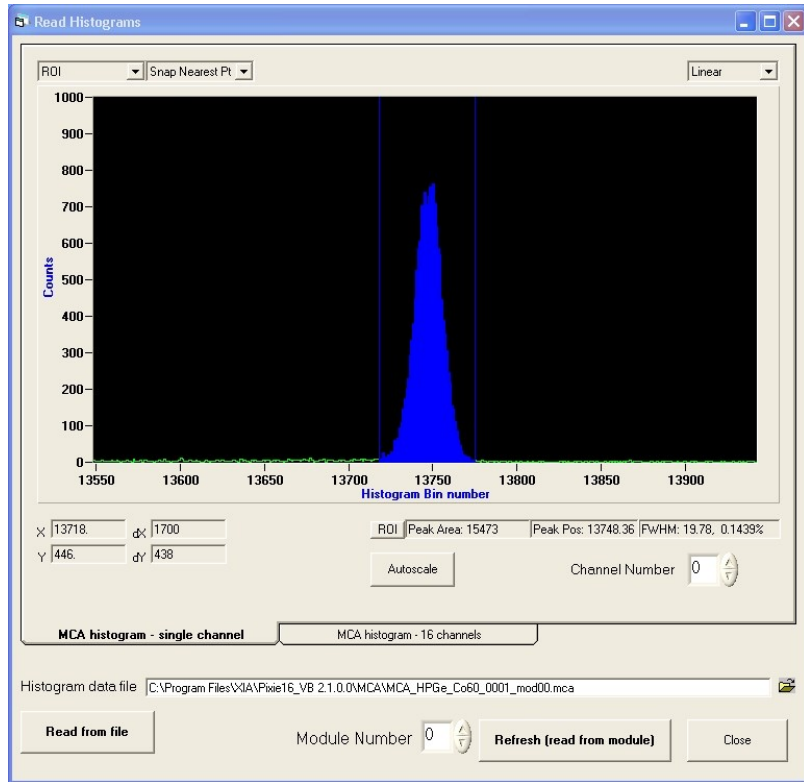

Figure 3-20: The Gaussian Fit on a MCA spectrum ROI.

On the SHOW LIST MODE TRACES panel (Figure 3-21), list mode data such as traces, timestamps, and energy values can be displayed event by event.

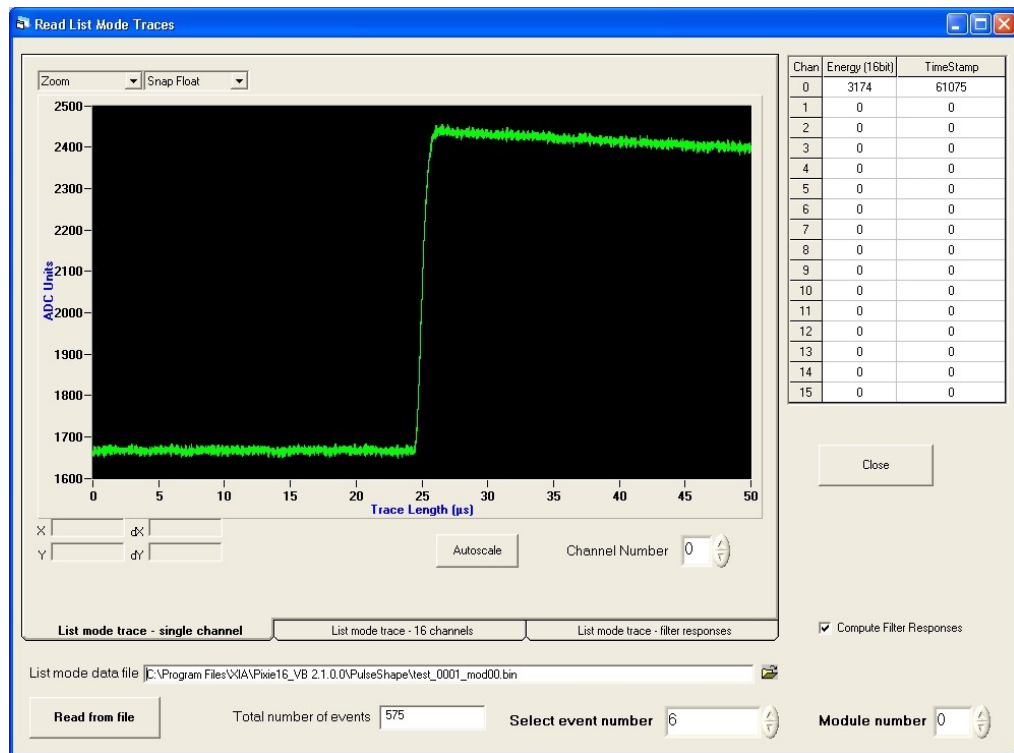

Figure 3-21: The list mode display panel.

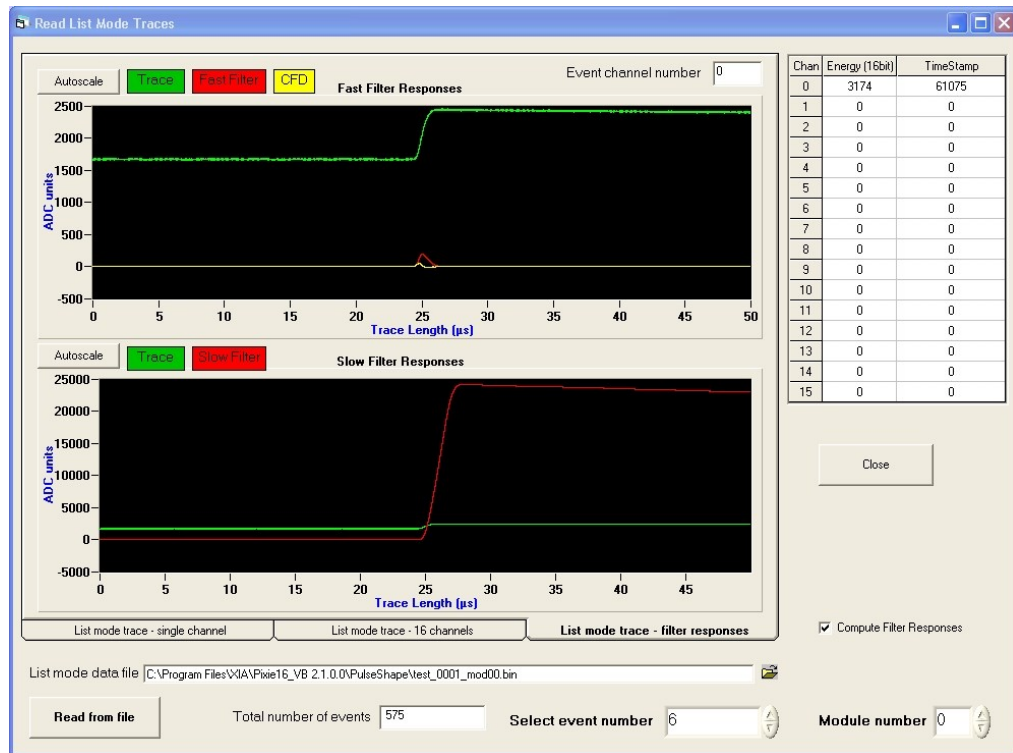
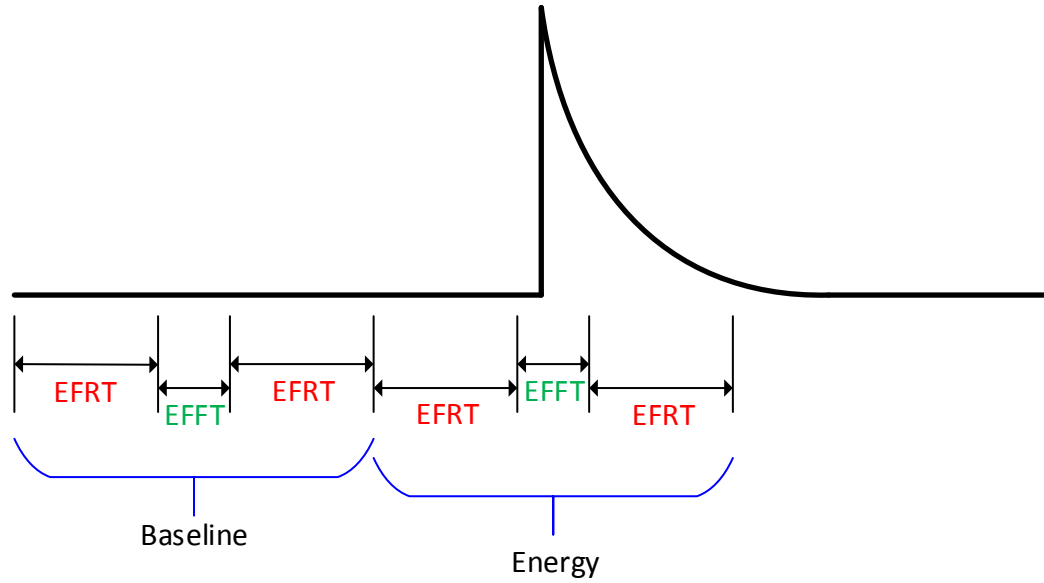

Figure 3-22: The offline computed filter responses using the recorded list mode trace.

At the end of a list mode data run, the list mode data file name will automatically get updated. Clicking on the **[Read from file]** button, the software will parse the list mode data file event by event, and report the total number of events in such a file. Each event can then be viewed one by one by using the *Select event number* control. If an event does not include trace, then only energy and timestamp will be shown for such an event. To determine to which channel an event belongs, one can tell from the **List mode trace – 16 channels** tab where 16 colored traces correspond to 16 channels, or from the channel number column where the timestamp and energy are shown.

The third tab of the SHOW LIST MODE TRACES panel is the **List mode trace – filter responses**. On this tab, fast filter responses and slow filter responses of the recorded list mode traces can be computed offline on an event by event basis if the *Compute Filter Responses* checkbox is selected. As shown in Figure 3-22, the top figure shows the fast filter and CFD responses, and the bottom figure shows the slow filter responses or energy filter responses. The computations of these filters in the offline mode use the fast filter settings, energy filter settings and CFD settings that are loaded by the Pixie-16 software at boot up. Due to the length of traces that is needed to compute the energy filter sums, the trace length should be long enough to support the offline filter response computations.

Figure 3-23 illustrates the computation of slow filter responses using the recorded list mode traces. First, the portion of trace with the length of two times energy filter rise time plus one energy filter flat top is used to compute the baseline value of the trace. Second, a second portion of trace with the length of two times energy filter rise time plus one energy filter flat top is used to compute the raw energy value. The net energy, which equals to the raw energy value subtracted by the baseline value, is then called the pulse energy. Thus, the total trace length should be at least two times the sum of two times energy filter rise time and one energy filter flat top, and the pre-trigger trace length or trace delay should be at least the sum of three times the energy filter rise time and one energy filter flat top.



$$\text{Net Energy} = \text{Energy} - \text{Baseline}$$

EFRT = Energy Filter Rise Time

EFFT = Energy Filter Flat Top

To compute energy filter response offline, the ideal settings are:

1. Total trace length > $2 * (2 * \text{EFRT} + \text{EFFT})$
2. Pre-trigger trace (Trace-delay) length > $(3 * \text{EFRT} + \text{EFFT})$

Figure 3-23: Illustration of offline computation of slow filter response.

4 Data Acquisition and Data Structures

4.1 Run Types

There are two major types of data acquisition runs: MCA runs and List mode runs. MCA runs only collect spectra and run statistics, List mode runs acquire data on an event-by-event basis, but also collect spectra and run statistics.

The output data are stored in three different memory blocks. The MCA block resides in a dedicated spectrum memory. List mode data is buffered in a FIFO that can be read out by the PC software continuously. Run statistics are kept in local memory of the DSP.

4.1.1 MCA Runs

If only energy spectra are of interest, a MCA run should be used. For each event, this type of run only calculates pulse heights (energies). The energy values are then used to increment the MCA spectrum. The run continues until the host computer stops data acquisition, either by reaching a preset run time in the host software, or by a manual stop from the user.

The only data transferred between a Pixie-16 module and host PC during a MCA run are the MCA spectra and run statistics, either through periodic update or manual update.

4.1.2 List Mode Runs

If, on the other hand, data should be collected on an event-by-event basis, including energies, time stamps, waveforms, etc., a list mode run should be used. In list mode, pulse heights are still histogrammed into MCA spectra, e.g., for monitoring purposes. The list mode data is continuously transferred from the Pixie-16 module to the host PC.

For all Pixie-16 revisions, the list mode data consists of an event header, and a block of trace data if trace recording is enabled for a given channel. The event header contains all the necessary information to identify to which channel this event belongs, as well as information about the event itself, such as timestamp, energy, and other event characteristics. A user has the flexibility to select, through software settings (i.e., the ChanCSRA parameter), the event information that should be recorded.

4.1.3 Summary of Run Types

The Run Types described above are summarized in Table 4-1.

Table 4-1 Summary of run types and data files.

Run Type	Output Data	RUNTASK	Files Created
MCA Mode	Spectra in MCA memory Run statistics in DSP memory	0x301	.mca binary spectra .set binary settings (run statistics included) .asc Spectra in ASCII format
List Mode	Energies, timestamps, waveforms, and other event information in FIFO Spectra in MCA memory Run statistics in DSP memory	0x100	.bin binary list mode data .mca binary spectra .set binary settings (run statistics included) .asc Spectra in ASCII format

4.2 Output Data Structures

4.2.1 MCA Histogram Data Structure

In Pixie-16, each channel is allocated a MCA memory block of 32K words (each word is 32-bit, and K means 1024), for a total MCA memory size of 512K words for the whole module. If spectra of less than 32K length are requested through software settings (i.e., histogram binning factor), only part of the 32K will be filled with data. For instance, if the histogram binning factor is set to 4, resulting in a 4 K words spectrum, the first 4 K of the 32 K will be filled with real MCA data whereas the remaining 28 K words will be all zeros.

Histogram data is automatically read and saved to file at the end of the run. The file has the extension .mca and contains 512K binary numbers (32 bit unsigned, low byte first). The first 32 K words of this .mca file belong to channel 0 (first channel), the second 32 K words belong to channel 1, and so on ...

4.2.2 List Mode Data Structures

4.2.2.1 Event Header

The list mode event header always starts with a 4-word (32-bit) block, which includes the event identification information, timestamp, energy and trace length, etc. Following this always-present 4-word block are the optional data blocks whose recording is selectable by the user. The placement of these data blocks in the event header always follows the order as described below. If the recording of a specific data block is not enabled by the user, all subsequent data blocks would simply shift upward by the length of the disabled data block.

In word 0, Chan# is the channel number. SlotID is the PXI slot number. CrateID is the PXI crate number. Header Length specifies the length of this event header. Event length specifies the length of this event, which could include both event header and trace. If Event Length equals to Header Length, Trace Length should be zero and no trace is recorded for this event. Finish code indicates whether this event is a piled up event (Finish Code = 1) or a single event (Finish Code = 0).

In word 1, EVTTIME_LO is the lower 32-bit of the 48-bit event timestamp recorded by the signal processing FPGA. This 48-bit event timestamp (see 4.2.3.1) is latched by either the leading edge channel fast trigger or CFD trigger.

In word 2, EVTTIME_HI is the upper 16-bit of the 48-bit event timestamp. The result of the CFD computation (if enabled) varies slightly for the different ADC rates and precisions, see below.

In word 3, Event Energy is the 16-bit energy of the event computed by the Pixie-16. The Trace Length is the length of the trace recorded for the event (in samples). If no trace is recorded, Trace Length will be 0. The trace out of range flag is an indicator showing whether or not the trace is out of the ADC range when the event is recorded. This could happen if the event pulse's amplitude is too big, causing the trace to be clipped over the upper limit of the ADC.

The 4-word fixed event header is followed by an optional 4-word block for raw energy sums and baselines (for debugging), and optional block of 8 QDC sums, and an optional block of 2 words for external time stamps.

Table 4-2 Pixie-16 list mode event header data structure.

Index	Data (32bit words)						Description
0	[31]	[30:17]	[16:12]	[11:8]	[7:4]	[3:0]	Fixed 4-word event header, word #0
	Finish Code (1 if piled up)	Event Length (32bit words)	Header Length (32bit words)	CrateID	SlotID	Chan#	
1	[31:0]						Fixed 4-word event header, word #1
	EVTTIME_LO[31:0]						
2	[31:16]			[15:0]			Fixed 4-word event header, word #2
	CFD Result [15:0]			EVTTIME_HI[15:0]			See below for variant information
3	[31]	[30:16]		[15:0]			Fixed 4-word event header, word #3
	Trace Out-of-Range Flag	Trace Length (in samples or 16bit words)		Event Energy			
4	Energy sum – trailing [31:0]						Trailing energy sum
5	Energy sum – leading [31:0]						Leading energy sum
6	Energy sum – gap [31:0]						Gap energy sum
7	Baseline [31:0]						Baseline value (32-bit IEEE 754 floating point)
8	QDCSum0 [31:0]						QDC sum #0
9	QDCSum1 [31:0]						QDC sum #1
10	QDCSum2 [31:0]						QDC sum #2
11	QDCSum3 [31:0]						QDC sum #3
12	QDCSum4 [31:0]						QDC sum #4
13	QDCSum5 [31:0]						QDC sum #5
14	QDCSum6 [31:0]						QDC sum #6
15	QDCSum7 [31:0]						QDC sum #7
16	Ext_TS_Lo [31:0]						Lower 32-bit of 48-bit external clock timestamp
17	[31:16] not used, 0's		Ext_TS_Hi [15:0]				Upper 16-bit of 48-bit external clock timestamp

4.2.2.2 Waveforms

If trace recording is enabled, trace data will immediately follow the last word of the event header. Since raw ADC data points can be 16-bit, 14-bit or 12-bit numbers depending on the ADC variant that is used, two ADC data numbers are packed into one 32-bit word to improve the storage efficiency, as shown below. Since the event header could have variable length (4 to 18 words) depending on the selection of various output data options, the header length, event length and trace length that are recorded in the first 4 words of the event header should be used to parse each event data block and navigate through the output data file. For Pixie-16 variants with 12-bit ADC's, the upper 4 bits of each 16-bit ADC data

number are filled with 0's. For Pixie-16 variants with 14-bit ADC's, the upper 2 bits of each 16-bit ADC data number are filled with 0's.

Table 4-3 Pixie-16 list mode trace data structure.

Index	Data		Description
n	Last word of event header [31:0]		Last word of event header. The event header could be 4, 6, 8, 10, 12, 14, 16 or 18 words long
n+1	ADC Data #1 [15:0]	ADC Data #0 [15:0]	Packing of ADC Data #0 and #1
n+2	ADC Data #3 [15:0]	ADC Data #2 [15:0]	Packing of ADC Data #2 and #3
...	...		

4.2.2.3 CFD results

Table 4-4 Word 2 of Event Header for different Pixie-16 variants.

Variant	Data			
100 MHz Rev. B/C/D (12bit) Rev. F (14bit)	[31]	[30:16]		[15:0]
	CFD forced trigger bit	CFD Fractional Time[14:0] × 32768		EVTTIME_HI[15:0]
250 MHz Rev. F (12, 14 or 16bit)	[31]	[30]	[29:16]	[15:0]
	CFD forced trigger bit	CFD trigger source bit	CFD Fractional Time[13:0] × 16384	EVTTIME_HI[15:0]
500 MHz Rev. F (12 or 14it)	[31:29]		[28:16]	[15:0]
	CFD trigger source bits [2:0]		CFD Fractional Time[12:0] × 8191	EVTTIME_HI[15:0]

The CFD fractional time is the CFD trigger time computed by the Pixie-16. It is multiplied by a power of two before being stored in the event header to report the fraction as an integer number. The power of 2 varies for the ADC digitization rate. The CFD fractional time will be 0 if CFD trigger is not enabled. To get the actual CFD fractional time, the CFD Fractional Time [N:0] stored in the event header should be first divided by that power of two. The CFD forced trigger bit indicates whether the CFD trigger is forced (1) or not forced (0). A forced CFD trigger is needed to avoid that the Pixie-16 channel gets stuck in an infinite loop if the CFD threshold is set too high or no zero crossing is encountered after 32 clock cycles have passed after the local fast trigger point. If the CFD forced trigger bit is 1, the CFD fractional time will be zero.

As explained in section 3.3.8.1, in 250 MHz Pixie-16 modules, the ADCs run at the full 250 MHz speed, but the FPGA logic runs at 125 MHz in the Signal Processing FPGA. That means at every 8 ns interval, two 4 ns ADC samples are processed in parallel. And as described in section 3.3.8.2, in the 500 MHz modules, the ADCs run at the full 500 MHz speed, and the ADC data coming into the FPGA are first captured by the FPGA at 500

MHz, but for all subsequent signal processing in the FPGA, the clock speed is at one fifth of that speed, i.e., 100 MHz. This also means at every 10 ns interval when running at 100 MHz, five ADC samples are processed together in parallel.

However, the CFD logic in the 250 (or 500) MHz Pixie-16 still looks for the CFD zero crossing point at every 4 (or 2 ns) ADC sample. Therefore, when using the 8 ns (or 10 ns) clock to capture the CFD zero crossing point location, there are two (or five) possibilities of the CFD zero crossing: it could either occur at the first 4 ns of the 8 ns interval (odd cycle) or at the second 4 ns of the 8 ns interval (even cycle) (or in any of the 5 samples per cycle). The Pixie-16 outputs such “within-cycle” information using the CFD trigger source bits in the event header. Offline analysis program can then know exactly when the CFD zero crossing occurred and the exact CFD fractional time can be known (see section 4.2.3)

4.2.3 List Mode Data Values

4.2.3.1 List Mode Time Stamps

In the Pixie-16, there is a 48-bit timestamp counter, which increments at a rate of either 100 MHz clock ticks (Rev. B/C/D, or 100 MHz Rev. F, or 500 MHz Rev. F), or 125 MHz clock ticks (250 MHz Rev. F).

When CFD trigger is enabled, the Pixie-16 also reports CFD fractional time, which is the result of interpolation of CFD zero crossing point and can significantly improve timing accuracy when compared to simply using the 48-bit timestamp whose precision is limited by the 10 ns or 8 ns clock ticks.

4.2.3.1.1 Rev. B/C/D (12-bit, 100 MHz), Rev. F (14-bit, 100 MHz)

For 100 MHz Pixie-16 modules, the following formula should be used to compute the true "time of arrival" for each event:

$$TS = \left(EVTTIME_LO[31:0] + EVTTIME_HI[15:0] * 2^{32} + \frac{CFD_Fractional_Time[14:0]}{32768} \right) * 10ns \quad (4-1)$$

If the "CFD forced trigger" bit is 1, then CFD_Fractional_Time[14:0] will be 0:

$$TS = \left(EVTTIME_LO[31:0] + EVTTIME_HI[15:0] * 2^{32} \right) * 10ns \quad (4-2)$$

4.2.3.1.2 Rev. F (12, 14, or 16-bit, 250 MHz)

For 250 MHz Pixie-16 modules, the “CFD trigger source” bit is recorded in bit 30 of the third word of the channel header, and the “CFD forced trigger bit” is recorded in bit 31 of the third word of the channel header.

If the “CFD trigger source” bit is 1, the CFD zero crossing point is in the odd clock cycle of the captured 250 MHz ADC waveforms. And if the “CFD trigger source” bit is 0, the CFD zero crossing point is in the even clock cycle. Please note, if CFD forced trigger bit is 1, i.e., CFD trigger is forced, the CFD trigger source bit defaults to 1, and the CFD_Fractional_Time[13:0] will be 0.

Since the 250 MHz ADC waveforms are recorded in pairs with the 125 MHz clock, the following formula should be used to compute the true “time of arrival” for each event.

If the “CFD forced trigger bit” is 0:

$$EVT = EVTTIME_LO[31:0] + EVTTIME_HI[15:0] * 2^{32} \quad (4-3)$$

$$TS = \left(EVT * 2 - CFD_trigger_source_bit + \frac{CFD_Fractional_Time[14:0]}{16384} \right) * 4ns \quad (4-4)$$

If the “CFD forced trigger bit” is 1:

$$TS = \left(EVTTIME_LO[31:0] + EVTTIME_HI[15:0] * 2^{32} \right) * 8ns \quad (4-5)$$

4.2.3.1.3 Rev. F (12 or 14-bit, 500 MHz)

In 500 MHz Pixie-16 modules, as discussed in section 3.3.8.2, the FPGA processes 5 ADC samples at a time with the 100 MHz clock, and the 48-bit timestamp is counted in 100 MHz clock ticks, i.e., 10 ns intervals. The CFD trigger also runs at 100 MHz, but the CFD zero crossing point is still reported as a fractional time between two adjacent 500 MHz ADC samples. It consists of two parts: (1) a shift within the 5 ADC samples and (2) a fractional time between two of those 5 ADC samples where the CFD zero crossing occurred. The CFD trigger source bits [2:0] are defined as zero cross point (ZCP), or the shift within the 5 ADC samples. The CFD Fractional Time[12:0] is the time between two of those 5 ADC samples where the CFD zero crossing occurred.

The following formula can be used to compute the true "time of arrival" for each event when CFD trigger is not forced, i.e., when CFD trigger source bits is not 7:

$$EVT = EVTTIME_LO[31:0] + EVTTIME_HI[15:0] * 2^{32} \quad (4-6)$$

$$TS = \left(EVT * 5 + CFD_trigger_source_bits[2:0]-1 + \frac{CFD_Fractional_Time[12:0]}{8192} \right) * 2ns \quad (4-7)$$

When CFD trigger is forced, CFD_Fractional_Time[12:0] will be 0, and the formula will just be:

$$TS = \left(EVTTIME_LO[31:0] + EVTTIME_HI[15:0] * 2^{32} \right) * 10ns \quad (4-8)$$

4.2.3.2 List Mode Energy

The energy reported in list mode data is the result of the pulse height measurement. This 16-bit number is *not* simply the difference between baseline and maximum sample of the pulse, but rather the result of the energy filter corrected for the exponential decay of the signal.

The energy is also histogrammed in MCA memory. However, since the MCA has only 32Kins, the 16-bit energy value is divided by 2 (or other user defined power of 2) before incrementing the MCA, i.e., bin (E/2) is incremented by 1 for measured energy E.

If an event is a piled up event, or if the event's trace out-of-range flag is set to 1, the event's energy will be defaulted to 0.

4.2.3.3 List Mode Trace Length

The list mode trace length is the result of trace length in time units (e.g., microseconds) divided by the ADC sampling interval. For instance, a 5 μs trace length for a channel in the 500 MHz Pixie-16 is equal to a trace length of 2500 in ADC clock ticks. The 2500 is the number reported in the event header as the trace length.

4.2.3.4 List Mode Event Length

The list mode event length is the number of 32-bit words recorded for a given event in the list mode data file. Its value depends on the event header length and the optional recording of the trace data. The event header length is the fixed 4-word header plus additional header information that is enabled by the user, e.g., raw energy filter sums, QDC sums, etc.

Since the trace is recorded in the format of two ADC data numbers packing into one 32-bit word, the event length is calculated as follows: *List mode event length = event header length + (trace length / 2)*.

4.2.3.5 List Mode Energy Sums

The list mode energy sums (leading, gap and trailing) are the 3 running sums of the digital trapezoidal filter implemented in the Pixie-16 for energy or pulse height measurement. The placement of these three energy sums is illustrated below.

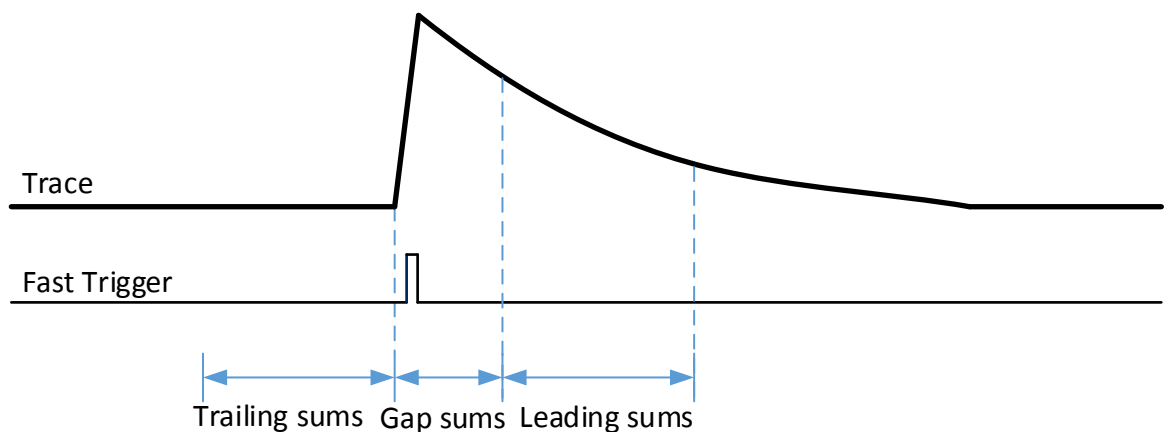

Figure 4-1: The three energy sums of a triggered event.

4.2.3.6 List Mode Baseline

The baseline is a measurement of the DC offset of the input signal with corrections to the exponential decay of the pulse. The baseline is used during the pulse height computation for a triggered event. It is not equivalent to the DC offset of the signal in value, but rather it is proportional to the DC offset. If the pulse does not decay exponentially, or it has more than one decay constants, the accuracy of the baseline measurement will be compromised.

Please note, the baseline is reported as a 32-bit IEEE 754 floating point number. A utility function is included in the Pixie-16 API library to convert between 32-bit IEEE 754 floating point number and decimal values.

4.2.3.7 List Mode QDC Sums

The Pixie-16 supports recording of 8 QDC sums for a triggered event. Each QDC sum is the summation of ADC sample values in a user defined QDC length window. Figure 3-18 illustrates the placement of the 8 QDC sums in relation to the trace recording. Please note, each QDC length can be freely adjusted through software settings (subject to allowed minimum and maximum value). That implies that the 8 QDC sums can be arranged in such ways that certain pulse shape analysis can be easily achieved.

4.2.3.8 List Mode External Clock Timestamps

The Pixie-16 is capable of accepting an external clock signal through one of its front panel connectors and then count such external clock signals before putting those external clock timestamps into the list mode data event header. Same as the Pixie-16 internal timestamps, the external clock timestamps are also 48-bit values.

4.2.3.9 Capture Timing of List Mode Data Values

The above list mode data values are captured in the firmware logic for every detected pulse. The exact timing and source of the capture signal depends on a number of trigger options. For example, waveforms can be captured based on

- *ftrig_loc*, the fast trigger from the trigger filter on this channel's input signal
- *cfdtrig*, the constant fraction logic detecting a zero crossing
- *chantrig*, this channel's coincidence test result from the System FPGA logic (the channel validation trigger)
- *ext_fasttrig*, the global fast trigger distributed over the backplane

The table below summarizes these options. All capture signals are delayed and act on ADC input streams delayed by ExternDelayLen in the DELAY FIFO (3 in Figure 3-5), except input counts are counted before the delay (marked with *).

	No CFD, local trigger	No CFD, trigger from coinc. test	No CFD, global trigger	CFD, local trigger	CFD, trigger from coinc. test	CFD, global trigger
CCSRA_ FTRIGSEL (0)	0	0	1	0	0	1
CCSRA_ CFDMODE (10)	0	0	0	1	1	1
CCSRA_ GROUPTRIGSEL (18)	0	1	ignored	0	1	ignored
Waveform	<i>ftrig_loc</i>	<i>chantrig</i>	<i>ext_fasttrig</i>	<i>cfdtrig</i>	<i>cfdtrig</i>	<i>cfdtrig</i>
Energy sums	<i>ftrig_loc</i>	<i>chantrig</i>	<i>ext_fasttrig</i>	<i>ftrig_loc</i>	<i>chantrig</i>	<i>ext_fasttrig</i>
CFD results	--	--	--	<i>cfdtrig</i>	<i>cfdtrig</i>	<i>cfdtrig</i>
QDC sums	<i>ftrig_loc</i>	<i>chantrig</i>	<i>ext_fasttrig</i>	<i>cfdtrig</i>	<i>cfdtrig</i>	<i>cfdtrig</i>
Time stamps	<i>ftrig_loc</i>	<i>chantrig</i>	<i>ext_fasttrig</i>	<i>cfdtrig</i>	<i>cfdtrig</i>	<i>cfdtrig</i>
External clock time stamps	<i>ftrig_loc</i>	<i>chantrig</i>	<i>ext_fasttrig</i>	<i>cfdtrig</i>	<i>cfdtrig</i>	<i>cfdtrig</i>
Input counts	<i>ftrig_loc</i> *	<i>ftrig_loc</i> *	<i>ftrig_loc</i> *	<i>ftrig_loc</i> *	<i>ftrig_loc</i> *	<i>ftrig_loc</i> *

4.2.4 Settings Files (Run Statistics Included)

The Pixie-16 settings file (.set) contains the values of DSP parameters that are downloaded to the onboard DSP when a Pixie-16 is booted up. In addition, at the end of each run, either MCA run or list mode run, a settings file will be automatically generated together with either the MCA spectra file (.mca and .asc) or the list mode data file (.bin) and stored in either the MCA data folder or list mode data folder. Such a settings file also contains the run statistics data for the run that is just finished.

4.2.4.1 File Format

The settings file is a binary file in the format of 32-bit unsigned integers (low byte first).

4.2.4.2 File Content

Each settings file contains settings for 24 Pixie-16 modules. And for each module, there are 1280 entries (32-bit for each entry). So the file size should be exactly 122,880 bytes. In the file, settings of module #0 are stored first, followed by module #1, #2, ... and so on.

The DSP parameters that correspond to the 1280 entries of each Pixie-16 module in the settings file are listed in the DSP parameters file, i.e., the Pixie16DSP.var file. This is a text file that can be opened with any text editor.

In the Pixie16DSP.var file, the first entry is listed at address 0x0004a000, which can be treated as index 0, where the first parameter ModNum is stored. Then at address 0x0004a001, which is index 1, the second parameter ModCSRA is stored, and so forth.

Please note between some entries in the Pixie16DSP.var file, there is a gap of 16 between two neighboring parameters, e.g., 0x0004a040 ChanCSRa and 0x0004a050 ChanCSRb. This means these parameters have 16 values, and they correspond to 16 channels of one Pixie-16 module. In other words, some parameters in the Pixie16DSP.var file has one entry only, which are Module level parameters (one per module), and some parameters have 16 entries, which are Channel level parameters (16 per module).

The first 832 parameters in the Pixie16DSP.var file are both readable and writeable. The remaining 448 parameters, i.e., starting from 0x0004a340 RealTimeA, are only readable. The run statistics data are included in those 448 parameters.

5 Hardware Description

The Pixie-16 is a 16-channel digital spectrometer designed for gamma-ray spectroscopy and waveform capturing. It incorporates four functional building blocks, which will be described below. This section concentrates on the functionality aspect. Technical specification can be found in section 1.2. Figure 5-1 shows the functional block diagram of the Pixie-16. Among them, the FIPPI0, FIPPI1, FIPPI2 and FIPPI3 FPGAs are also called the Signal Processing FPGAs in previous sections.

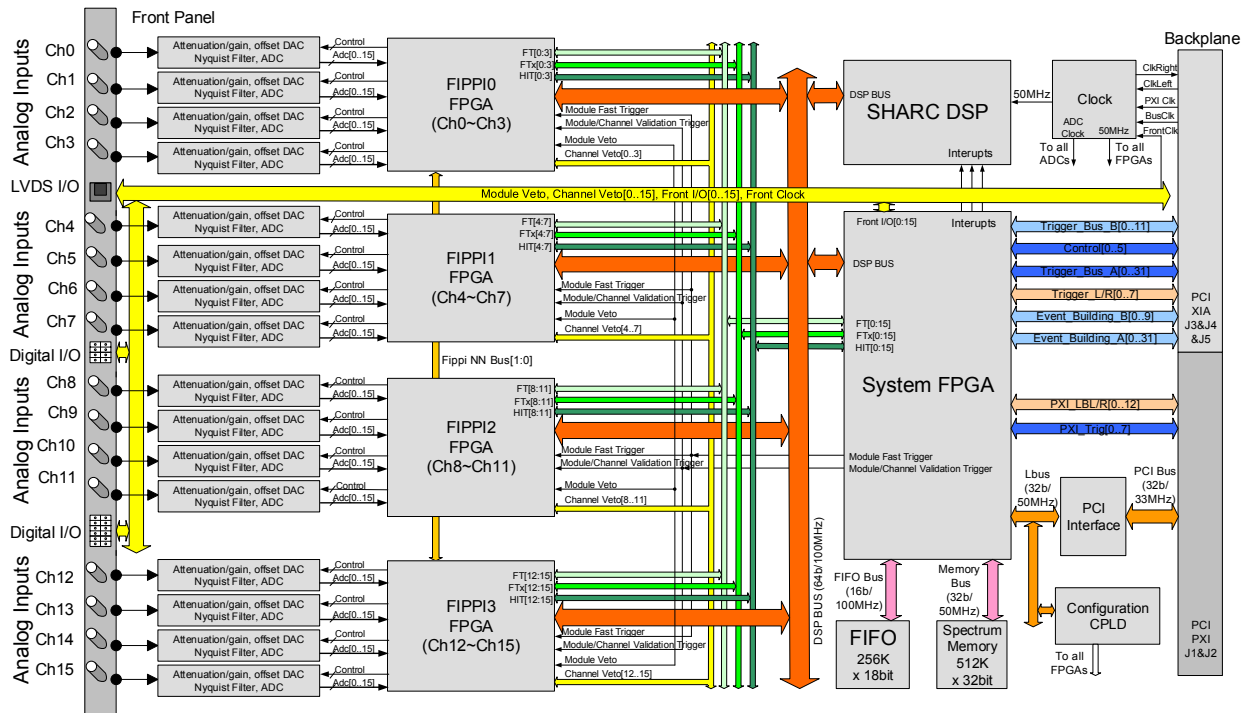

Figure 5-1: The Functional Block Diagram of the Pixie-16.

5.1 Analog Signal Conditioning

Each analog input has its own signal conditioning unit. The task of this circuitry is to adapt the incoming signals, which are DC coupled, to the input voltage range of the ADC, which spans 2V. Input signals are adjusted for offsets, and there is a computer-controlled relay which switches between two options of termination and attenuation. Fine tuning of the gain can be achieved by multiplying the calculated energy values with digital gain factors in the digital signal processor (DSP).

The ADC is not a peak sensing ADC, but acts as a waveform digitizer. In order to avoid aliasing, high frequency components from the incoming signal are removed prior to feeding it into the ADC. The anti-aliasing filter, cuts off sharply at the Nyquist frequency, namely half the ADC sampling frequency.

Though the Pixie-16 can work with many different signal forms, best performance is to be expected when sending the output from a charge integrating preamplifier or photodetectors (e.g., photomultiplier tubes) directly to the Pixie-16 without any further shaping.

5.2 Pulse Processing

Real time pulse processing is implemented in a field programmable gate array (FPGA) which also incorporates a first level FIFO memory for each channel. The data stream from the ADCs is sent to these units at the full ADC sampling rate. While modern FPGAs can capture high speed data streams, internal processing is limited by the complexity of the logic. Therefore, the FPGA on the Pixie-16 processes the data stream at either 100 or 125 MHz. For 250 MHz variants each channel's 16 (or 14) bit data stream is “de-serialized” into a 32 (or 28) bit data stream at 125 MHz. For 500 MHz variants each channel's 14 (or 12) bit data stream is “de-serialized” into a 70 (or 60) bit data stream at 100 MHz. Using a pipelined architecture, the signals are processed at this high rate, without the help of the on-board DSP.

The processing applies digital filtering to perform essentially the same action as a shaping amplifier. The important difference is in the type of filter used. In a digital application it is easy to implement finite impulse response filters, and trapezoidal filters are used in the Pixie-16. The flat top will typically cover the rise time of the incoming signal and makes the pulse height measurement less sensitive to variations of the signal shape.

The first two processing elements in the FPGA are thus a fast filter for triggering and a slow filter for pulse height (energy) measurements. For a detailed description, see section 6. These filters run continuously. Triggers are issued at each detected rising edge, and are used for latching timestamps and the other processes. The energy filter sums are latched the appropriate time after each trigger.

A third processing element is a pileup inspector. This logic ensures that if a second pulse is detected too soon after the first, so that it would corrupt the first pulse height measurement, both pulses are flagged as piled up. The pileup inspector is, however, not very effective in detecting pulse pileup on the rising edge of the first pulse, i.e., in general pulses must be separated by their rise time to be effectively recognized as different pulses. Therefore, for high count rate applications, the pulse rise times should be as short as possible, to minimize the occurrence of pileup peaks in the resulting spectra.

The fourth processing component is the FIFO memory, which is organized in two blocks. A smaller delay FIFO (1K samples) buffers ADC data to position captured waveforms appropriately for the user defined pre-trigger delay. A larger storage FIFO (8K or 4K samples) captures waveforms of the user defined trace length.

Events data are buffered in the FPGA until they are read out by the DSP. For each event, a complete set of timestamps, energy filter sums, pileup inspection flags, and waveforms are stored. User defined acceptance settings specify if an event is considered valid (e.g., only accept events without pileup).

The last processing element are a number of counters that maintain the run statistics such as counting time, number of triggers, etc.

5.3 Digital Signal Processor (DSP) and Event Building

The pulse processing described above runs independently in every channel of the Pixie-16 module. On a module-wide level, additional logic is implemented in the System FPGA to distribute triggers and apply event validation or veto tests such as multiplicity triggers or

coincidence tests. See section 3.3.11 for details. The result of the event validation or veto tests is fed back to every processing channel.

The DSP manages the flow of channel data into the External FIFO where it is waiting for PCI readout by the host PC. Whenever a channel has an event in its buffer, the DSP will read the raw data from the FPGA and based on the event status flags determine if the event is to be recorded. If the event is acceptable, the DSP computes the pulse height in a few floating point operations, and includes it in the event header data sent to the External FIFO. The captured waveform data is normally not touched by the DSP as the DSP only enables a direct FPGA-to-External FIFO transfer through the DSP Bus.

The DSP also controls the overall operation of the Pixie-16. The host computer communicates with the DSP via the PCI interface. The host sets variables in the DSP memory and if necessary calls DSP functions to apply them to the FPGA. Through this mechanism all gain and offset DACs are set and the filter settings are applied to the FPGA. The FPGA then processes the data without support from the DSP, once it has received the filter settings.

In this scheme, the greatest processing power is located in the FPGA, processing the incoming waveforms from the ADCs in real time and producing, for each valid event, a small set of distilled data from which pulse heights and arrival times can be reconstructed. The computational load for the DSP is much reduced, as it has to react only on an event-by-event basis and has to work with only a small set of numbers for each event.

5.4 PCI and Trigger Interface

The PCI interface through which the host communicates with the Pixie-16 is implemented in a PCI slave IC (PCI 9054 PCI I/O Accelerator from PLX Technology, now part of Broadcom, Inc.) together with an FPGA. The configuration of this PCI IC is stored in a PROM, which is placed in the only DIP-8 IC-socket on the Pixie-16 board. The interface conforms to the commercial PCI standard. It moves 32-bit data words at a time.

The interface does not issue interrupt requests to the host computer. Instead, for example to determine when data is ready for readout, the host has to poll status registers in the System FPGA.

The System FPGA links the PCI slave with the DSP and the on-board memory, both the MCA memory and the list mode External FIFO memory. The host can read out the memory without interrupting the operation of the DSP. This allows updates of the MCA spectrum while a run is in progress and readout of list mode data from the External FIFO while the FPGA internal FIFO is being filled with events data.

The System FPGA also acts as an interface between the DSP, Signal Processing FPGAs and the backplane. It also has general purpose I/O connections available on the front panel. It can be configured to distribute trigger and hit pattern information from the Signal Processing FPGAs, and over the backplane to other Pixie-16 modules. In this way, coincidence or multiplicity decisions can be made to accept or not accept an event.

6 Theory of Operation

6.1 Digital Filters for Radiation Detectors

Energy dispersive detectors, which include such solid state detectors as Si(Li), HPGe, HgI₂, CdTe and CZT detectors, are generally operated with charge sensitive preamplifiers as shown in Figure 6-1 (a). Here the detector D is biased by voltage source V and connected to the input of preamplifier A which has feedback capacitor C_f and feedback resistor R_f.

The output of the preamplifier following the absorption of an γ -ray of energy E_x in detector D is shown in Figure 6-1 (b) as a step of amplitude V_x (on a longer time scale, the step will decay exponentially back to the baseline, see section 6.3). When the γ -ray is absorbed in the detector material it releases an electric charge Q_x = E_x/ε, where ε is a material constant. Q_x is integrated onto C_f, to produce the voltage V_x = Q_x/C_f = E_x/(εC_f). Measuring the energy E_x of the γ -ray therefore requires a measurement of the voltage step V_x in the presence of the amplifier noise σ, as indicated in Figure 6-1 (b). Scintillator detectors read out with a photomultiplier tube generate pulses in a different mechanism, but for the most part they can still be described as fast rise followed by exponential decay, so the processing described below equally applies.

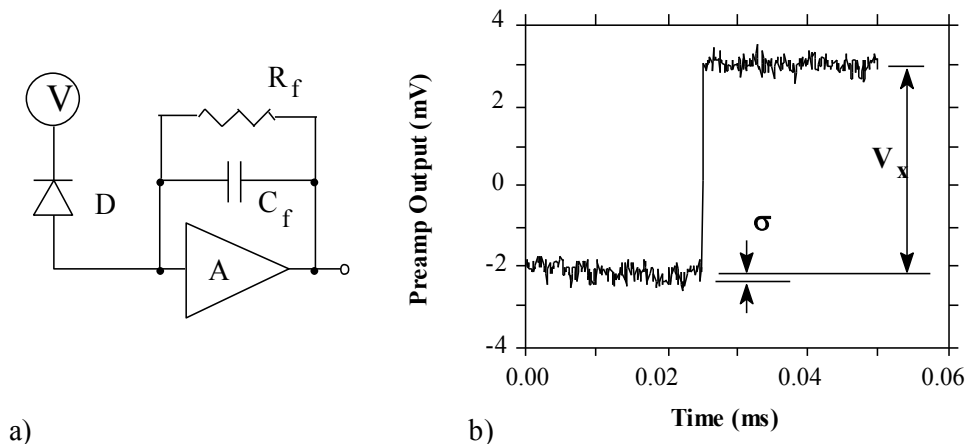

Figure 6-1: (a) Charge sensitive preamplifier with RC feedback; (b) Output on absorption of a γ -ray.

Reducing noise in an electrical measurement is accomplished by filtering. Traditional analog filters use combinations of a differentiation stage and multiple integration stages to convert the preamp output steps, such as shown in Figure 6-1 (b), into either triangular or semi-Gaussian pulses whose amplitudes (with respect to their baselines) are then proportional to V_x and thus to the γ -ray's energy.

Digital filtering proceeds from a slightly different perspective. Here the signal has been digitized and is no longer continuous. Instead it is a string of discrete values as shown in Figure 6-2. Figure 6-2 is actually just a subset of Figure 6-1 (b), in which the signal was digitized by a Tektronix 544 TDS digital oscilloscope at 10 MSPS (mega samples per second). Given this data set, and some kind of arithmetic processor, the obvious approach to determining V_x is to take some sort of average over the points before the step and subtract

it from the value of the average over the points after the step. That is, as shown in Figure 6-2, averages are computed over the two regions marked “Length” (the “Gap” region is omitted because the signal is changing rapidly here), and their difference taken as a measure of V_x . Thus the value V_x may be found from the following equation:

$$V_{x,k} = - \sum_{i(\text{before})} W_i V_i + \sum_{i(\text{after})} W_i V_i \quad (6-1)$$

Where the values of the weighting constants W_i determine the type of average being computed. The sums of the values of the two sets of weights must be individually normalized.

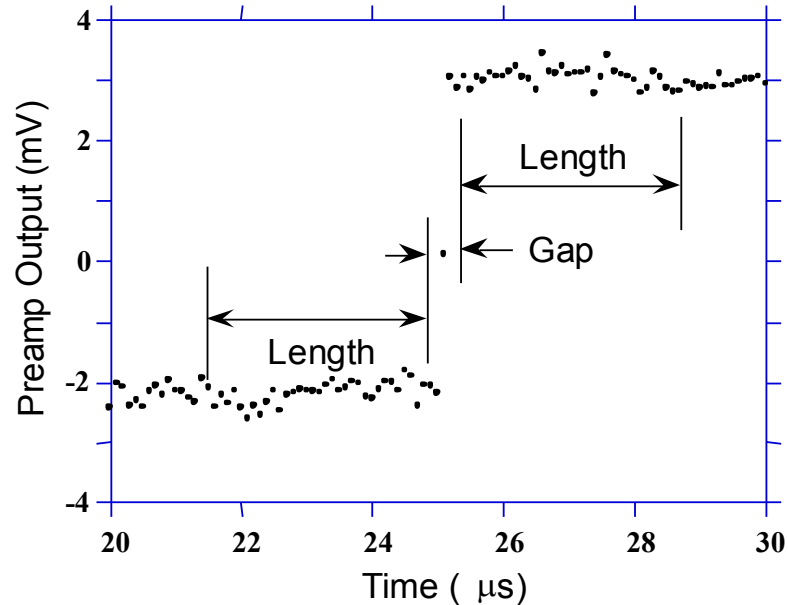

Figure 6-2: Digitized version of the data of Figure 6-1 (b) in the step region.

The primary differences between different digital signal processors lie in two areas: what set of weights W_i is used and how the regions are selected for the computation of Equation 6-1. Thus, for example, when larger weighting values are used for the region close to the step while smaller values are used for the data away from the step, Equation 6-1 produces “cusp-like” filters. When the weighting values are constant, one obtains triangular (if the gap is zero) or trapezoidal filters. The concept behind cusp-like filters is that, since the points nearest the step carry the most information about its height, they should be most strongly weighted in the averaging process. How one chooses the filter lengths results in time variant (the lengths vary from pulse to pulse) or time invariant (the lengths are the same for all pulses) filters. Traditional analog filters are time invariant. The concept behind time variant filters is that, since the γ -rays arrive randomly and the lengths between them vary accordingly, one can make maximum use of the available information by setting the length to the interpulse spacing.

In principle, the very best filtering is accomplished by using cusp-like weights and time variant filter length selection. There are serious costs associated with this approach however, both in terms of computational power required to evaluate the sums in real time and in the complexity of the electronics required to generate (usually from stored coefficients) normalized W_i sets on a pulse by pulse basis.

The Pixie-16 takes a different approach because it was optimized for high speed operation. It implements a fixed length filter with all W_i values equal to unity and in fact computes this sum afresh for each new signal value k . Thus the equation implemented is:

$$LV_{x,k} = - \sum_{i=k-2L-G+1}^{k-L-G} V_i + \sum_{i=k-L+1}^k V_i \quad (6-2)$$

Where the filter length is L and the gap is G . The factor L multiplying $V_{x,k}$ arises because the sum of the weights here is not normalized. Accommodating this factor is trivial.

While this relationship is very simple, it is still very effective. In the first place, this is the digital equivalent of triangular (or trapezoidal if $G \neq 0$) filtering which is the analog industry's standard for high rate processing. In the second place, one can show theoretically that if the noise in the signal is white (i.e., Gaussian distributed) above and below the step, which is typically the case for the short shaping times used for high signal rate processing, then the average in Equation 6-2 actually gives the best estimate of V_x in the least squares sense. This, of course, is why triangular filtering has been preferred at high rates. Triangular filtering with time variant filter lengths can, in principle, achieve both somewhat superior resolution and higher throughputs but comes at the cost of a significantly more complex circuit and a rate dependent resolution, which is unacceptable for many types of precise analysis. In practice, XIA's design has been found to duplicate the energy resolution of the best analog shapers while approximately doubling their throughput, providing experimental confirmation of the validity of the approach.

6.2 Trapezoidal Filtering in a Pixie-16 Module

From this point onward, only trapezoidal filtering will be considered as it is implemented in a Pixie-16 module according to Equation 6-2. The result of applying such a filter with Length $L=1\mu\text{s}$ and Gap $G=0.4\mu\text{s}$ to a γ -ray event is shown in Figure 6-3. The filter output is clearly trapezoidal in shape and has a rise time equal to L , a flattop equal to G , and a symmetrical fall time equal to L . The basewidth, which is a first-order measure of the filter's noise reduction properties, is thus $2L+G$.

This raises several important points in comparing the noise performance of the Pixie-16 module to analog filtering amplifiers. First, semi-Gaussian filters are usually specified by a *shaping time*. Their rise time is typically twice this and their pulses are not symmetric so that the basewidth is about 5.6 times the shaping time or 2.8 times their rise time. Thus a semi-Gaussian filter typically has a slightly better energy resolution than a triangular filter of the same rise time because it has a longer filtering time. This is typically accommodated in amplifiers offering both triangular and semi-Gaussian filtering by stretching the triangular rise time a bit, so that the *true* triangular rise time is typically 1.2 times the selected semi-Gaussian rise time. This also leads to an apparent advantage for the analog system when its energy resolution is compared to a digital system with the same nominal rise time.

One important characteristic of a digitally shaped trapezoidal pulse is its extremely sharp termination on completion of the basewidth $2L+G$. This may be compared to analog filtered pulses whose tails may persist up to 40% of the rise time, a phenomenon due to the finite bandwidth of the analog filter. As can be seen below, this sharp termination gives the digital filter a definite rate advantage in pileup free throughput.

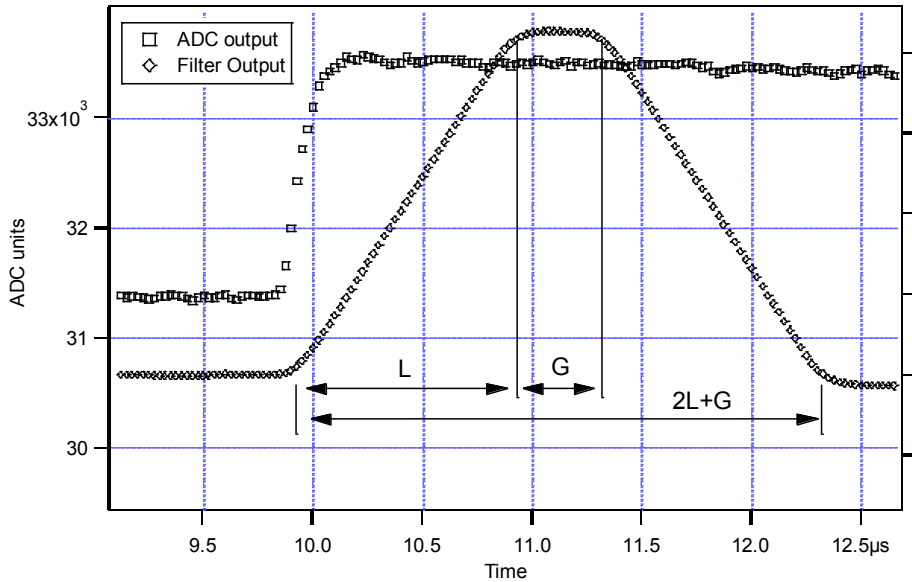

Figure 6-3: Trapezoidal filtering of a preamplifier step with $L=1\mu\text{s}$ and $G=0.4\mu\text{s}$.

6.3 Baselines and Preamplifier Decay Times

Figure 6-4 shows an event over a longer time interval and how the filter treats the preamplifier noise in regions when no γ -ray pulses are present. As may be seen the effect of the filter is both to reduce the amplitude of the fluctuations and reduce their high frequency content. This region is called the *baseline* because it establishes the reference level from which the γ -ray peak amplitude V_x is to be measured. The fluctuations in the baseline have a standard deviation σ_e which is referred to as the *electronic noise* of the system, a number which depends on the rise time of the filter used. Riding on top of this noise, the γ -ray peaks contribute an additional noise term, the *Fano noise*, which arises from statistical fluctuations in the amount of charge Q_x produced when the γ -ray is absorbed in the detector. This Fano noise σ_f adds in quadrature with the electronic noise, so that the total noise σ_t in measuring V_x is found from

$$\sigma_t = \sqrt{\sigma_f^2 + \sigma_e^2} \quad (6-3)$$

The Fano noise is only a property of the detector material. The electronic noise, on the other hand, may have contributions from both the preamplifier and the amplifier. When the preamplifier and amplifier are both well designed and well matched, however, the amplifier's noise contribution should be essentially negligible. Achieving this in the mixed analog-digital environment of a digital pulse processor is a non-trivial task, however.

With a RC-type preamplifier, the slope of the preamplifier is rarely zero. Every step decays exponentially back to the DC level of the preamplifier. During such a decay, the baselines are obviously not zero. This can be seen in Figure 6-4, where the filter output during the exponential decay after the pulse is below the initial level. Note also that the flat top region is sloped downwards.

Using the decay constant τ , the baselines can be mapped back to the DC level. This allows precise determination of γ -ray energies, even if the pulse sits on the falling slope of a

previous pulse. The value of τ , being a characteristic of the preamplifier, has to be determined by the user and host software and downloaded to the module.

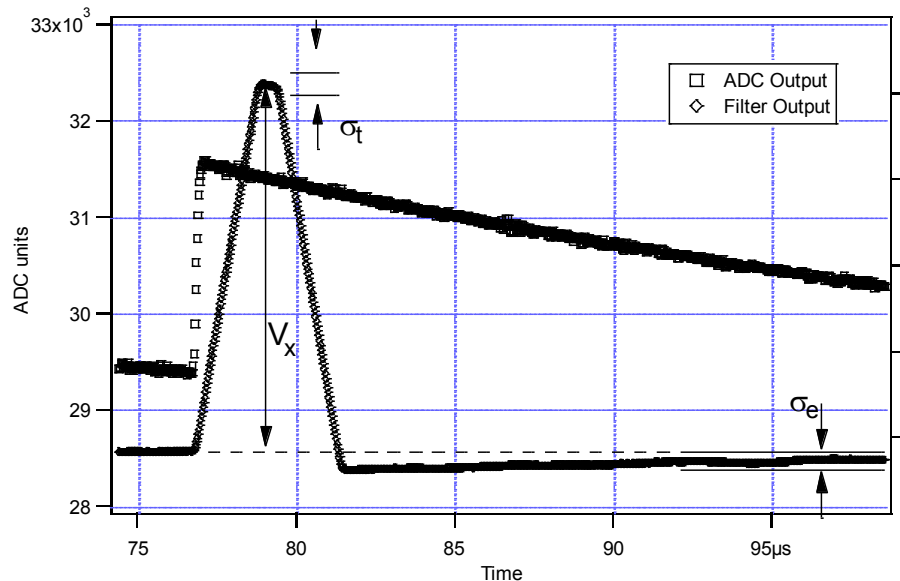

Figure 6-4: A γ -ray event displayed over a longer time period to show baseline noise and the effect of preamplifier decay time.

6.4 Thresholds and Pileup Inspection

As noted above, the goal is to capture a value of V_x for each γ -ray detected and use these values to construct a spectrum. This process is also significantly different between digital and analog systems. In the analog system the peak value must be “captured” into an analog storage device, usually a capacitor, and “held” until it is digitized. Then the digital value is used to update a memory location to build the desired spectrum. During this analog to digital conversion process the system is dead to other events, which can severely reduce system throughput. Even single channel analyzer systems introduce significant deadtime at this stage since they must wait some period (typically a few microseconds) to determine whether or not the window condition is satisfied.

Digital systems are much more efficient in this regard, since the values output by the filter are already digital values. All that is required is to take the filter sums, reconstruct the energy V_x , and add it to the spectrum. In the Pixie-16, the filter sums are continuously updated in the FPGA (see section 5.2), and are captured into event buffers. Reconstructing the energy and incrementing the spectrum is done by the DSP, so that the FPGA is ready to take new data immediately (unless the buffers are full). This is a significant source of the enhanced throughput found in digital systems.

The peak detection and sampling in a Pixie-16 module is handled as indicated in Figure 6-5. Two trapezoidal filters are implemented, a *fast filter* and a *slow filter*. The fast filter is used to detect the arrival of γ -rays, the slow filter is used for the measurement of V_x , with reduced noise at longer filter rise times. The fast filter has a filter length $L_f = 0.1\mu\text{s}$ and a gap $G_f = 0.1\mu\text{s}$. The slow filter has $L_s = 1.2\mu\text{s}$ and $G_s = 0.35\mu\text{s}$.

The arrival of the γ -ray step (in the preamplifier output) is detected by digitally comparing the fast filter output to THRESHOLD, a digital constant set by the user. Crossing the threshold starts a delay line to wait PEAKSAMP clock cycles to arrive at the appropriate

time to sample the value of the slow filter. Because the digital filtering processes are deterministic, PEAKSAMP depends only on the values of the fast and slow filter constants. The slow filter value captured following PEAKSAMP is then the slow digital filter's estimate of V_x . Using a delay line allows to stage sampling of multiple pulses even within a PEAKSAMP interval (though the filter values themselves are then not correct representations of a single pulse's height).

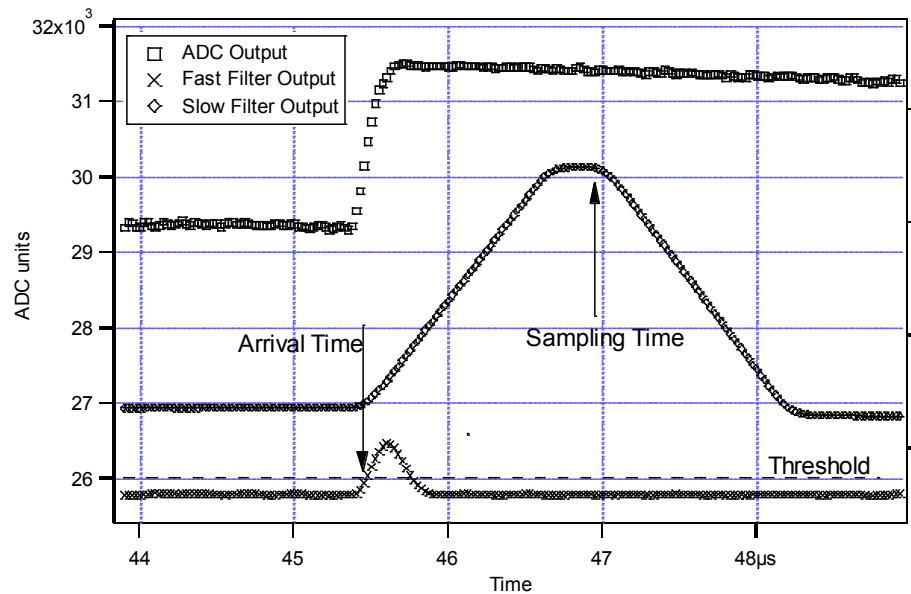

Figure 6-5: Peak detection and sampling in a Pixie-16 module.

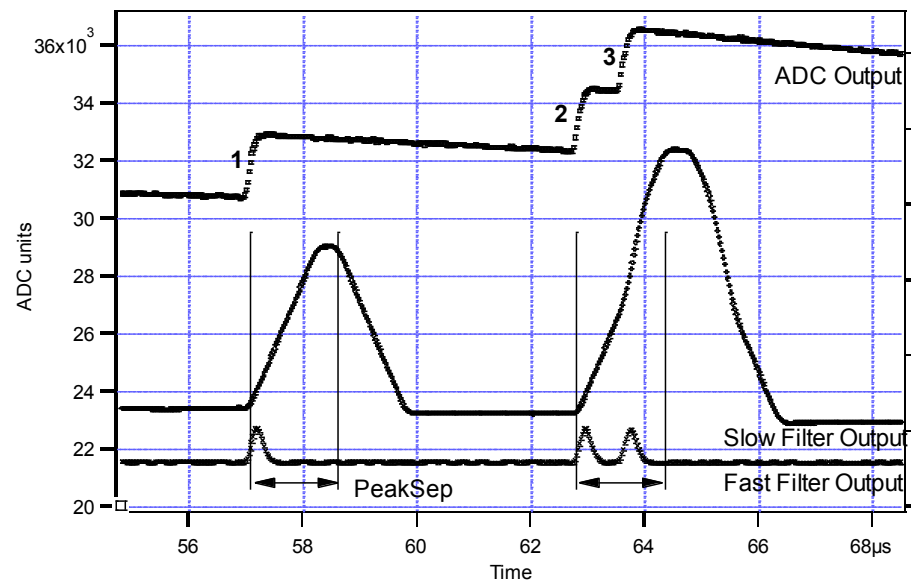

Figure 6-6: A sequence of 3 γ -ray pulses separated by various intervals to show the origin of pileup and demonstrate how it is detected by the Pixie module.

The value V_x captured will only be a valid measure of the associated γ -ray's energy provided that the filtered pulse is sufficiently well separated in time from its preceding and succeeding neighbor pulses so that their peak amplitudes are not distorted by the action of the trapezoidal filter. That is, if the pulse is not *piled up*. The relevant issues may be

understood by reference to Figure 6-6, which shows 3 γ -rays arriving separated by various intervals. The fast filter has a filter length $L_f = 0.1\mu\text{s}$ and a gap $G_f = 0.1\mu\text{s}$. The slow filter has $L_s = 1.2\mu\text{s}$ and $G_s = 0.35\mu\text{s}$.

Because the trapezoidal filter is a linear filter, its output for a series of pulses is the linear sum of its outputs for the individual members in the series. Pileup occurs when the rising edge of one pulse lies under the peak (specifically the sampling point) of its neighbor. Thus, in Figure 6-6, peaks 1 and 2 are sufficiently well separated so that the leading edge of peak 2 falls after the peak of pulse 1. Because the trapezoidal filter function is symmetrical, this also means that pulse 1's trailing edge also does not fall under the peak of pulse 2. For this to be true, the two pulses must be separated by at least an interval of $L + G$. Peaks 2 and 3, which are separated by less than $1.0\mu\text{s}$, are thus seen to pileup in the present example with a $1.2\mu\text{s}$ rise time.

This leads to an important point: whether pulses suffer slow pileup depends critically on the rise time of the filter being used. The amount of pileup which occurs at a given average signal rate will increase with longer rise times.

Because the fast filter rise time is only $0.1\mu\text{s}$, these γ -ray pulses do not pileup in the fast filter channel. The Pixie-16 module can therefore test for slow channel pileup by measuring the fast filter for the interval PEAKSEP after a pulse arrival time. If no second pulse occurs in this interval, then there is no trailing edge pileup and the pulse is validated for acquisition. PEAKSEP is usually set to a value close to $L + G + 1$. Pulse 1 passes this test, as shown in Figure 6-6. Pulse 2, however, fails the PEAKSEP test because pulse 3 follows less than $1.0\mu\text{s}$. Notice, by the symmetry of the trapezoidal filter, if pulse 2 is rejected because of pulse 3, then pulse 3 is similarly rejected because of pulse 2.

6.5 Filter Range

To accommodate a wide range of energy filter rise times from tens of nanoseconds to tens of microseconds, the filters are implemented in the FPGA with different clock decimations (filter ranges). The ADC sampling rate is either 2ns, 4ns, or 10ns depending on the ADC variant that is used, but in higher clock decimations, several ADC samples are averaged before entering the energy filtering logic. In filter range 1, 2^1 samples are averaged, 2^2 samples in filter range 2, and so on. Since the sum of rise time and flat top is limited to 127 decimated clock cycles, filter time granularity and filter time are limited to the values listed in Table 6-1 and Table 6-2.

Table 6-1 Filter clock decimations and filter time granularity for 100 MHz or 500 MHz Pixie-16 Modules

Filter range	Filter granularity	max. $T_{\text{rise}} + T_{\text{flat}}$	min. T_{rise}	min. T_{flat}
1	$0.02\mu\text{s}$	$2.54\mu\text{s}$	$0.04\mu\text{s}$	$0.06\mu\text{s}$
2	$0.04\mu\text{s}$	$5.08\mu\text{s}$	$0.08\mu\text{s}$	$0.12\mu\text{s}$
3	$0.08\mu\text{s}$	$10.16\mu\text{s}$	$0.16\mu\text{s}$	$0.24\mu\text{s}$
4	$0.16\mu\text{s}$	$20.32\mu\text{s}$	$0.32\mu\text{s}$	$0.48\mu\text{s}$
5	$0.32\mu\text{s}$	$40.64\mu\text{s}$	$0.64\mu\text{s}$	$0.96\mu\text{s}$
6	$0.64\mu\text{s}$	$81.28\mu\text{s}$	$1.28\mu\text{s}$	$1.92\mu\text{s}$

Table 6-2 Filter clock decimations and filter time granularity for 250 MHz Pixie-16 Modules

Filter range	Filter granularity	max. $T_{rise}+T_{flat}$	min. T_{rise}	min. T_{flat}
1	0.016 μ s	2.032 μ s	0.032 μ s	0.048 μ s
2	0.032 μ s	4.064 μ s	0.064 μ s	0.096 μ s
3	0.064 μ s	8.128 μ s	0.128 μ s	0.192 μ s
4	0.128 μ s	16.256 μ s	0.256 μ s	0.384 μ s
5	0.256 μ s	32.512 μ s	0.512 μ s	0.768 μ s
6	0.512 μ s	65.024 μ s	1.024 μ s	1.536 μ s

6.6 Run Statistics

6.6.1 Time and trigger counters

A number of counters measuring the counting time and number of detected triggers have been implemented in both the FPGA and DSP of a Pixie-16 module, and their results are stored in the following DSP output variables:

RUN TIME

The RUN TIME variable tracks the time during which the DSP on the Pixie-16 module was “switched on” for data acquisition. It essentially counts the time from the command to start a data acquisition to the command to end it. However, it does not include the time spent for run start initialization, which, in some cases like synchronous run start among multiple modules, could be significant since modules might have to wait for a long time before the last module is ready to actually start data acquisition. Therefore, the RUN TIME is different from counting a wall clock which simply starts from one point and ends at another. Rather, RUN TIME counts the time during which the modules are actually taking data. The main use of RUN TIME is to compute channel event rate (total output counts of one channel / RUN TIME).

LIVE TIME

The LIVE TIME is counted in the FPGA independently for each channel and measures the time the channel is ready for acquisition. The LIVE TIME counter starts when the DSP finished all setup routines at the beginning of a run, omits the times the ADC signal is out of range, and ends when the DSP encounters an end run condition (e.g., host stop). It is thus the time during which triggers are counted and can cause recording of data, the best available measurement of the time the channel was active.

FASTPEAKS

The Pixie-16 counts the number of triggers in each channel in the Signal Processing FPGA. The trigger is the result of the fast filter response crossing the fast trigger threshold. The FASTPEAKS counter is cleared at the start of each run.

CHANEVENTS

The number of events processed by the DSP for each channel of a Pixie-16 module is called CHANEVENTS. It only counts the events that are actually recorded either into the list mode output data stream or the MCA spectrum. Therefore, it does not include those events that are recorded by the FPGA but are rejected by the DSP according to certain event acceptance criteria, e.g., energy cutoff threshold, etc. The CHANEVENTS counter is cleared at the start of each run.

6.6.2 Count Rates

Count rates are computed in the Pixie-16 C library as follows:

$$ICR = \frac{FASTPEAKS}{LIVETIME} \quad (6-4)$$

$$OCR = \frac{CHANEVENTS}{RUNTIME} \quad (6-5)$$

7 Appendix A – Coincidence Example

The parameter settings of the Pixie-16 are very flexible, but can be complex at first look. Therefore we here illustrate a basic coincidence setup as an example of how to set up a coincidence requirement.

Requirement:

Capture data only if two channels of a module see pulses with a coincidence window CW.

Setup and Tools:

- 2 detector or pulser signals connected to channel A and B of a Pixie-16
- (optional) Oscilloscope for probing signals on IO connector (Table 1-11)

Approach:

Each channel sends its fast trigger signal to the System FPGA using parameters *Fast Trigger Backplane Delay* and *Fast Trigger Backplane Length*. At the same time, its local pulse processing is delayed by *External Delay Length*, which acts like a longer cable between the detector and the Pixie-16 (except for the backplane and System FPGA trigger distribution.)

In the System FPGA, all channel’s fast trigger backplane signals are first masked with the Multiplicity Mask bit pattern that is specific for each channel. Then a coincidence test is applied using logic AND and arithmetic ADD operations. Finally, depending on control bits in Multiplicity Mask High, the output is send back to each channel.

Each channel, receiving the coincidence test result (the “chantrig” signal) from the System FPGA, creates a validation window of length *Channel Trigger Stretch*. This can be probed on output FO4. If validation is required (*CCSRA_CHANTRIG*), pulses are only accepted for processing if the delayed local trigger (FO0) occurs during this validation window. Acceptance during a run generates the signal on FO2.

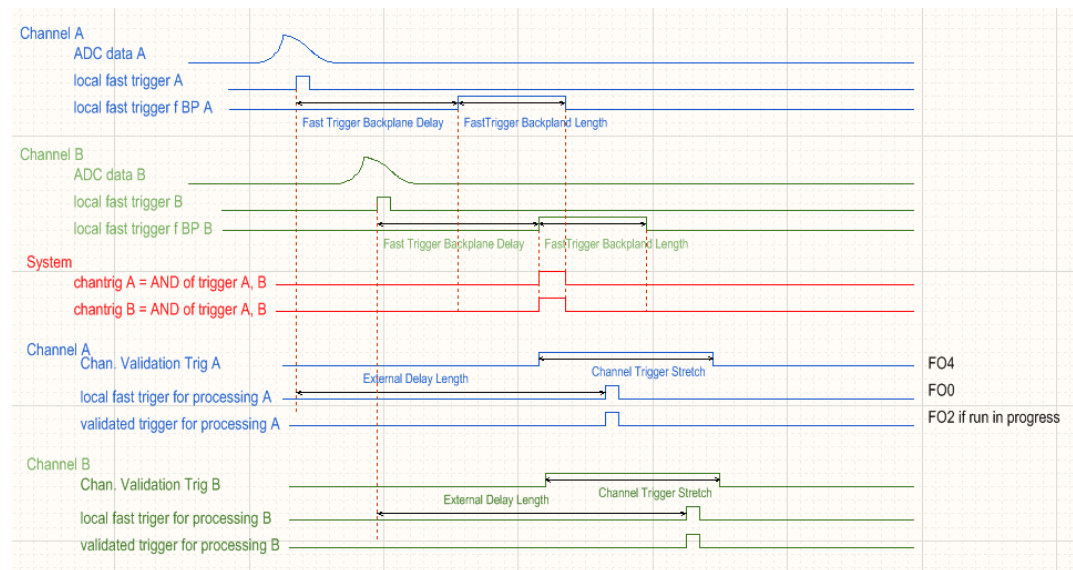

Figure 7-1: Illustration of channel validation by coincidence trigger between two channels.

Parameters for coincidence of 2 or more channels:

- *CCSRA_CHANTRIG* (bit 13) = 1 to require validation by the chantrig signal, which provides the coincidence result for each channel.
- *Multiplicity Mask Low* = 0x0000 FFFF to mask contribution from the right neighbor (upper 16 bits) and allow all channels from local module (lower 16 bits) and *Multiplicity Mask High* = 0x0080 0000 to mask contribution from the left neighbor (lower 16 bits) and the upper bits, per Table 3-7, selecting coincidence trigger and group 1 coincidence threshold 2 or more.

Multiplicity Parameters	Description	Value
Multiplicity Mask Low[15:0]	User defined 48-bit contribution mask [15:0] (masking fast triggers from the module itself)	FFFF
Multiplicity Mask Low[31:16]	User defined 48-bit contribution mask [31:16] (masking fast triggers from the module's right side neighbor)	0000
Multiplicity Mask High[15:0]	User defined 48-bit contribution mask [47:32] (masking fast triggers from the module's left side neighbor)	0000
Multiplicity Mask High[16]	Select either multiplicity trigger (=1) or coincidence trigger (=0) as the source of the channel validation trigger	0
Multiplicity Mask High[21:17]	5-bit threshold for this channel's multiplicity trigger	0000
Multiplicity Mask High[24:22]	3-bit threshold for this channel's 1 st group of 16-bit coincidence trigger (the module itself)	010
Multiplicity Mask High[27:25]	3-bit threshold for this channel's 2 nd group of 16-bit coincidence trigger (the module's right side neighbor)	000
Multiplicity Mask High[30:28]	3-bit threshold for this channel's 3 rd group of 16-bit coincidence trigger (the module's left side neighbor)	000
Multiplicity Mask High[31]	Select group trigger/external fast trigger (=1) or multiplicity/coincidence trigger (=0) as the source of the channel validation trigger	0

- *TrigConfig0* = 0x008n8000 to enable the output to the front panel IO connector (bit 15), choose channel n's signals for the output and output the OR of all chantrig signals on FO6.
- *Fast Trigger Backplane Delay* = 0 unless delays between channels have to be accommodated
- *Fast Trigger Backplane Length* = CW
This defines the range of overlap of trigger signals in the coincidence logic
- *Channel Trigger Stretch* = CW
This defines the length of the coincidence validation for the local trigger
- *External Delay Length* = CW
This ensures that the first channel to trigger still sees the coincidence result from the later channel which may be delayed by CW.

Adjusting CW delay parameters:

To adjust parameters for cable delays and pulse characteristics, we recommend copying each detector signal into 2 inputs, enabling only one channel to contribute to the coincidence logic, and probing the copied channel's triggers on the front panel connector. In other words,

- Connect the same signal A to channel e.g. 9 and 10 with equal cable length.
- Set *TrigConfig0* = 0x00898000 (probe channel 9),

- Temporarily set *Multiplicity Mask Low* = 0x0000 0400 (mask all but channel 10)
- Temporarily set *Multiplicity Mask High* = 0x0040 0000 (coincidence threshold 1 or more)

and verify that the validation created by channel 10 (FO4) is timed correctly to validate the delayed local trigger (FO0). The FO0 pulse should occur near the end of the FO4 window. If not, adjust the lengths and delays.

Repeat this for the other detector B using e.g. channels 11 and 12. Then, removing the copied inputs and changing the masks back to require 2 triggers from any channel, a pulse from detector A on channel 10 will validate a pulse from detector B on channel 12 within CW and vice versa – essentially the other detector takes the place of the copies channel if it occurs within CW.

Notes:

- There is great flexibility in adjusting delays and stretches individually for each channel, creating asymmetric coincidence results.
- If the External Delay Length is shorter than CW, the channel starting the coincidence may not be validated because its local trigger comes earlier than the validation started by the pulse from the later channel. (In this case the FO0 pulse would occur before FO4.) The later channel however would be validated.
- If the Channel Trigger Stretch is shorter than CW, the later channel may only issue its delayed local trigger when the validation window has already passed, and only the earlier channel would be validated. (In this case the FO0 pulse would occur after FO4.)
- For the additional use distributed triggers from the backplane, the following re-drawing of sections 3.3.11.5 and 3.3.11.6 (same coloring) may be useful

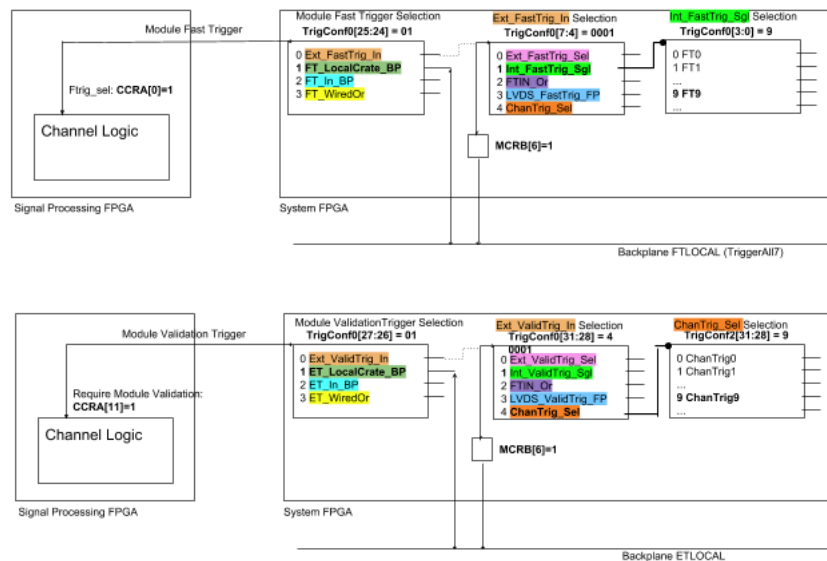

M0: TrgConf0 = 0x45xxx019, TrgConf2 = 0x90000000
 M1: TrgConf0 = 0x05xxx0xx, TrgConf2 = 0xx0000000